

Manual of Mainlaying Practice

2012 Edition

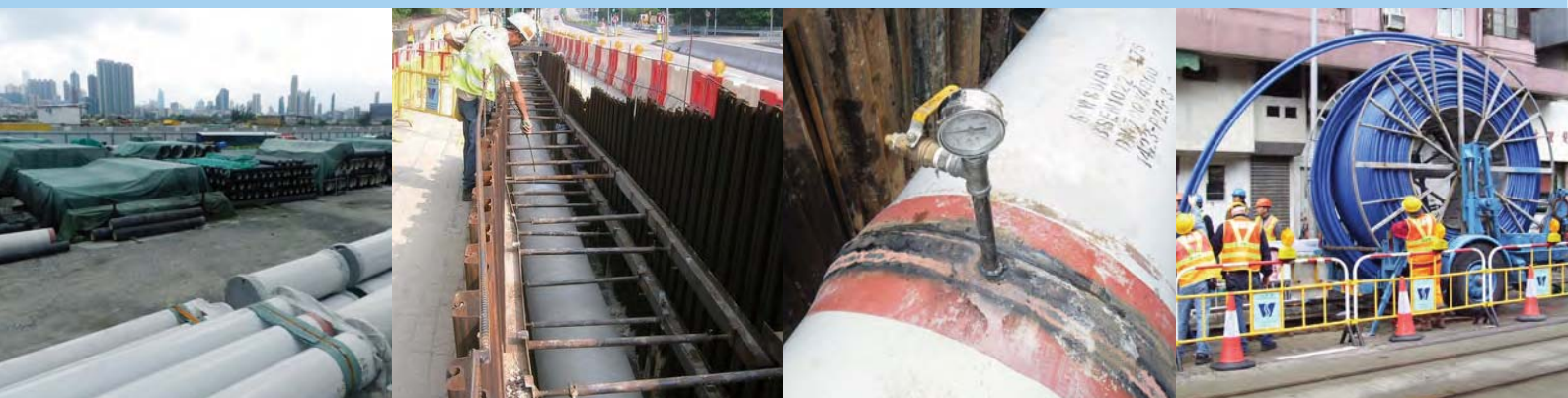

Water Supplies Department

The Government of the Hong Kong Special Administrative Region

[This page is intentionally left blank]

MANUAL

OF

MAINLAYING PRACTICE

(2012 Edition)



Water Supplies Department
The Government of the Hong Kong
Special Administrative Region

CONTENTS

Section		Page No.
1	DESIGN	1
1.1	Standard Size, Type and Class of Pipes	1
1.2	Design Criteria	2
1.3	Operational Requirements	5
2	MATERIALS	11
2.1	Specification	11
2.2	Steel Pipes and Fittings	11
2.3	Ductile Iron (DI) Pipes and Fittings	12
2.4	Polyethylene (PE) Pipes and Fittings	12
2.5	Galvanised Iron (GI) Pipes and Fittings	13
2.6	Stainless Steel Pipes and Fittings	13
2.7	Other Pipe Materials No Longer Used by WSD for New Mains	14
3	INSTALLATION	15
3.1	Preparation Work for Trench Excavation	15
3.2	Excavation in Trenches	15
3.3	Safety of Road Opening for Mainlaying Works	17
3.4	Cover to Mains	18
3.5	Laying Pipes	20
3.6	Thrust Blocks	21
3.7	Transverse Anchor Blocks	23
3.8	Nitrogen Gas Test for Steel Pipes	23
3.9	Backfilling	23
3.10	Hydrostatic Pressure Test	24
3.11	Cleaning and Sterilisation of Fresh Water Mains	25

Section		Page No.
3.12	Cathodic Protection of Water Mains	26
3.13	Service Connections and Integrating New and Existing Distribution System	31
3.14	Fire Hydrants	32
3.15	As-built Records of Water Mains	32
4	REPAIR, REHABILITATION, OPERATION AND MAINTENANCE OF WATER MAINS	34
4.1	Repairs to Mains and Submains	34
4.2	Leak Detection	35
4.3	Draining of Mains Through Washout Valves	35
4.4	Rehabilitation of Water Mains	35

List of Appendices

- 1.1 Guideline for Orderly Disposition of Utilities Services
- 1.2 Pressure Reducing Valve Chamber
- 1.3 Electromagnetic Flowmeter Chamber on Carriageway for Pipe Size DN300 or below
- 1.4 Transmitter Pit on Footpath
- 1.5 Arrangement for Buried Electromagnetic Flowmeter
- 1.6 Electromagnetic Flowmeter and Pressure Reducing Valve Combined Chamber
- 1.7 Electromagnetic Flowmeter, Pressure Reducing Valve and In-line Strainer Combined Chamber
- 1.8 Critical Pressure Point Pit on Footpath
- 1.9 Contact Point for Leak Noise Correlation
- 2.1 Special Joints for Steel Pipes
- 2.2 Connection of Two Steel Pipes using Ductile Iron Pipe
- 2.3 Connections for Ductile Iron Pipes
- 2.4 Connection of Galvanised Iron Pipe to Valve
- 2.5 Tee Connection from Asbestos Cement or Cast Iron Pipes
- 2.6 Repairs to Water Mains
- 2.7 Joints on Existing Cast Iron Water Mains
- 3.1 Restricted Zone for Utilities around Deep Sump Gullies
- 3.2 Record Form for Hydrostatic Pressure Test
- 3.3 Guidelines in Making Replacement Service Connections in R&R Works
- 3.4 Cathodic Protection System
- 3.5 Not Used
- 3.6 Not Used
- 3.7 Installation of Pedestal and Swan Neck Hydrants
- 3.8 Notification Form for Shallow Covered Water Mains
- 3.9 Mains Records Sign Conventions and Designations
- 4.1 Details of Arrangement for Flushing at Dead-end Mains adjacent to District Boundary Valve
- 4.2 Advantages and Disadvantages of Various Methods of Rehabilitation of Water mains
- 4.3 Schematic Arrangement for Connecting Pipe Rehabilitated by Close Fit Lining / Sliplining to Existing / New Pipe

List of Appendices

- 4.4 Schematic Arrangement for Connecting Pipe Rehabilitated by Cured-in-place Pipe (CIPP) Method to Existing / New Pipe
- 4.5 Schematic Arrangement for Installing Sealing System for External Fibre Reinforced Polymer (FRP) Layer Wrap
- 4.6 Repair of Damaged Pipe Rehabilitated by Cured-in-Place Pipe (CIPP) Method
- 4.7 Procedure for Repair of Pipe Rehabilitated by Internal Fibre Reinforced Polymer (FRP) Layer Lining
- 4.8 Procedure for Repair of Pipe Rehabilitated by External Fibre Reinforced Polymer (FRP) Layer Wrap
- 4.9 Procedure for Installation of Pre-fabricated Fitting on Pipe Rehabilitated by Internal Fibre Reinforced Polymer (FRP) Layer Lining
- 4.10 Procedure for Installation of Pre-fabricated Fitting on Pipe Rehabilitated by External Fibre Reinforced Polymer (FRP) Layer Wrap

SECTION 1 - DESIGN

1.1 Standard Size, Type and Class of Pipes

The types of pipe materials commonly used in new works for both fresh and salt water mains by WSD are as follows:

Pipe Size (nominal diameter in mm)	Type of Pipe Material
700 and above	<ul style="list-style-type: none"> ● Steel
200 to 600	<ul style="list-style-type: none"> ● Ductile Iron (DI) ● Steel
150	<ul style="list-style-type: none"> ● Buried Pipe: Blue Polyethylene (PE), steel, DI ● Exposed Pipe: Steel, DI
100 and below	<ul style="list-style-type: none"> ● Buried Pipe: Blue PE, DI ● Exposed Fresh Water Pipe: steel, DI ● Exposed Salt Water Pipe: Black PE
Service Connections	<ul style="list-style-type: none"> ● Buried Fresh Water Pipe: Blue PE ● Buried Salt Water Pipe: Blue PE ● Exposed Fresh Water Pipe: Stainless Steel, Corrugated Stainless Steel Tubes ● Exposed Salt Water Pipe: Black PE

Where other types of materials (such as stainless steel for exposed salt water pipes with nominal diameter 100 and below, stainless steel for exposed salt water service connections, etc.) are proposed in the new works, prior agreement should be sought from the relevant Chief Engineer/Region of WSD.

The size of water mains refers to the nominal diameter (abbreviated as DN) for pipes other than polyethylene pipes and to the nominal size (abbreviated as NS) for polyethylene pipes. The standard nominal diameters of pipes used by WSD, together with the equivalent nominal sizes of PE pipes (up to 315 mm) are listed below:

Nominal Diameter (in mm)	Equivalent Nominal Size of PE Pipe (in mm)	Nominal Diameter (in mm)	Equivalent Nominal Size of PE Pipe (in mm)
15	20	600	---
20	25	700	---
25	32	800	---
40	50	900	---
50	63	1000	---
80	90	1200	---
100	125	1400	---
150	180	1600	---
200	250	1800	---
250	315	2000	---
300	---	2200	---
400	---	2500	---
450	---		

The classes of pipe materials currently used in new works by WSD are summarised below:

Pipe Material	Class
Steel	<ul style="list-style-type: none"> ● Tensile strength of steel not less than 430 N/mm²
DI	<ul style="list-style-type: none"> ● Pipe: Class K9 ● Fitting without branches: Class K12 ● Fitting with branches: Class K12 (or higher when required)
PE	<ul style="list-style-type: none"> ● PE100 for pipe from NS20 to NS315
Lined GI	<ul style="list-style-type: none"> ● Pipe: medium series to BS EN 10255 ● Polyethylene lining: conform to JWWA K132 ● Polyvinyl chloride lining: conform to JWWA K116
Stainless Steel	<ul style="list-style-type: none"> ● Pipe: steel number 1.4404 to BS EN 10088-1 ● Fitting: steel number 1.4401 to BS EN 10088-1

1.2 Design Criteria

For a Pipe in General

1.2.1 Pipe Size

The size of a water main is determined by the flow it has to carry in accordance with **Departmental Instruction (DI) No. 1309 “Design Criteria”**. Generally speaking, the pipeline should be of sufficient size such that the maximum flow velocity under peak flow for both pumping mains and distribution mains should be less than 3 m/s. In case of distribution mains

installed with fire hydrants, the size of the water main may be governed by the flow to meet fire fighting purpose as required by the Fire Services Department.

Designers should, as far as practicable, avoid using the same pipe size and material for both fresh and flushing water systems at the same location in order to minimise the difficulty in identifying the fresh and flushing water mains. In addition, designers should avoid oversize of water mains which may result in water quality problems and should allow for provision of adequate flushing points of sufficient sizes to handle water quality issues.

1.2.2 Pipe Route

The routing of pipes calls for careful consideration of many factors including hydraulics, ease of operation and maintenance, disruption to surroundings, risks of pipe failures and flooding caused to adjacent properties, availability of measures to mitigate the risks, difficulty of making connections, etc. In practice, pipe routings are often dictated by the availability of underground space, especially for pipes to be laid in urban areas. It may be preferable to lay pipes within the carriageway area due to congested utilities in the footpath area.

Whenever possible, pipes should be laid in road reserves. Designers should apply, as far as practicable, the “good practices” as recommended in “**Guideline for Orderly Disposition of Utilities Services**” issued by the Joint Utility Policy Group, which is attached at **Appendix 1.1**. Where pipes have to be laid outside road reserves, the land status of the pipe route should be ascertained. Land reservation, wayleave or consent of land owners must be obtained. Except as a temporary measure, pipes should not be laid under the site of proposed buildings/structures.

The vertical alignment of pipelines should be designed to comply with the requirements of covers to pipes as described in Section 3.4.

Water mains should be routed as far as possible away from the influence zone (which may be taken as a strip alongside and close to the crest) of a slope, within which leakage of water mains could affect the stability of the slope. When water mains have to be laid in a buried condition within the influence zone, the requirements stipulated in “**Geotechnical Manual for Slopes**” published by Geotechnical Engineering Office and “**Code of Practice on Monitoring and Maintenance of Water Carrying Services Affecting Slopes**” published by the then Environment, Transport and Works Bureau should be complied with. Measures to safeguard against the effect of leakage include the provision of leakage collection systems (as per **Standard Drawing WSD 1.20**). Laying water mains in an exposed manner or laying water main along a concrete trough within the influence zone is another alternative if it is

practicable and aesthetically acceptable to parties concerned.

In cases where water mains are unavoidably required to be laid along or across critical traffic routes (e.g. red/pink routes) or busy road junctions, the design should be enhanced to minimise the chance of pipe failure and/or to minimise the consequence of pipe failure. The water mains should also be suitably designed to facilitate future operation and maintenance.

1.2.3 Choice of Pipe Installation Method

The choice of installation method for pipes should take due consideration of the future maintenance requirements. For those cases where maintenance is virtually impossible or takes a very long period of time (e.g. pipes installed by horizontal directional drilling), supply redundancy should be allowed in the network design to allow for isolation of the said mains without affecting the supply.

For a Pipe Network

1.2.4 Establishment of District Meter Areas

A supply zone of a service reservoir can be sub-divided into district meter areas (DMA), each with a hydraulically discrete boundary and of manageable size. These areas enable continuous leakage monitoring and facilitate prioritisation of leak detection work in an efficient and beneficial way. Normally, a DMA is formed by installing one or more flowmeter(s) and several cut-line valves and/or district boundary valves along the DMA boundary.

During the design stage of a new mainlaying project, the Water Loss Management Section of Development (1) Division should be consulted on the requirements for provision of leak detection facilities and any additional valves. In particular, details of any mainlaying works which may affect the operation or even the integrity of existing DMAs (e.g. due to changes in the existing cut-line valves, district boundary valves and/or the supply network) should be provided in order to enable the Water Loss Management Section to determine the need for existing DMA facilities to be modified/replaced or additional facilities to be provided.

1.2.5 Establishment of Pressure Management Areas

When pressure management is implemented within a DMA to control the excessive pressure in the distribution system, the DMA is called a Pressure Management Area (PMA). Normally, a pressure reducing valve will be

installed at the entry point next to the flowmeter inside a combined chamber in a by-pass arrangement to the main water main.

Similar to DMAs, details of any mainlaying works which may affect the operation or even integrity of existing PMAs should be provided to the Water Loss Management Section of Development (1) Division for comments during the design stage of a new mainlaying project.

1.3 Operational Requirements

1.3.1 Designers should, in consultation with the relevant Regional Office, Development (1) Division and other divisions/units of WSD as appropriate, provide sufficient valves along the proposed water mains to suit operational and maintenance requirements. Different types of valves commonly used by WSD in the water supply network are given below for reference. Flowmeters, multi-purpose inspection chambers, critical pressure points and contact points for leak noise correlation, which are used by WSD for district metering, pressure management or leak detection, are also described briefly below.

1.3.2 Sectional Valves

Sectional valves are gate (or sluice) valves used to isolate sections of a pipeline in an emergency or for maintenance and repair. They should be installed along a pipeline at a spacing from 300 m to 800 m. It should be noted that gate valves are suitable for isolation of a pipeline in either “fully open” or “fully close” positions, but not for frequent open/close operation and flow regulation. Whenever possible, valves should not be positioned at road junctions or in heavily trafficked areas to avoid disruption to traffic during the construction and operation in valve chambers.

Valves of DN100 to DN300 should be vertical valves. See **Standard Drawing WSD 1.10** for details of the valve chambers. Valves of DN400 or above should be horizontal valves. Vertical valves of diameter DN400 or above should be used only if there is no space for construction of horizontal valve chamber. See **Standard Drawings WSD 1.11 and 1.12** for details of horizontal valve chambers and **WSD 1.46 and 1.47** for details of vertical valve chambers.

All valves should be ordered with nominal pressure rating PN16 unless in special circumstances where higher pressure rating is required. As a normal practice, valves of DN600 or above should be provided with an external by-pass arrangement to link up the upstream and downstream sides of the valves (see **Standard Drawing WSD 1.11** and **Appendix 1.3 of Civil Engineering Design Manual Volume II**). These valves should not be fitted

with a built-in by-pass. In some circumstances, a smaller size closed valve subject to a high unbalanced head may also be provided with an external by-pass arrangement.

1.3.3 Cut-line Valves

Cut-line valves are gate valves for separating two service reservoir supply zones, and are normally kept closed. The cut-line valves for fresh water supply systems are assigned valve reference numbers with a prefix “C” in accordance with **Operations Branch Instruction No. 02/2005 (Distribution) “Valve Reference Numbering System and Valve Reference Number Plate”** (or its latest revision issued by Operations Branch).

1.3.4 District Boundary Valves

District boundary valves (DBVs) are gate valves installed at the boundary of a DMA/PMA for isolation of the DMA/PMA within a service reservoir supply zone. DBVs for fresh water supply systems are assigned valve reference numbers with a prefix “M” in accordance with **Operations Branch Instruction No. 02/2005 (Distribution) “Valve Reference Numbering System and Valve Reference Number Plate”** (or its latest revision issued by Operations Branch). Similar to the cut-line valves, DBVs are normally kept closed.

1.3.5 Washout Valves

Washout valves (WOVs), formed by gate valves, are necessary to allow sediment to be flushed out and to enable the pipeline to be drained for maintenance and repair work. WOVs are assigned valve reference numbers with a prefix “S” which stands for “Scour” in accordance with **Operations Branch Instruction No. 02/2005 (Distribution) “Valve Reference Numbering System and Valve Reference Number Plate”** (or its latest revision issued by Operations Branch). At least one washout valve should be provided at the lowest point between two sectional valves on the pipeline and at the dead end of a pipeline. Double valves should be provided to washouts for trunk mains and primary distribution mains to suit operation needs. The upstream valve should be opened while the downstream valve should be closed so that the washout pipe on the upstream side of the downstream valve is fully charged with water.

Care should be taken to position the discharge points of washout pipes to avoid water in nullah/stream course seeping through the washout pipes into the water mains. If there are no suitable existing watercourse or drainage systems near to the proposed washout valve (e.g. the main is deeper than the neighbouring drains), washout pump pits as per **Standard Drawing WSD 1.13** should be

provided to facilitate pumping of the discharge for disposal.

1.3.6 Butterfly Valves

Butterfly valves are usually lighter, cheaper, smaller and easier to operate than gate valves. However, as they do not give a positive seal as compared with gate valves, they should not be used as washout valves. Similarly, as they cannot be completely opened to allow the passage for pigging and swabbing operations, they should not be used as sectional valves. Butterfly valves are normally used as control valves in treatment works and the inlets/outlets of reservoirs.

1.3.7 Air (Release) Valves

Air valves are necessary in a pressurised pipeline to release accumulated air or to allow air to enter should a partial vacuum occur. They should be located at high points on the pipeline or at locations where there is a peak or, in some cases, a change to a flatter gradient after a long rise. They are automatic in operation.

There are two types of valves, namely large orifice air valves and small orifice (single) air valves. The former is used wherever large volumes of air must be expelled or admitted rapidly at relatively small differential pressures during filling and emptying of sections of a pipeline. The latter is used for bleeding off small volumes of air released from water whilst the pipeline is in service and under pressure. Double air valves combining the above features are available. See **Standard Drawings WSD 1.8 and 1.9** for typical arrangement of single and double air valves.

1.3.8 Non-return (or Check) Valves

Non-return valves are used to enable flow in one direction (forward) in a pipeline and stop reverse flow. They should be installed on pumping mains at the pumping outlets to prevent damage to the pump impellers from surges when the pumps cut out. They should also be installed at the reservoir inlet in case of bottom entry, in order to prevent emptying of the reservoir in case a pipe burst does occur along the inlet main.

1.3.9 Pressure Reducing Valves

Pressure reducing valves (PRVs) are used to maintain a preset, reduced, generally constant outlet (downstream) pressure for a range of flow rates and inlet (upstream) pressure in the distribution system. They are usually installed in a by-pass arrangement to the main water mains and help stabilise water pressures in the distribution system, reduce water loss and frequency of

leaks and bursts in the distribution system and extend the life of water mains. The typical arrangement of a PRV chamber is shown in **Appendix 1.2**. In case of large fluctuations (e.g. more than 10 m) in the pressures at the critical pressure points within a PMA, the outlet pressure of the PRV may be adjusted by using a PRV controller in either time modulation or flow modulation mode to optimise the pressure reduction.

1.3.10 Flowmeters

A flowmeter is usually installed at the delivery main from a pumping station, at the inlet and outlet mains of a service reservoir or within treatment works to measure the quantity of water flow for a supply zone. For a DMA/PMA, a flowmeter is installed at the inlet of the DMA/PMA to monitor continuously the quantity of water flowing into or out of the DMA/PMA. It is normally installed in a by-pass arrangement in the main water main at the footpath or verge area. The valve on the main water main between the by-pass valves should be kept closed at all times and as such, it is classified as a district boundary valve. The flowmeter for a DMA/PMA is typically an electromagnetic flowmeter though mechanical flowmeters have been used in the past. Details of the flowmeter chambers are shown in **Standard Drawings WSD 1.41** and **1.42** for electromagnetic flowmeters for pipe sizes DN300 or below and DN400 or above respectively and **WSD 1.33** for mechanical flowmeters.

If the flowmeter for a DMA/PMA is installed in the carriageway or buried without being housed in a chamber, a transmitter pit should be constructed in the footpath to accommodate the associated flow transmitter and data logger linking to the flowmeter by appropriate means. Drawings showing the typical details of flowmeter chambers on carriageway and the associated transmitter pits, buried flowmeters, and flowmeter and pressure reducing valve combined chamber are listed below.

Appendix	Drawing Title
1.3	Electromagnetic Flowmeter Chamber on Carriageway for Pipe Size DN300 or below <i>(for other electromagnetic flowmeter chambers, refer to Standard Drawings WSD 1.41 and 1.42)</i>
1.4	Transmitter Pit on Footpath
1.5	Arrangement for Buried Electromagnetic Flowmeter
1.6	Electromagnetic Flowmeter and Pressure Reducing Valve Combined Chamber
1.7	Electromagnetic Flowmeter, Pressure Reducing Valve and In-line Strainer Combined Chamber

Buried flowmeters should only be adopted when there is site constraint such as insufficient underground space for construction of a chamber.

As a special type of flowmeter, waste detection meters are used to record the minimum night flows for waste detection areas which are gradually replaced by DMAs/PMA. Details of waste detection meter chambers are shown in **Standard Drawing WSD 1.32**. In addition, portable flowmeters are also used by WSD for flow measurements. Details of portable flowmeter chambers are shown in **Standard Drawings WSD 1.25 and 1.27**.

Designers should note that:

- A flowmeter should be located at a position such that it is always in full bore operation.
- Flowmeter pits should be easily accessible and should not be located under carriageway as far as practicable.
- Flowmeter pits should be properly drained to prevent flooding.

It should be noted that for pipelines with flowmeters, straight lengths of at least 10 times and 5 times the pipe diameter, absolutely free of bends or other fitting and specials, upstream and downstream of the flowmeter respectively are essential for reasonably accurate measurements. For electromagnetic flowmeters, such requirement can be less stringent. Designers should refer to relevant catalogue to determine the required straight length recommended by the manufacturer.

1.3.11 Multi-purpose Inspection Chambers

Multi-purpose inspection chambers (MPIC) should be provided for flow measurement and leak detection, and where necessary, replace double air valve chambers and inspection manholes. During the design stage of a new mainlaying project, the Water Loss Management Section of Development (1) Division should be consulted on the requirements for provision of multi-purpose chambers. As a general guide, a spacing of 700 m is recommended between the inspection chambers; whilst the exact spacing should be determined on a case-by-case basis depending on the fittings along the alignment. See **Standard Drawings WSD 1.48, 1.49, 1.50, 1.51, 1.52 and 1.53** for various types of multi-purpose chambers.

1.3.12 Critical Pressure Points

Critical pressure points (CPP) are usually located at the highest altitude and/or the most remote position within a DMA/PMA where the normal hydraulic pressure in the water supply system is the lowest. A tapping point at the CPP

is provided for connection with a portable pressure meter. Typical details of a CPP pit on footpath are shown in **Appendix 1.8**.

1.3.13 Contact Points for Leak Noise Correlation

Contact points for leak noise correlation should be provided for long lengths of water mains, particularly trunk mains where fittings (such as isolation valves, air valves, hydrants, etc.) are not available to serve as contact points for leak noise correlation. During the design stage of a new mainlaying project, the Water Loss Management Section of Development (1) Division should be consulted on the requirements for provision of contact points for leak noise correlation. See **Appendix 1.9** for details of the contact points.

SECTION 2 - MATERIALS

2.1 Specification

WSD has fully adopted the “Supply and Lay” arrangement for provision of all mainlaying materials. Pipe materials such as pipes, fittings (including valves), hydrants, chamber covers, etc. should normally be supplied by the waterworks contractor.

The current specification for pipe materials adopted by WSD is detailed in the Model Tender Documents and can be downloaded from the Design Division’s intranet homepage.

Model specifications for flowmeters, pressure reducing valves and controllers, in-line strainers, pressure gauges, data loggers, noise loggers and other related accessories are available from the Water Loss Management Section of Development (1) Division on request.

2.2 Steel Pipes and Fittings

During the design stage for a mainlaying project for steel pipelines, it is not always possible to design the precise locations of hydrants, washouts, inspection tees or bends, particularly at locations with congested utilities, to allow specials to be ordered to suit the position of sockets and spigots of adjacent lengths. Therefore, in many cases specials for steel pipeline projects must be fabricated either on or off site.

Common steel pipes and specials are listed below for reference:

- (a) Full length (8m) pipe with spigot and socket end (DN700 or above);
- (b) Full length pipe with flange end (DN150 to DN600 inclusive);
- (c) Half (4m) and quarter (2m) length pipes with spigot and socket / flange ends;
- (d) Full length, plain end, truly circular pipes of the main diameters and of diameters required for hydrant, washout, branch, and inspection tees from which bends and tees can be fabricated;
- (e) Tapers;
- (f) Collars;
- (g) Slip-on type couplings and flange adaptors;
- (h) Expansion joints; and
- (i) Blank flanges and puddle flanges.

See **Standard Drawing WSD 1.21** for details of the welded spigot and socket

joints and collars, **Appendix 2.1** for special joints for steel pipes and **Appendix 2.2** for connection of two steel pipes using DI pipe.

2.3 Ductile Iron (DI) Pipes and Fittings

DI pipes and fittings are normally used for pipes with sizes between DN100 and DN600. The class of DI pipes normally used is K9 to a pressure rating of 16 bar (gauge), with push-in flexible joints or mechanical joints. The pipe barrel of new DI pipes should be provided with an epoxy coat on top of a cement mortar lining as the internal protection to DI pipes.

For joining a DI pipe to a gate valve, a DI flange adaptor is the preferred fitting to be used in new works while a ductile iron collar used with a flange spigot piece is an acceptable alternative for existing DI pipelines. See **Appendix 2.3** for details.

The external diameters for pipes up to and including DN300 are all manufactured to tight tolerances throughout the barrel and any cut piece can be joined with a DI collar. However for pipes DN400 and above, some special pipes with tight tolerance on outside diameter must be ordered for cutting and jointing purposes.

For connections between DI pipes and polyethylene pipes, flange spigot piece or flange socket piece and a stub flange will be used. For connections between DI pipes and asbestos cement or cast iron pipes, DI change collars or mechanical joints will be used. See **Appendix 2.3** for details.

2.4 Polyethylene (PE) Pipes and Fittings

PE pipes are normally used for pipes with nominal sizes between NS20 and NS180. They should be made of PE100 material which has a minimum required strength of 10 MPa. PE pipes for use below ground should have a Standard Dimension Ratio (SDR) of 11 and have nominal pressure rating of 16 bar. PE pipes for use above ground should have a SDR of 9 with a nominal pressure rating of 20 bar.

Common PE pipes and fittings are listed below for reference:

- (a) Straight pipes and coiled pipes;
- (b) Electrofusion fittings (e.g. coupler, saddle, elbow, tee, reducer, etc.);

- (c) Mechanical joint fittings;
- (d) Compression joint fittings; and
- (e) Spigot fittings (e.g. fabricated bend, moulded bend, fabricated tee, moulded tee, stub flange, long spigot reducer, etc.).

Blue PE pipes and fittings are intended to be used below ground only. This type of PE pipe when exposed under prolonged sunlight will deteriorate in strength and therefore is not suitable for use in above ground condition. Black PE pipes and fittings are used for above ground salt water supply only.

PE pipes are not susceptible to corrosion and are relatively inert to chemical attacks except for some strong acids, detergents and hydrocarbons. They are relatively easy to handle and are cost competitive. However, fusion welding of PE pipes demands relatively high labour skill and good workmanship.

Jointing of PE pipes to steel pipes and DI pipes is shown in **Appendices 2.1** and **2.3**, whereas jointing of PE pipes to valves is shown in **Standard Drawing WSD 1.45**.

2.5 Galvanised Iron (GI) Pipes and Fittings

GI pipes should be ordered to be supplied in 5.5 m length with either polyethylene or polyvinyl chloride lining. They are connected by screwed joints. GI pipes should not be used in new works but lined GI pipes are allowed for use in repair. GI pipes, no matter lined or unlined, should never be used for salt water. For connection of GI pipes to valves, see **Appendix 2.4**.

2.6 Stainless Steel Pipes, Fittings and Corrugated Stainless Steel Tubes

Stainless steel pipes, fittings and corrugated stainless steel tubes are normally used for above ground fresh water service connections only. Stainless steel types 1.4404 (also known as grade 316L) and 1.4401 (also known as grade 316) should be used for stainless steel pipes/corrugated stainless steel tubes and fittings respectively. Jointing of stainless steel service connection pipes to underground PE pipes for fresh water mains is shown in **Standard Drawing WSD 1.44**.

2.7 Other Pipe Materials No Longer Used by WSD for New Mains

(a) Asbestos Cement (AC) Pipes

Use of AC pipes for both new works and maintenance works has been discontinued by WSD.

The class of AC pipe which has already been laid depends on the maximum working pressure as indicated below:

- Class 20: if maximum working pressure do not exceed 100 m head
- Class 25: if maximum working pressure exceeds 100 m head but less than 127 m head

For connecting DI pipes to AC pipes or making tee connections from AC pipes, part of the AC pipe may have to be replaced by DI pipes (see **Appendices 2.3 and 2.5**). For maintenance purpose, damaged AC pipes should be replaced by DI pipes (see **Appendix 2.6**) and a full length of AC pipe should be replaced instead of just the damaged portion to avoid cutting on AC pipes.

(b) Unplasticised Polyvinyl Chloride (UPVC) Pipes

Use of UPVC pipes for new works has been discontinued by WSD. The class of UPVC pipe normally used is Class D (12 bar - 20°C). For details of repairing damaged UPVC main, see **Appendix 2.6**.

(c) Cast Iron (CI) Pipes

Use of CI pipes for both new works and maintenance works has been discontinued by WSD. For connecting DI pipes to CI pipes, see **Appendix 2.3** and for providing tee connections from existing CI pipes, see **Appendix 2.5**. For joints on existing cast iron water mains, see **Appendix 2.7**. Existing CI pipes should be repaired using DI pipes as shown in **Appendix 2.6**.

(d) PE Pipes made of PE80 material

In the past, PE pipes with sizes ranging from NS20 and NS63 made of PE80 material were adopted by WSD. Having regard to the availability of PE80 material in the market in recent years, small sized PE pipes made of PE80 material are no longer used for new mains.

The methods for installing valves along PE80 pipe, making tee connection from other mains to PE80 pipe and repair of PE80 pipe are practically the same as those for PE pipes made of PE100 material.

SECTION 3 - INSTALLATION

3.1 Preparation Work for Trench Excavation

Some important preparation work before commencement of trench excavation is given below:

- (i) Prior to the commencement of excavation, the existence of utilities should be checked with their locations surveyed if possible. Trial pits may have to be excavated at suitable locations and non-destructive utility surveys carried out to ascertain the alignments and depths of the utilities.
- (ii) When trench excavation is to be carried out along existing public roads and unallocated government land, excavation permits should be obtained from Highways Department (HyD) and Lands Department respectively.
- (iii) Trench excavation usually affects existing road traffic and is therefore often carried out in sections. Relevant authorities such as Traffic Police, Transport Department (TD), HyD, District Offices, etc. should be consulted on the temporary traffic arrangement for carrying out the trench excavation works. For some special cases which can attract public attention, consent from District Councils may also be required.
- (iv) Adequate arrangement such as temporary decking across open trenches should be made for providing uninterrupted pedestrian access to all premises affected by the trench excavation works.

3.2 Excavation in Trenches

The following guidelines should be followed in carrying out trench excavation:

- (i) Excavation should be carried out by hand tools when working adjacent to utilities that are known, proven or suspected to exist. The requirements of the following codes of practice published by the Electrical and Mechanical Services Department should be complied with, when working near electricity supply lines and gas pipes:
 - **Code of Practice on Working near Electricity Supply Lines** (see http://www.emsd.gov.hk/emsd/e_download/pps/pub/electricity_publicop/ESLPR_COP_Full_Version_English.pdf)
 - **Code of Practice on Avoiding Danger from Gas Pipes** (see

[http://www.emsd.gov.hk/emsd/e_download/pps/gas/cop_gas_pipes\(english\).pdf](http://www.emsd.gov.hk/emsd/e_download/pps/gas/cop_gas_pipes(english).pdf)

- (ii) Trenches excavated on or above a slope may provide a location where infiltration of water into the slope can eventually lead to slope instability and trench-related slope failures. To provide a good practice of shoring support and drainage measures for trench excavations including those adjacent to slopes, the requirements in the "**Guide to Trench Excavations (Shoring Support and Drainage Measures)**" (see https://www.hyd.gov.hk/en/publications_and_publicity/publications/technical_document/guide_to_trench_excavations/index.html) published jointly by the Highways Department and the Civil Engineering and Development Department should be complied with.
- (iii) The sides of all trenches should be effectively supported to prevent collapse. Adequate trench support should be provided for excavation exceeding 1.2 m deep.
- (iv) Trenches should be no wider than necessary for the efficient laying and jointing of the pipes.
- (v) The bottom of the trench should be reasonably levelled from side to side, and hand-trimmed to form a uniform bed for supporting the pipe evenly along its whole length, and where surrounded or haunched with concrete to form a firm foundation for the concrete. At joints, recesses should be excavated on the sides and at the bottom of the trench.
- (vi) The bottom of the trench or foundation for pipe bedding and haunching should be protected from damage or deterioration by weather or any other causes.
- (vii) For trenches cut through wet soil or rock, the excavation should be carried out to a depth of 100 mm below the level of the bottom of the pipe to allow for 100 mm of sand/granular materials/other appropriate bedding material or concrete haunching.
- (viii) When pipelines are to be laid across carriageways where road traffic has to be maintained, the works should be carried out in sections and each section should not be longer than the width of a traffic lane. The first section should be backfilled, reinstated and opened to traffic before work commences on subsequent sections. Backfilling and reinstatement should be carried out immediately following the pipe laying in any section and should be completed with the minimum disruption to traffic. Sufficient steel plates should be provided for covering up the open trench in case of emergency.

- (ix) Special attention should be paid to the trench openings on carriageway, which have to be decked over temporarily by steel plates:
- For trench openings on high speed roads, red routes, pink routes and bus corridors that are to be covered with steel plates, before placing the steel plates into their positions, the trench openings should be temporarily packed with suitable materials to provide a firm support to the plates as far as practicable.
 - In addition to the normal inspections conducted on a routine basis, after each spell of heavy rainfall, visual inspections should be carried out on all trenches covered with steel plates to ensure that all the steel plates are securely in place. If situation warrants, the steel plates should be lifted up for more detailed inspections.
 - When applying temporary decking over a trench opening on the carriageway, the details as illustrated on **HyD's Standard Drawings H6135 and H6136** (or **H6162** if so stipulated by TD and Traffic Police) should be strictly followed.
 - All shoring supports should be properly designed and erected. To prevent loss of soil behind the shoring and thus weakening the shoring support, all voids behind the shoring, if any, should be properly filled with suitable materials. Attempts on early removal of the shoring supports to facilitate pipe laying or backfilling should be prohibited.
 - Spot welding should be applied to adjacent steel plates on carriageways to prevent dislocation of individual steel plates and minimise the generation of noise. For heavily trafficked routes, high speed roads or steep roads, full length welding should be applied to adjacent steel plates as far as practicable.
 - Placing steel plates at a skew position to the traffic flow direction should be avoided as far as practicable. If unavoidable, frequent inspections on the steel plates should be conducted and any abnormalities identified should be immediately rectified.

3.3 Safety of Road Opening for Mainlaying Works

Engineers and inspectors in charge of any mainlaying works by direct labour must ensure that the requirements in the “**Code of Practice for the Lighting, Signing and Guarding of Road Works**” published by HyD are observed.

Where the works is carried out by the Contractor, engineers and inspectors should ensure that the Contractor complies with the code of practice mentioned above even though the responsibility for observing the code of practice rests with the Contractor.

Engineers and inspectors should also ensure that adequate arrangements are made for access to all premises, for uninterrupted movement of pedestrians including the provision of footbridges over open trenches at regular intervals; and for the effective support of the sides of trenches to ensure safety of the public and labourers. Barricades provided adjacent to an excavated trench should be of sufficient strength to prevent falling of any person into the trench.

It should be borne in mind that the road opening performance is being continuously monitored by HyD and every effort should be made to ensure compliance with the Conditions of Excavation Permit.

3.4 Cover to Mains

Normally, pipes to be laid outside “kerb zone” as defined in **HyD’s Standard Drawing Nos. H6168, H6169 and H6170 “Minimum Depth Requirement for Underground Services”** should be laid with the minimum cover as shown below:

Existing road		Temporary haul road/road under construction	Cycle track/footpath /open area/verge
where no reconstruction is anticipated	scheduled for reconstruction	700 mm measured from the existing ground level or future site formation level, whichever is the lower	600 mm measured from the existing ground level
1 m measured from the road surface	1 m measured from the existing road surface or the future road surface, whichever is lower		
Note: Haul road open to public should be considered as existing road.			

Mains to be laid in cycle tracks/footpaths/open areas/verges where there is a possibility of vehicles parking or running on them should be provided with the same cover as those under carriageways. In particular, mains beneath footpaths in industrial areas are to be laid with the same cover as those under carriageways. In this connection, industrial areas are taken as those areas zoned as “INDUSTRIAL” in the Outline Zoning Plan. Consideration should be given to incorporate such requirement in areas which have been proposed or

may be designated as industrial area or are likely to be used for industrial purposes.

Any proposal to lay a main on filling exceeding 1.5 m in depth must be carefully considered with regard to the degree of consolidation and the risk of subsequent movement. Moreover, filling over a main in excess of 2.1 m above the crown of the pipe, except where deeper laying for short lengths is necessary to avoid obstructions, should not be accepted without careful consideration. In either case, the proposal should be referred to the Chief Engineer/Region for approval.

The above general guidelines do not preclude analysis to be carried out in special cases. Special design considerations should be made for pipes exceeding 1200 mm diameter.

If it is necessary to lay a main with cover less than the specified minimum value, consideration must be given to the amount of cover needed for valves, and to the necessity for special protective measures. Only with the approval of the Chief Engineer/Region should water mains with shallow cover with adequate protection be laid to suit the site conditions. In order to minimise the number of water mains damaged by road opening contractors, proper records on these shallow covered water mains (i.e. those mains with covers less than 450 mm under footway and 900 mm under carriageway as stipulated in the Conditions of Excavation Permit promulgated by HyD) in the Digital Mapping System should be made for future reference.

To facilitate the keeping of a central register of all shallow covered water mains, all new shallow covered water mains laid, existing unrecorded shallow covered water mains discovered, or existing recorded shallow covered water mains altered should be reported to the Drawing Office as detailed in Section 3.14. In fact, reporting of anomalies about shallow covered mains is part of the practice of reporting differences between details shown in the Digital Mapping System and those found on site to the Drawing Office for rectification.

Special cover requirements are stipulated in **HyD's Standard Drawing Nos. H 6168, H 6169 and H6170**, especially for water mains running along kerb zones. Waiver for shallow covered mains should be obtained from HyD before seeking the approval of the relevant Chief Engineer/Region of WSD, if mains not meeting cover requirements have to be laid in carriageway, footpaths and cycle tracks which are under the jurisdiction of HyD.

Procedures regarding the laying of small diameter mains in footpaths and back lanes are covered by **DI No. 929 "Laying of Connections and Inside Service/Fire Service on Government Land"**.

3.5 Laying Pipes

A number of general directions for pipe laying are as follows:

- (i) Before a pipe is lowered into the trench, it should be inspected for damage and any unsatisfactory lengths must be rejected for use. The inside of each pipe length should, if necessary, be washed with clean water and, where particularly dirty, brushed out with a strong solution of bleaching powder. Precautions should be taken to prevent further contamination.
- (ii) The serviceable life of ferrous metal pipes or steel pipes, particularly those used in the salt water distribution system, depends mainly on the internal lining. Before laying, it is most important to ensure that the lining and external protection of the pipes, especially for steel pipe fittings fabricated by the Contractor, is sound and that all damaged spots are repaired. After laying, all joints must be made good and any damage to the external protection repaired or protected by anticorrosion tapes prior to backfilling.
- (iii) Flow disturbance will cause inaccurate readings of flowmeters. If any repair is made to the internal lining of a pipe in the vicinity of an installed flowmeter, the repaired lining should be made to the same thickness as the original and that the finished surface and profile are free from any irregularities.
- (iv) External protection to steel flange joints, slip-on type couplings and flange adaptors should be provided using petroleum type anticorrosion tapes with primer and mastic filler. External protection to buried steel pipe body should be provided with epoxy or bituminous anticorrosion tapes as appropriate.
- (v) Whenever possible, full length pipes should be used instead of cut length pipes to reduce the number of joints in the pipeline. When cut length is required such as at position of bends or tees, it is preferable to check whether ready-to-use cut length pipes can be used instead of cutting from a full length pipe.
- (vi) Pipes should never be pushed off the bank or allowed to fall into the trench.
- (vii) When pipelaying is not in progress, the open ends of installed pipes should be temporarily closed by wooden stoppers or appropriate means to prevent entrance of dirt and trench water.

- (viii) Pipe lengths should never be deflected in the joint to any greater degree than recommended by the manufacturer.
- (ix) Pipe should have adequate support along their whole length or should be bedded, haunched or surrounded with concrete as per **Standard Drawing WSD 1.1**. The use of timber or other means to save forming socket holes must not be permitted. All objects on or in the surface on which the pipe is to be laid which may cause damage to the pipe should be removed.
- (x) Pipelaying should follow closely upon the progress of trench excavation.
- (xi) All necessary precautions should be taken to prevent floatation of pipes.
- (xii) For pipelaying near deep sump gullies, it is necessary to ensure that there is adequate clearance between the pipeline and the drainage connection. See **Appendix 3.1** and **HyD's Standard Drawing Nos. H 6168, H 6169 and H6170** for details of the restricted zone around deep sump gullies.
- (xiii) When handling AC pipes, special precautionary measures must be taken in accordance with "**Asbestos Work Manual for Maintenance of Asbestos Cement Water Pipes**" regarding their cutting and disposal.
- (xiv) For pipelaying in a new bridge the pipes should be located in a trough accessible from above or supported on concrete/steel works cantilevered from the side of the bridge.
- (xv) When handling polyethylene pipes, special precautionary measures should be taken in accordance with "**Design Guide for Polyethylene Pipelines for Water Supply Purpose**".
- (xvi) When laying pipes in reclaimed areas or at locations that are susceptible to differential settlement, special attention should be given to position appropriate and sufficient flexible joints to prevent leakage or even pipe burst due to uneven settlement. Surrounding the pipes with concrete under this condition must only be made with extreme care especially for steel pipe with welded joints. In the event that ground settlement has induced sufficient stress to open up the welded joints, the surrounding concrete will become an obstacle to the repair operation.

3.6 Thrust Blocks

Thrust blocks prevent pipes from being moved by forces exerted within the

pipe arising from the internal pressure of the pipeline or the flow of water hitting bends, tapers and closed or partially closed valves. The size of a thrust block is dependent upon the deflection of the flow and the head of water inside the pipe. Refer to “**Guidance Note on the Design of Thrust Blocks for Buried Pipelines**” in designing thrust blocks. Typical details of thrust blocks, including horizontal and vertical bend blocks, tee block, taper block and end block, are shown in **Standard Drawing WSD 1.4**.

(i) For Flexibly Joined Pipes

Thrust blocks are essential on flexibly joined pipelines where any pipe movement would open up the joints in the line and cause water leakage. They should be provided to all bends, branches and tapers and pipe ends to take the full thrust unless special design is provided. However, they should not rely on lateral soil pressure for their stability because in Hong Kong situation, there is a high risk that the soil is removed by other parties without notifying WSD.

(ii) For Steel Pipes with Welded Joints

For buried steel pipes of diameter 1200 mm and under and subject to a working head of less than 100 m, there is no need to provide any thrust blocks for bends of less than 45°. For bends of 45° and greater, it is sufficient to design thrust blocks to resist 50% of the thrust. However, in both cases, there must be no loose joint (such as bolted collars or those joints normally used for valve installations) within 30 m on either side of the bend; otherwise the full thrust must be resisted by thrust blocks.

Unless it is known that the full thrust is being resisted by a thrust block, repairs, connections and branches to an existing steel main within 30m from a bend, if unavoidable, should be effected without introducing a loose joint (e.g. by using welded collars or harnessed couplings). Similarly valves should not be inserted within this distance unless harnessed flange adaptors are used or additional thrust blocks are provided to take the full thrust.

For steel pipes of diameter larger than 1200 mm or for pipes subject to more than 100 m working head, design of thrust blocks needs individual consideration to provide a higher safety factor. Thrust blocks must be provided for all bends on exposed steel pipes to resist the full thrust regardless of the diameter of the pipe.

(iii) For Polyethylene Pipes

PE pipes are joined using butt fusion joints, electrofusion joints, compression joints with end load resistance or mechanical joints with end load resistance. Therefore, the design of thrust blocks should generally follow similar line to steel pipelines. **“Design Guide for Polyethylene Pipelines for Water Supply Purpose”** provides further design guidelines on the thrust blocks for PE Pipes.

The design of thrust block should follow the procedures similar to those for steel pipelines where joint continuity is assumed to take half of the thrust. For buried PE pipes with NS90 or below which is subject to a working pressure of 8 bars or less, thrust blocks for all bends which are less than 45° are not required.

3.7 Transverse Anchor Blocks

Where mains are laid up slopes, they should be anchored with concrete at the centre of each pipe to prevent movement. Typical details of anchor blocks are shown in **Standard Drawing WSD 1.5**. The spacing of transverse anchors depends on the gradient of the pipeline and is shown below:

Gradient	Spacing (m)
1 in 2 or steeper	5.5
Below 1 in 2 to 1 in 4	11.0
Below 1 in 4 to 1 in 5	16.5
Below 1 in 5 to 1 in 6	22.0
Flatter than 1 in 6	Normally not required

3.8 Nitrogen Gas Test for Steel Pipes

The spigot and socket joints in steel pipes of DN700 and above should be tested after welding internally and externally and before backfilling by the nitrogen gas test in accordance with the requirements as detailed in **Clauses 22.78 - 22.80** of **“General Specification for Civil Engineering Works”** (GS).

3.9 Backfilling

Regardless of the type of pipe material, proper handling of backfilling operations is important to provide a good protection to the pipe and to avoid undue settlement of the backfilling materials.

Backfilling involves two operations, deposition and compaction. The backfill material should be good soil which does not contain any rock. Backfill material around pipes should be deposited in layers not exceeding 100 mm thick to a level of 300 mm above the top of the pipes. The material in this zone shall be deposited in such a manner that the layer on one side of the pipe is not more than 100 mm higher than the layer on the other side and shall then be compacted by hand-rammers or manually operated power equipment to obtain a relative compaction of at least 95% from trench bottom to the top of the pipes and at least 85% within 300 mm above the top of the pipes. The material on top of the 300 mm level should be deposited and compacted to at least 95% relative compaction.

Common practice of backfilling to pipes involves a two-stage procedure: partial backfilling before hydrostatic pressure tests and complete backfilling after tests. The partial backfill usually leaves the joints exposed or covered only by a relatively shallow layer.

In order to assist the identification of water mains and to serve as a prior warning to trench diggers of water mains underground, a polyethylene identification tape should be placed on top of all newly-laid metallic water mains including diversion mains during the course of backfilling. For all newly-laid buried non-metallic water mains including diversion mains, in addition to the identification tape, a detectable warning tape should be fixed onto the pipe body. Details of the identification tapes and detectable warning tapes are shown in **Standard Drawings WSD 1.31** and **1.37** respectively.

In case any existing water mains are exposed during the course of connection works or repair works, identification tapes should be placed on the top of the exposed water mains as far as possible. However, there is no need to place identification tapes when they are exposed by utilities undertakers to prevent accusations of delaying their works and subsequent claims. Generally, there is also no need to place detectable warning tapes on top of a short section of existing non-metallic water mains when they are exposed by WSD or other utility undertakers. It will not be useful to provide isolated pieces of detectable warning tapes unless they are joined together and extended to the terminal connection points at valve pits.

3.10 Hydrostatic Pressure Test

On completion of mainlaying and before putting the water mains into service, every section of the water main, including the washout pipes, must be hydrostatically tested and the test results recorded (see sample record form in **Appendix 3.2**). The procedure and the compliance criteria of the tests should be in accordance with the requirements detailed in **Clauses 22.81 - 22.83** and **Appendix 22.1** of **GS**.

The leakage should not exceed 0.02 litre per millimetre of nominal diameter of the pipe, per kilometre length, per 24 hours per 10 metre of average test head of the pipeline under test. For PE pipelines, the procedures and the compliance criteria of the test should be in accordance with the requirements detailed in the Model Tender Documents. In case a pipeline is to be tested with a flowmeter connected, manufacturer's prior confirmation that the flowmeter can withstand the hydrostatic pressure for the specified test duration should be obtained.

It is recommended that a pipeline undergoing pressure test be segmented so that the test is conducted against end caps or blank flanges which are adequately anchored and that the pipeline is reasonably free of air. A pipeline fill plan should be prepared to exhaust air from the pipeline as fully as reasonably possible in order to avoid possible hazard of compressed air trapped in the pipeline. Care should be taken on the presence of residual pressure within the pipeline during dismantle of end caps or blank flanges and proper arrangements should be made for disposal of water from the pipeline after completion of hydrostatic pressure tests.

3.11 Cleaning and Sterilisation of Fresh Water Mains

All new fresh water mains, repaired mains and mains for making connections must be cleaned and sterilised, in accordance with **Clauses 22.73 and 22.84 of GS and DI No. 805 "Mainlaying - Cleaning and Sterilisation of Fresh Water Mains"**, before being put into service.

(i) For New Mains

Before a pipeline can be considered ready for service, it should be cleaned internally as thoroughly as possible to ensure that no foreign matter remains inside the water mains. For long lengths of small diameter mains (with size not exceeding DN600), swabbing should be carried out to remove dirt and materials inadvertently left in the pipeline. For larger diameter mains, a CCTV survey should be carried out to inspect and assess the internal conditions of the pipeline.

If the pipeline is intended to carry potable water, it should be disinfected by completely filling with water that has been dosed with a homogeneous solution of chloride of lime (or sodium hypochlorite solution) such that the final concentration of free chlorine in the water is at least 30 ppm. The water shall be left in the pipeline for at least 24 hours. The pipeline should be drained down and flushed thoroughly with potable water, until the concentration of the remaining chlorine is less than 1 ppm. Water samples will then be taken for bacteriological,

metal, physical and chemical analyses. The pipeline can only be put into service after the test results are found to be satisfactory.

(ii) For Repaired Mains and Mains for Making Connections

All fractured mains, and every main into which an opening has been made for any causes whatsoever, should be sterilised with chloride of lime (or sodium hypochlorite solution) so as to achieve a concentration of free chlorine of at least 30 ppm in the water before putting back to service. Sterilisation should be carried out on the whole section of the main which has been shut down for the purpose of making the repair and opening. The point of application of chloride of lime (or sodium hypochlorite solution), whether it be a ferrule or a hydrant, should be as near to the charging valve as possible. The applied chloride of lime (or sodium hypochlorite solution) should be flushed out through the fire hydrants or washout valves in the vicinity.

An exception can be made where a gate valve is dismantled for repair, cleaning, etc. In such cases the valve parts should be swabbed with chloride of lime. The main is then charged with sufficient water for discharge through the hydrant or washout on the downstream side of the repaired valve until it is certain that the discharged water has passed through the repaired valve.

Water samples should be taken from the pipes for testing of bacteriological content in order to ensure that the pipes have been adequately sterilised.

3.12 Cathodic Protection of Water Mains

Cathodic protection is commonly installed in the laying of new pipelines of mild steel and ductile iron to cater for aggressive ground condition. It is designed for providing corrosion protection for large diameter underground or submarine pipelines. There are two main types of cathodic protection systems devised for protection of pipelines, namely sacrificial anode cathodic protection (SACP) and impressed current cathodic protection (ICCP).

It involves feeding of a direct electric current from sacrificial anodes or an impressed current source through the electrolyte (i.e. soil or water) to the metallic pipeline. Typical layouts of these two types of cathodic protection systems, i.e. SACP and ICCP, are shown in **Appendix 3.4**.

The design of cathodic protection system shall be carried out by a Certified Cathodic Protection Specialist of NACE International or Professional Member

of Institute of Corrosion. The cathodic protection design shall conform to the relevant international standards. The cathodic protection current requirements shall be determined by considering the coating deterioration factor for 50 years based on the international standards.

3.12.1 Soil Test to Hong Kong Geoguide 7

Soil test in accordance with paragraph 4.3.3 of Hong Kong Geoguide 7 shall be carried out on soil samples taken at strategic points along the mainlaying route. Under the Hong Kong Geoguide 7, the following soil properties of soil samples shall be tested and different marks will be assigned to the tested items based on the test results :

- (i) Soil Composition
- (ii) Resistivity (Ohm-cm)
- (iii) Moisture Content
- (iv) Groundwater Level
- (v) pH
- (vi) Soluble Sulphate (ppm)
- (vii) Made Ground
- (viii) Chloride Ion (ppm)

The total mark of a soil specimen is then calculated by summing up individual marks of the test items. The classification of soil aggressivity is determined by the total mark obtained as shown in the table below :

Classification of Soil Aggressivity	Total Mark from the Soil Aggressivity Assessment
Non-aggressive	≥ 0
Mildly aggressive	-1 to -4
Aggressive	-5 to -10
Highly aggressive	≤ -11

It is recommended that cathodic protection shall be installed for metallic water mains laid in aggressive and highly aggressive soils. For critical water mains laid in mildly aggressive soil, cathodic protection shall also be installed to provide additional protection against corrosion.

The need for installation of cathodic protection for an underground pipeline shall be assessed section by section based on the aggressivity of the soil sample taken in the vicinity of the corresponding water main section. By installing isolating connections, cathodic protection can be applied section by section accordingly.

3.12.2 Site Survey before Cathodic Protection Design

General site inspection on the type of site terrain and vegetation as well as characterization of the land including urban area, industrial area, farm land, forest, open field, swamps, rocks etc., shall be taken into account. Other relevant features, such as rivers, streams, nullahs, railways, main roads, overhead power lines and underground facilities of other public utilities, that cross the mainlaying route shall be taken into account in the design of cathodic protection at such crossing points. Also, presence of common or other plant earthings shall be taken into account to avoid loss of cathodic protection current due to connection to such earthing points.

Relevant information and drawings of underground facilities or cathodic protection systems from the utility companies, other government developments and relevant parties, if exists, in the vicinity of the proposed SACP system shall be obtained and studied on their mutual effects.

3.12.3 Sacrificial Anode Cathodic Protection

The SACP system shall be designed to supply a minimum of 10mA/m^2 on the steel (bare) pipeline surface. The instant-off potential for cathodic protection of the pipelines shall be in the range between -850mV and -1100mV with respect to a copper/copper sulphate reference electrode (CSE). The CSE shall be positioned in the soil directly above or adjacent to the pipeline. In the presence of active sulphate reducing bacteria (SRB) in soil with anaerobic environments, the cathodic protection potential shall be designed at -950mV versus CSE.

In general, the anodes shall be of high potential magnesium alloys pre-packaged with chemical backfill material in non-polarized cotton bag. At

least 0.5% of the total number of anodes shall be randomly selected for quality testing conducted by a HOKLAS accredited laboratory on electrochemical properties in accordance to ASTM G97 before installation.

The anode block strings shall be installed horizontally at a depth between the bottom and the centerline of the pipeline with a minimum distance of 300mm away from the pipeline. For pipelines with a nominal diameter of 800 mm or bigger, anode block strings shall be installed on both sides of the pipeline to ensure uniform distribution of cathodic protection current along the pipeline. Calculation on the number of anodes to be required shall be submitted to substantiate the design including the following design parameters:-

- (a) Design current demand based on the pipe dimensions and design current density.
- (b) Anode mass required based on the current demand, design life, anode consumption rate and utilization factor assumed.
- (c) Anode-to-soil resistance based on soil resistivity, length of anode, equivalent diameter of anode in backfill, depth to centre of anode and spacing of anodes.
- (d) Anode current output based on design protection potential, design close-circuit potential and anode-to-soil resistance.

Based on the results of design calculation, the number of pre-package anodes to be required and the proposed anode arrangement shall be determined accordingly.

(i) Anode Station

The cables from the anode block strings shall be laid to an anode station, which is an underground concrete chamber equipped with an IP68 plastic cable box and cabling facilities leading to the pipeline. The cable box shall be equipped with cable terminal blocks for connection of cables from the anode block strings and the cables connecting to the pipeline. The magnitude of current flowing from the anode block strings to the pipeline shall be derived from the millivolt drop across an 0.1 ohm calibrated wire shunt, which shall be installed in the cable box to facilitate such purpose.

(ii) Test Station

To facilitate measurement of protection potential on the pipeline, test stations shall be provided along the pipeline. The test station is an

underground concrete chamber equipped with an IP68 plastic cable box and cabling facilities leading to the pipeline and a copper/copper sulphate reference electrode (CSE). The cable box shall be equipped with cable terminal blocks for connection of a cable from the pipeline and a cable from the CSE. Testing terminals to facilitate measurement of the protection potential of the pipeline against CSE with a high input impedance multi-meter. To facilitate calibration of the CSE with a portable half-cell, a shaft cathodic test box with a diameter of 150mm shall be provided at the bottom of the test station chamber as shown in Appendix 3.4.

(iii) Cable to Pipe Connections

For mild steel pipelines, connection of cables to pipeline shall be via studs welded on external surface of the pipeline. For ductile iron pipes, thermite welding of bolts/stud shall be used for connection of cables. In general, iron oxide and powdered aluminum welding material shall be used.

The cable connections shall be fully encapsulated using two-pack epoxy resin. Any damage on the external coating of the pipeline during welding, cable connection and other observed coating defects shall be properly repaired. Typical pipe connection details are shown in **Appendix 3.4**.

(iv) Cables

Single core non-armoured copper cable with XLPE insulated PVC sheathed cable shall be used. For connection to anodes and reference electrodes, cables shall be brown and black in colour respectively. For connection to pipelines or for continuity of pipeline sections, cables shall be grey in colour. Voltage drop calculation shall be submitted to substantiate cable size. Each cable shall be numbered for easy identification. Cable tags, in form of plastic rings, showing cable numbers shall be installed at cable ends with a numbering system as detailed below:-

(a) Cable from anode to anode station :

Gxx-Ayy-B01-S (Brown)



Spare anode block (if "S" exists)
Anode block no.
Anode no.
Water main group no.

- (b) Cable from pipe to anode station :
Gxx-Ayy-P01 (Grey)

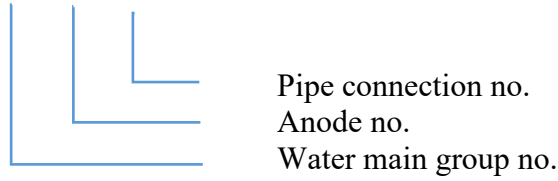

- (c) Cable from reference electrode to test station :
Gxx-Tyy-R01 (Black)

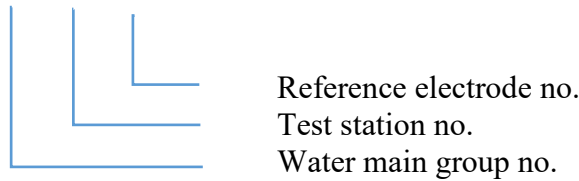

- (d) Cable from pipe to test station :
Gxx-Tyy-M01 (Grey)

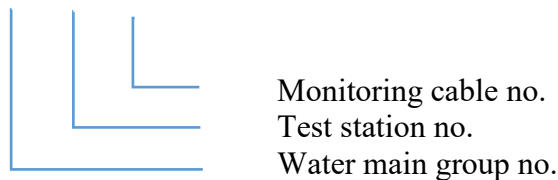

- (v) Cable Termination Cover on Pipeline

All cable connections to the external surface of pipeline shall be covered with prefabricated, primerless and self-adhesive protection caps. The protection cap shall be made of elastomer, polymer-based compound or wax-patch material and conform to a variety of profiles and designed to provide mechanical protection for buried applications.

3.13 Service Connections and Integrating New and Existing Distribution System

Prior to making connection to live mains, engineers and inspectors should ensure that water mains are correctly identified and inspectors should brief works supervisors to ensure that all connections are correctly made. For cases where fresh and salt water mains are of the same size and of the same type of material, identification of salt water mains should be made by the chloride strip test. See **DI No. 853 “Procedures for Identification of Fresh and Flushing Water Mains”** and **Appendix I – “Chloride Strip Test for Salt Water”** attached to the DI.

Similarly, prior to making service connections for new application of water supply or reinstating service connections during R&R works, engineers and

inspectors should ascertain the legitimacy of the service connections in order to avoid making/reinstating illegal connections, thus minimising loss of water. Care should be taken to avoid picking up connections to abandoned tees during R&R works. See **Appendix 3.3** for guidelines in making replacement service connections in R&R Works. If suspicious tees are reinstated for other overriding reasons, proper records should be kept to enable subsequent follow-up action to verify the legitimacy of the connections.

Supply interruption is often necessary for making connections to existing mains. See also **DI No. 803 “Planned Interruption to Water Supplies”** for the planning of interruptions to water supply and the procedures of arranging advance notification to customers.

3.14 Fire Hydrants

The locations of fire hydrants are normally agreed in consultation with the Fire Services Department (FSD) at the design stage. As a general guide, fire hydrants are normally spaced 100 m apart. Fresh and salt water fire hydrants should be located alternately where both systems exist. Where possible, and consistent with the requirements of FSD, hydrants should be installed at high points or low points in the systems for the additional purpose of releasing air or draining the main respectively.

Pedestal hydrants are installed on DN150 or larger mains. Swan neck hydrants are installed on DN80/100 fresh water mains. See **Standard Drawings WSD 1.54** and **WSD 1.55** showing the details of pedestal and swan neck hydrants respectively. All new installation for fire hydrants should be of pedestal type. Swan neck hydrants are installed only when the capacity of the distribution system is limited. See **Appendix 3.7** for installation of pedestal and swan neck hydrants.

Fresh water hydrants and salt water hydrants are painted red and yellow respectively. Non-servicing fire hydrants are to be distinguished from servicing hydrants by having their caps painted blue. Hydrants connected to a trunk main are distinguished from other by having a white band painted on them. See also **Standard Drawing WSD 1.34**.

For further details, see **DI No. 863 “Guidance Notes on Installation and Maintenance of Fire Mains and Hydrants”**.

3.15 As-built Records of Water Mains

Engineers and inspectors should follow the documents as shown below when

submitting records of water mains and details of valves and fire hydrants to the Drawing Office for incorporation into the DMS, and Valve Reference Numbering System Database and Fire Hydrants Reference Number Central Register:

Record	Relevant Document
Newly-laid, Diverted, Replaced or Rehabilitated Water Mains	Operations Branch Instruction No. 02/2008 (Distribution) (or its latest revision issued by Operations Branch): Submission of As-built Records of Water Mains and Valve Details Record Sheets (using Form WWO 85)
Shallow Covered Water Mains	Supply & Distribution Branch Instruction No. 2/95 (Distribution) (or its latest revision issued by Operations Branch): Notification Form for Shallow Covered Water Mains (form attached at Appendix 3.8)
Gate Valves	Operations Branch Instruction No. 02/2005 (Distribution) (or its latest revision issued by Operations Branch): Valve Reference Numbering System and Valve Reference Number Plate (using Form WWO 546)
Fire Hydrants	DI No. 863: Guidance Notes on Installation and Maintenance of Fire Mains and Hydrants (using Form WWO 504 and WWO 505)

See **Appendix 3.9** showing the sign conventions and designations for the mains records.

SECTION 4 - REPAIR, REHABILITATION, OPERATION AND MAINTENANCE OF WATER MAINS

4.1 Repairs to Mains and Submains

When a water main bursts, the extent of the area affected and the problems caused should be assessed and positive action taken immediately. Interruption of water supply for a short period is inconvenient to consumers and that for any prolonged period is intolerable. Thus an attempt must be made to restore the supply at the earliest opportunity. Should a lengthy delay be inevitable, plans must be made to provide an alternative or emergency supply. In addition, the consumers affected should be made aware of the interruption of water supply and how soon water supply can be restored. If the affected area is large, announcement through the departmental homepage and/or radio announcement should be made.

DI No. 802 “Main Bursts and Emergency Maintenance of Water Mains” and **“Guidance Notes on Handling Main Bursts and Emergency Maintenance of Water Mains (June 2006)”** attached therein outlines the action required following the report of bursting of a water main.

For standard methods for repairs to cast iron, asbestos cement and UPVC water mains, see **Appendix 2.6**. For repair to cast iron pipes, refer to the table below for guidance on the recommended repair method for various types of cast iron joints (see **Appendix 2.7** for details of the joints).

From	To	Recommended Repair Method
DI plain end	CI spigot (including Tyton joint) or bolted gland spigot or screwed gland spigot	Use DI change collar
	CI socket (including Tyton joint) or bolted gland socket or screwed gland socket	Cut off socket and use DI change collar
	CI flange	Use DI flange socket piece

Particular attention should be given to the requirement as stated in item (xiii) of Section 3.5 when making repair to asbestos cement pipes. When repairing steel pipes near a bend, the requirements stated in Section 3.6 should be complied with.

4.2 Leak Detection

Apart from the establishment of DMAs and PMAs for monitoring and control of leakage, leak detection on the water supply system is required to identify and locate any leak in the system for repair at an early stage in order to reduce water loss. For details of leak detection work, please see **DI No. 828 “Leak Detection”** and **Waste Detection Manual**.

4.3 Draining of Mains Through Washout Valves

Washout valves are normally provided at low points for draining the mains to facilitate repair or connection work. The water may be discharged to a nullah/stream course or into a pump pit where it is pumped away immediately. In either case, care has to be taken to prevent contamination of the mains, particularly when the washout valve is in the open position.

(i) For Water Discharging into Nullah/Stream Course

- Before draining, the works supervisor should ensure that the washout is not submerged.
- After draining operation, the works supervisor should double check to ensure that the washout valve is closed tightly.

(ii) For Water Discharging into Pump Pit

- Regular inspection and cleaning should be carried out to ensure that the pump pit is kept dry and clean especially during the wet seasons and for those pump pits that have a high risk of contamination.
- Before draining, the works supervisor should ensure that the pump pit is pumped dry, all debris removed and flushed clean
- After draining operation, the works supervisor should double check to ensure the washout valve is closed tightly.

In order to facilitate regular flushing of the dead-end mains adjacent to district boundary valves, special consideration should be given to provide a hydrant or washout in an arrangement as shown in **Appendix 4.1**.

4.4 Rehabilitation of Water Mains

4.4.1 General

The conventional method for laying of water mains and replacement of aged water mains is the open cut method involving digging a trench along the length

of the proposed water main, placing the water main in the trench on suitable bedding materials and then backfilling. Such method may involve opening of road along the proposed water main. This will generally be acceptable when the traffic and environmental impacts arising from the open cut method are not serious, and when the underground utilities present are not congested.

At locations where traffic and/or environmental impacts could not be mitigated satisfactorily, the use of trenchless techniques should be considered. These techniques are sometimes referred to as the “minimum dig” techniques, in order to accurately indicate that such methods still require the opening of pits. Trenchless water mains replacement techniques involve the pre-drilling of a hole of suitable diameter and subsequently the insertion of a new main along the hole formed. Common trenchless techniques include pipe jacking, horizontal directional drilling and micro-tunnelling. As these techniques need to avoid the already congested underground utilities, the pipelines will be laid deep underground which may lead to operation and maintenance problems.

Apart from laying a replacement water main by trenchless techniques, rehabilitating an existing pipeline can also be considered provided that the existing pipeline can be taken out of service without affecting water supply to customers (e.g. when an alternative pipeline is available for supply or a temporary main can be installed). Rehabilitation is defined as a method for restoring or upgrading the performance of an existing pipeline using an in-situ renovation process, in order to restore or improve the performance and extend the service life of an existing pipeline. Normally, a “new” pipe is launched from a “launching pit” and travels along the existing pipe (i.e. the host pipe) to a “receiving pit”. The “new” pipe can travel up to about 100 m to 200 m under ideal situation. However, in practice, bends, tees, tapers and other fitting along the host pipe would shorten the length of the water main to be rehabilitated in each operation.

4.4.2 Classification of Rehabilitation Methods

There are a number of lining systems available for rehabilitation of water mains. They are in general classified as non-structural, semi-structural and fully structural lining systems.

A non-structural lining system relies wholly on the strength of the host water main. The system is usually in the form of providing a coating (e.g. cement mortar, epoxy or other material) bonded to the inside wall of the water main to protect against internal corrosion. As the coating is usually thin and cannot take loadings by itself, it is only appropriate for pipes which are structurally sound and show no signs of leakage.

A semi-structural lining system relies on the strength of the host water main. The lining should be capable of spanning over defects (e.g. holes and gaps) in the host pipe. The lining is not a structural replacement for the host pipe, but should work compositely with it to prevent further internal corrosion/leakage and enhance the structural integrity of the whole water main.

A fully-structural lining system does not rely on the strength of the host water main, and is capable of withstanding the external and internal loads including possible negative pressures during the course of emptying the water main. However, in view of the lining thickness, the hydraulic performance of the lining system should be assessed.

It is considered that a fully-structural rehabilitation method should be adopted for asbestos cement and cast iron pipes, as these pipes are brittle and are prone to sudden and catastrophic failure.

4.4.3 Overview of Rehabilitation Methods

Commonly Adopted Rehabilitation Methods

- (i) “Close Fit Lining” is defined as a lining system, which when in service, forms a tight fit interfacing lining with the existing host pipe. Typical techniques are those in which a PE lining is temporarily reduced in size by folding into C-shape or swaging concentrically, and is then reverted to its original size (either naturally or under pressure) after insertion into the host pipe. Close Fit Lining can be fully structural or semi-structural depending on the type of PE lining used. Fully structural PE lining is preferred for future maintenance purpose. Pipes rehabilitated by Close Fit Lining are designated as “RB” or “RE” in the DMS, for lining formed by the “Fold and Form” System and “Swagelining” System respectively. “RB” is the most common rehabilitation method that has been adopted. For details of the designation system, see **Appendix 3.9**.
- (ii) “Cured-in-Place Pipe” (CIPP) is defined as a flexible polymer or glass fibre fabric lining impregnated with thermosetting resin and subsequently inserted into position on the inner wall of the host pipe by means of fluid/air pressure. When completely cured, the installed lining forms a watertight pipe-within-a-pipe system inside the host pipe. CIPP and its end seal normally work compositely with the host pipe and perform semi-structurally in most situations. It is designated as “RA” in the DMS.

- (iii) “Sliplining” is defined as a method of fully structural rehabilitation that involves winching a butt fusion welded PE pipe inside the host pipe, and then fully grouting the annulus between the two pipes. It is designated as “RD” in the DMS.

Other Rehabilitation Methods

- (iv) “Pipe Bursting” is defined as a method of rehabilitation that involves bursting of the existing water main by a pneumatic or hydraulic bursting tool. Fragments of the existing water mains are pushed into the surrounding soil by a spreader and a new pipe is installed in the vacated space. The main concern is that ground movements during the pipe bursting operation may damage nearby utilities or structures. Its application is limited by the fact that the underground utilities in Hong Kong are congested and are vulnerable to being damaged by the bursting process. It is designated as “RC” in the DMS.
- (v) “Internal FRP Layer Lining” is defined as a method of semi-structural rehabilitation that involves removal of the remaining internal protective coating from an existing pipeline, preparation of the pipe surface, and then installation of layers of overlapping sheets of fibre reinforced polymer for bonding to the internal surface. It is designated as “RF” in the DMS.
- (vi) “External FRP Layer Wrap” is defined as a method of semi-structural rehabilitation that involves removal of the remaining external protective coating from an existing pipeline, preparation of the pipe surface, and then wrapping of the pipe with layers of overlapping sheets of fibre reinforced polymer sheets. It may be considered as fully structural if exceptionally thick FRP layer is applied. It is designated as “RF” in the DMS.
- (vii) “Automated Internal Coating Replacement” is defined as a method of non-structural rehabilitation that involves removal of the remaining internal protective coating from an existing pipeline, preparation of the pipe surface and then automated in-situ spray application of a replacement epoxy coating. Pipe condition survey may be carried out to identify defects for rectification and improvement works to enhance the pipe structure before application of the replacement coating. It is designated as “RG” in the DMS.
- (viii) “Manual Internal Coating Replacement” is defined as a method of non-structural rehabilitation that involves removal of the remaining internal protective coating from an existing pipeline, preparation of the pipe surface and then manual in-situ spray application of a replacement

epoxy/polyurethane coating. Pipe condition survey may be carried out to identify defects for rectification and improvement works to enhance the pipe structure before application of the replacement coating. It is also designated as “RG” in the DMS.

- (ix) “External Coating Replacement” is defined as a method of non-structural rehabilitation that involves removal of the remaining external coating from an existing pipeline, preparation of the pipe surface and then manual in-situ spray application of a replacement epoxy coating. Pipe condition survey may be carried out to identify defects for rectification and improvement works to enhance the pipe structure before application of the replacement coating. It is designated as “RH” in the DMS.

Possible size of the host pipe and characteristics of the lining for various methods of rehabilitation are listed below:

Type of rehabilitation	Possible size of host pipe	Characteristics of lining
Close Fit Lining (Fully-structural)	DN150 – DN1400	PE100 pipe (SDR 17 or below)
Close Fit Lining (Semi-structural)	DN600 – DN900	PE100 pipe (SDR above 17, depending on the required hole/crack bridging capability)
Cured-in-place Pipe (Semi-structural)	DN150 – DN1400	An outer polyester jacket, internal PE coating and a flexible polymer or glass fibre fabric layer impregnated with thermosetting epoxy
Sliplining	DN600 – DN1400	PE100 pipe (SDR 17 or below) with annulus between the lining and the host pipe to be fully grouted
Internal FRP Layer Lining (Semi-structural)	DN900 – DN1400	Layers of overlapping sheets of fibre reinforced polymer impregnated with epoxy (thickness depending on the required hole/crack bridging capability)
External FRP Layer Wrap (Fully Structural/ Semi-structural)	DN450 – DN1400	Layers of overlapping sheets of fibre reinforced polymer impregnated with epoxy

The advantages and disadvantages of various methods of rehabilitation are summarised in **Appendix 4.2** for reference.

4.4.4 Procedures for Rehabilitation of Water Mains

The procedures for rehabilitation of water mains by various methods have been consolidated from the submissions furnished by the contractors of recent R&R contracts, and are for general reference only. Engineers and inspectors are advised to exercise their own judgments in adopting the most suitable method of rehabilitation and evaluating the method statements submitted by contractors, taking into account of all relevant site specific factors, including, but not limited to, the availability of space and the condition of the existing main to be rehabilitated.

Close Fit Lining

Step 1: Preparatory Work

Construct a launching pit (for insertion of PE close fit lining and towing head) and a receiving pit (for accommodation of winch and associated equipment).

Step 2: Pre-lining CCTV Survey, Pipe Cleaning and Local Repair

Carry out CCTV survey to assess the condition of the host pipe. Clean the pipe to remove silt, rust, tuberculation, deposits, remains and other foreign materials by means of wire brushes, scraper or pressure jetting. Carry out CCTV survey again as necessary to confirm that the host pipe has been cleaned satisfactorily. For mains to be rehabilitated by semi-structural lining, carry out local repair works for the host pipe as necessary.

Step 3: Removal of Obstructions

Identify possible obstructions, such as protruding branch connections, displacement at joints or excessive deformation of the host pipe, and remove the obstructions before commencement of installation of lining.

Step 4: Measurement of Dimension of Host Pipe

Use an appropriate prover of dimensions and/or carry out laser measurements for measuring the internal diameter and ovality of the host pipe to confirm suitability of the proposed lining, and to ensure its free passage along the host pipe.

Step 5: Temporary Deformation of Lining

Fold the lining into C-shape in factory or in-situ on site by a suitable deforming device to facilitate the winching of the deformed lining from the launching pit to the receiving pit. Alternatively, deform the lining concentrically (by reducing its diameter) by swaging through a set of static die rollers or an array of compression rollers, to facilitate the insertion to the host

pipe by winching.

Step 6: Insertion of Lining

Insert the lining by using a winch located at the receiving pit to pull a winching wire attached to a towing head together with the deformed lining. All lining should be joined by a suitable butt fusion machine, with the external beads formed at joints properly removed by a debanding equipment.

Step 7: Reversion of Lining

For concentrically deformed lining, it will normally revert to its original dimension and press tightly against the host pipe once the tension of the winching wire is released. For lining deformed into C-shape, both ends of the lining will be sealed and pressurised air will be injected into the annulus for reversion of its original shape to make it fit tightly against the host pipe. Sufficient time should be allowed for longitudinal recovery of the lining after the completion of winching.

Step 8: Post-lining CCTV Survey and Hydrostatic Pressure Test

Carry out CCTV survey again to check the condition of the rehabilitated main. Expand the lining to the nearest PE pipe standard size and install a steel insert/support bush at both ends of the exposed lining for ensuring the dimensional accuracy for subsequent electrofusion to a stub flange. See **Appendix 4.3** for details. Use an industrial hairdryer to further soften the lining during the expansion process, if necessary. The ends of the rehabilitated mains are now prepared for hydrostatic pressure test.

[Remark: Expansion of lining is not required if (1) a suitable electro-fusion step coupler is available for connecting the PE lining and the standard PE stub flange directly; or (2) suitable proprietary flange adaptor is available for connecting the lining.]

Step 9: Connection to Existing Mains and Pit Reinstatement

Connect the flange ends of the lining to the existing mains by conventional methods, backfill and reinstate the pits.

CIPP

Step 1: Preparatory Work

Construct a launching pit (for insertion of CIPP lining) and a receiving pit (for accommodation of winch and associated equipment).

Step 2: Pre-lining CCTV Survey, Pipe Cleaning and Local Repair

Carry out CCTV survey to assess the condition of the host pipe. Clean the pipe to remove silt, rust, tuberculation, deposits and other foreign materials by means of wire brushes, scraper or pressure jetting. Carry out CCTV survey

again as necessary to confirm that the host pipe has been cleaned satisfactorily. For mains to be rehabilitated by semi-structural lining, carry out local repair works to the host pipe as necessary.

Step 3: Removal of Obstruction

Remove thoroughly the internal coating of the existing deteriorated host pipe, such as bitumen or cement mortar lining. Identify possible obstructions, such as protruding branch connections, displacement at joints or excessive deformation of the host pipe, and remove the obstructions before commencement of installation of lining.

Step 4: Measurement of Dimensions of Host Pipe

Carry out laser measurements for measuring the internal diameter and ovality of the host pipe to facilitate the fabrication of lining.

Step 5: Preparation of Lining

The lining consists of an outer polyester pressure jacket, an internal polyethylene coating and a felt layer impregnated with resin. The resin, usually comprising a two-component thermosetting non-shrinkage epoxy, is mixed thoroughly by electrical equipment. The mix is then pumped into the lining tube and spread evenly throughout using rollers.

Step 6: Insertion of Impregnated Lining into Host Pipe

Insert a pre-lining to the host pipe as necessary, in order to protect the resin if infiltration from the host pipe is apparent as indicated in the CCTV survey. The lining should be installed to the host pipe by inversion using compressed air/water to achieve simultaneous insertion and inflation.

Step 7: Curing and Hardening of Lining

Cure the resin by using hot water/steam to achieve full curing. Wait for the resin to cool down and harden.

Step 8: Installation of Sealing System at Pipe Ends

Cut back the lining with a sufficient length and install the sealing system to protect the bonding between the lining and the host pipe. The system normally comprises a rubber collar and two steel end rings, which are to be installed to make sure that the rubber collar will be in close contact with the lining and the host pipe. Alternatively, the sealing system can be installed between the end of the rehabilitated pipe and a new flange spigot piece without the need for cutting back the lining. See **Appendix 4.4** for details. For small pipes, installing an end ring and applying an epoxy resin for sealing up the interface could be sufficient.

Step 9: Post-lining CCTV Survey and Hydrostatic Pressure Test

Carry out CCTV survey again to check the condition of the rehabilitated main.

Then carry out the hydrostatic pressure test.

Step 10: Connection to Existing Mains and Pit Reinstatement

Connect the flange ends of the rehabilitated main and the existing mains by conventional methods, backfill and reinstate the pits.

Sliplining

Step 1: Preparatory Work

Construct a launching pit (for insertion of PE sliplining and towing head) and a receiving pit (for accommodation of winch and associated equipment).

Step 2: Pre-lining CCTV Survey and Pipe Cleaning

Carry out CCTV survey to assess the condition of the host pipe. Clean the pipe to remove silt, debris, tuberculation and encrustation by means of scraper or pressure jetting. Carry out CCTV survey again as necessary to confirm that the host pipe has been cleaned satisfactorily.

Step 3: Removal of Obstruction

Identify possible obstructions, such as protruding branch connections, displacement at joints or excessive deformation of host pipe, and remove the obstructions before commencement of installation of lining.

Step 4: Proving of Dimension of Host Pipe

Carry out a proving test by pulling a short length of pipe with a suitable size within the host pipe to confirm the absence of obstruction and ensure successful insertion of the lining.

Step 5: Insertion and Jointing of Lining

Insert the lining by using a winch located at the receiving pit to pull a winching wire attached to a towing head together with the deformed lining. All sliplining should be joined by a suitable butt fusion machine, with the external beads formed at joints properly removed by a debanding equipment. When the sliplining emerges from the receiving pit, the tension of the winching wire is released. Sufficient time should be allowed for longitudinal recovery of the lining after the completion of winching.

Step 6: Grouting after Lining and Preparation of Pipe Ends

Inject free flowing cement grout, normally under pressure, to fill up the annulus between the existing pipeline and the newly installed lining. Connect the exposed lining with a stub flange by electro-fusion or a proprietary flange adaptor. See **Appendix 4.3** for details. The ends of the rehabilitated main are now prepared for hydrostatic pressure test.

Step 7: Post-lining CCTV Survey and Hydrostatic Pressure Test

Carry out CCTV survey again to check the condition of the rehabilitated main. Then carry out the hydrostatic pressure test.

Step 8: Connection to Existing Mains and Pit Reinstatement

Connect the flange ends of the lining to the existing mains by conventional methods, backfill and reinstate the pits.

Internal FRP Layer Lining

Step 1: Preparatory Work

Arrange for access into the pipe to be rehabilitated through the existing inspection tee. Strip off the existing internal lining by mechanical scrapper, with the aid of hand tool as necessary. Sharp edges, blurs and welding seams along the pipe to be rehabilitated should be rounded or smoothed by mechanical grinding. Roughen the internal pipe surface and remove any loose rust by wire brush. Serious pitting on pipe surface due to corrosion and large recesses along the pipe should be filled up using cement mortar and epoxy filler respectively.

Step 2: Application of Undercoat

The internal FRP layer lining usually consists of an undercoat formed by epoxy, glass fabric layer(s) impregnated with epoxy and a finishing coat formed by epoxy. For the undercoat, mix the epoxy thoroughly by electrical equipment before applying on the internal pipe surface by roller brush or spatula.

Step 3: Installation of FRP Layer

Apply the fabric layer impregnated with epoxy on the undercoat before the complete curing of the undercoat. Apply a uniform tension along the primary direction of the fabric layer to ensure good adhesion to the internal pipe surface, paying particular attention near pipe joints to avoid air entrapment. Adequate lapping length of the fabric layer along the primary and secondary direction of fabric should be provided. Air voids, if any, should be smoothed by hand to produce a uniform and smooth surface. Repeat this step until the required numbers of fabric layer are installed.

Step 4: Application of Finishing Coat

Apply the finishing coat consisting of epoxy before the complete curing of the last layer of fabric impregnated with epoxy.

Step 5: Installation of Sealing System

Install the sealing system to protect the bonding between the internal FRP layer lining and the host pipe. The system normally comprises a rubber collar and two steel end rings, which are to be installed to make sure that the rubber

collar will be in close contact with the lining and the host pipe. It is quite similar to the sealing system shown in **Appendix 4.4**.

Step 6: Post-lining CCTV Survey and Hydrostatic Pressure Test

Carry out CCTV survey again to check the condition of the rehabilitated main. Then carry out the hydrostatic pressure test.

External FRP Layer Wrap

Step 1: Preparatory Work

Expose the pipe to be rehabilitated if the pipe is partly covered by soil. Strip off the existing external lining by mechanical scrapper, with the aid of hand tool as necessary. Sharp edges, blurs and welding seams along the pipe to be rehabilitated should be rounded or smoothed by mechanical grinding. Roughen the external pipe surface and remove any loose rust by wire brush. Serious pitting on pipe surface due to corrosion and large recesses along the pipe should be filled up using cement mortar and epoxy filler respectively.

Step 2: Application of Undercoat

The external FRP layer wrap usually consists of an undercoat formed by epoxy, glass fabric layer(s) impregnated with epoxy and a finishing coat formed by polyurethane emulsion with zinc phosphate primer. For the undercoat, mix the epoxy thoroughly by electrical equipment before applying on the external pipe surface by roller brush or spatula.

Step 3: Installation of FRP Layer Wrap

Apply the fabric layer impregnated with epoxy on the undercoat before the complete curing of the undercoat. Apply a uniform tension along the primary direction of the fabric layer to ensure good adhesion to the external pipe surface, paying particular attention near pipe joints to avoid air entrapment. Adequate lapping length of the fabric layer along the primary and secondary direction of fabric should be provided. Air voids, if any, should be smoothed by hand to produce a uniform and smooth surface. Repeat this step until the required numbers of fabric layer are installed.

Step 4: Application of Finishing Coat

Apply the finishing coat consisting of polyurethane emulsion with zinc phosphate primer before the complete curing of the last layer of fabric impregnated with epoxy.

Step 5: Installation of Sealing System

Install the sealing system to protect the exposed end of the external FRP layer. The system normally comprises a stainless steel split clamp and two gaskets, which are to be installed to protect the interface between the end of the FRP layer and the host pipe. See **Appendix 4.5** for details.

Step 6: Hydrostatic Pressure Test
Carry out the hydrostatic pressure test.

4.4.5 Maintenance of Rehabilitated Water Mains

The methods for maintenance of rehabilitated water mains have been consolidated from the submissions furnished by the contractors of recent R&R contracts, and are for general reference only. Engineers and inspectors are advised to refer to the operation and maintenance manual submitted by the contractor, together with the as-built drawings of the rehabilitated water mains for details.

Close Fit Lining

Step 1: Preparatory Work

Identify the exact location of the damaged rehabilitated main, and excavate a temporary pit with sufficient size to facilitate the repair work.

Step 2: Removal of Damaged Lining

Use appropriate cutting tools (such as pipe saw, chain cutter, longitudinal pipe cutter, window cutter and/or radial cutter, depending on whether the host pipe is ductile or brittle) for cutting the host pipe and the damaged lining. Flame cutting is prohibited, in order to avoid causing any heat damage to the existing lining. The damaged section of the pipe including the host pipe and the lining is to be cut out. The host pipe is then carefully removed further with a circumferential cut, leaving a section of lining projecting from the cut ends of the host pipe. The length of the cut should leave sufficient space for assembly of the electro-fusion couplers, and the depth of cut should be made to the minimum. Carefully hammer the host pipe to see if the cut section can be detached.

[Remarks: (1) The exposed lining installed previously by swaging should be clamped either by split-clamps or fusing taping tee to prevent any possible reversion into the host pipe due to excess strain. (2) In some cases electro-fusion patch or repair saddle can also be used to repair small puncture along the damaged lining, as long as the water flow can be stopped and the repair area is kept dry during the repair process.]

Step 3: Installation of Replacement Pipe and Pit Reinstatement

Expand the projected lining to the nearest PE pipe standard size and install a steel insert/support bush to the end of the exposed lining for ensuring the dimensional accuracy for subsequent electro-fusion to a stub flange. See **Appendix 4.3** for details. Use an industrial hairdryer to further soften the PE lining during the expansion process, if necessary. Scrap the lining using scraper cylinder or hand pipe scrapers to remove the oxidised outer surface of

the lining, if needed. Connect the existing lining at the two projected ends with the replacement pipe. The replacement pipe should be concrete surrounded (if required), followed by backfilling and pit reinstatement.

[Remark: If suitable electro-fusion step coupler is available for connecting the PE lining and the standard PE stub flange directly, expansion of the projected lining is not required. With unfavourable working condition (e.g. under wet and dirty environment), or with the need for speeding up the repair process, suitable proprietary flange adaptor for connecting the projected lining and the replacement pipe can be considered.]

CIPP

Step 1: Preparatory Work

Identify the exact location of the damaged rehabilitated pipe and excavate a temporary pit with sufficient size to facilitate the repair work.

Step 2: Removal of Damaged Lining

Minor damage to CIPP lining cannot be replaced using patches or mechanical repair clamp. Any damaged section must therefore be removed and replaced with a new replacement pipe. Use appropriate cutting tools (such as pipe saw, chain cutter, longitudinal pipe cutter, window cutter and/or radial cutter, depending on whether the host pipe is ductile or brittle) for cutting the host pipe and the damaged lining. Flame cutting is prohibited, in order to avoid causing any heat damage to the existing lining. The damaged section of the pipe including the host pipe and the lining is to be cut out. Once the section of the host pipe and the lining has been cut and removed, the lining must be cut back further to a sufficient length to facilitate the installation of the sealing system (see Step 8 for CIPP in Section 4.4.4).

Step 3: Installation of Replacement Pipe and Pit Reinstatement

Install the replacement pipe and the sealing system. See **Appendix 4.6** for detail. The replacement pipe should be concrete surrounded (if required), followed by backfilling and pit reinstatement.

Sliplining

Step 1: Preparatory Work

Identify the exact location of the damaged rehabilitated main, and excavate a temporary pit with sufficient size to facilitate the repair work.

Step 2: Removal of Damaged Lining

Use appropriate cutting tools (such as pipe saw, chain cutter, longitudinal pipe cutter, window cutter and/or radial cutter, depending on whether the host

pipe is ductile or brittle) for cutting the host pipe and the damaged lining. Flame cutting is prohibited, in order to avoid causing any heat damage to the existing lining. The damaged section of the pipe including the host pipe and the lining is to be cut out. The host pipe is carefully removed further with a circumferential cut to expose the cement (grouted) layer by using appropriate cutting tools for subsequent connection to electro-fusion couplers. Adjust the depth of cut to the minimum at the pipe cutter with reference to the thickness of the host pipe. Carefully hammer the host pipe to see if the cut section can be detached from the host pipe. Break off and remove the cement by carefully hammering to expose the lining.

Step 3: Installation of Replacement Pipe and Pit Reinstatement

Scrap the lining using scraper cylinder or hand pipe scrapers to remove the oxidised outer surface of the lining, if needed. Connect the exposed lining and the replacement pipe using standard electro-fusion coupler or proprietary flange adaptor. See **Appendix 4.3** for details. The exposed pipe should be concrete surrounded (if required), followed by backfilling and pit reinstatement.

Internal FRP Layer Lining

Step 1: Preparatory Work

Identify the exact location of the damaged rehabilitated pipe and excavate a temporary pit with sufficient size to facilitate the repair work. Weld a steel plate on the external surface of the pipe to seal up the damaged area. See **Appendix 4.7** for details.

Step 2: Temporary Repair of Damaged Lining

Determine the extent of the damaged lining and cut out the damaged area. Apply bitumen paint to cover the defect and the adjacent affected area in order to protect the host pipe against corrosion. Prepare two wide slots at both ends of the damaged lining. Install temporary sealing systems around the slots prepared. Backfill and reinstate the pit. Water supply can now be resumed temporarily.

Step 3: Permanent Repair of Damaged Lining

Permanent repair of damaged lining is to be carried out within three months of the pipe damage incident. The pipe is to be isolated and the whole section of the damaged lining between the wide slots formed should be removed. The hole/crack formed on the host pipe should be filled up by epoxy. For the reinstatement of internal FRP layer lining between the wide slots formed, refer to Step 3 for Internal FRP Layer Lining of Section 4.4.4 and **Appendix 4.7**. Sealing systems should be installed in each slot for bridging up the existing lining and the reinstated lining.

External FRP Layer Wrap

Step 1: Preparatory Work

Identify the exact location of the damaged rehabilitated pipe and excavate a temporary pit with sufficient size to facilitate the repair work if necessary. Weld a steel plate on the external surface of the pipe to seal up the damaged area temporarily. See **Appendix 4.8** for details.

Step 2: Permanent Repair of Damaged Wrap

Determine the extent of the damaged wrap. All wrap adjacent to the damaged pipe section is to be cut. For the reinstatement of external FRP layer, refer to Step 3 for External FRP Layer Wrap of Section 4.4.4 and **Appendix 4.8**. Allow for sufficient overlapping of wrap between the reinstated section and the existing undamaged section. Reinstall the sealing system if the end ring was removed during the reinstatement of external FRP layer wrap (see **Appendix 4.5** for details).

4.4.6 Possible Methods for Making Connection to Rehabilitated Water Mains

The methods for making connection to rehabilitated water mains have been consolidated from the submissions furnished by the contractors of recent R&R contracts, and are for general reference only. Engineers and inspectors are advised to refer to the operation and maintenance manual submitted by the contractor, together with the as-built drawings of the rehabilitated water mains for details.

Close Fit Lining

Step 1: Preparatory Work

Identify the location of the proposed new fitting to be made on the rehabilitated pipe and excavate a temporary pit with sufficient size to facilitate the connection work.

Step 2: Removal of Existing Lining

Use appropriate cutting tools (such as pipe saw, chain cutter, longitudinal pipe cutter, window cutter and/or radial cutter, depending on whether the host pipe is ductile or brittle) for cutting the host pipe and the existing lining. Flame cutting is prohibited, in order to avoid causing any heat damage to the existing lining. A section of the existing host pipe, together with the lining, is to be cut. The host pipe is then carefully removed further with a circumferential cut, leaving a section of lining projecting from the cut ends of the host pipe. The length of the cut should leave sufficient space for assembly of the electro-fusion couplers, and the depth of cut should be made to the minimum. Carefully hammer the host pipe to see if the cut section can be detached from the host pipe.

[Remark: The exposed lining installed previously by swaging should be clamped either by split-clamps or fusing tapping tee to prevent any possible reversion into the host pipe due to excess strain.]

Step 3: Installation of New Fitting and Pit Reinstatement

Expand the projected lining to the nearest PE pipe standard size and install a steel insert/support bush to the both ends of the exposed lining for ensuring the dimensional accuracy for subsequent electro-fusion to a stub flange. See **Appendix 4.3** for details. Use an industrial hairdryer to further soften the PE lining during the expansion process, if necessary. Scrap the lining using scraper cylinder or hand pipe scrapers to remove the oxidised outer surface of the lining, if needed. Connect the existing lining at the two projected ends with the new fittings. The new fittings installed should be concrete surrounded if required (wrapped with polythene sheet for debonding), followed by backfilling and pit reinstatement.

[Remark: Expansion of PE lining is not required if suitable electro-fusion step coupler is available. Proprietary flange adaptor can be used for connection. For the installation of tapping tee, it may be sufficient to cut a window on the host pipe to facilitate the installation of tapping tee by eletrofusion. It is however subject to the outside diameter of the close fit lining matches with the dimension of a standard tapping tee.]

CIPP

Step 1: Preparatory Work

Identify the location of the proposed new fitting to be made on the rehabilitated pipe and excavate a temporary pit with sufficient size to facilitate the connection work.

Step 2: Removal of Existing Lining

Use appropriate cutting tools (such as pipe saw, chain cutter, longitudinal pipe cutter, window cutter and/or or radial cutter, depending on whether the host pipe is ductile or brittle) for cutting the host pipe and the existing lining. Flame cutting is prohibited, in order to avoid causing any heat damage to the existing lining. A section of the pipe, including the host pipe and the lining, is to be cut out. Once the section of the host pipe and the lining has been cut and removed, the lining must be cut back further to a sufficient length to facilitate the installation of the sealing system (see Step 8 for CIPP in Section 4.4.4).

Step 3: Installation of New Fittings and Pit Reinstatement

Install the sealing system and the new fitting. See **Appendix 4.4** for detail. The new fitting should be concrete surrounded (if required), followed by backfilling and pit reinstatement.

Sliplining

Step 1: Preparatory Work

Identify the location of the proposed new fitting to be made on the rehabilitated pipe, and excavate a temporary pit with sufficient size to facilitate the connection work.

Step 2: Removal of Lining

Use appropriate cutting tools (such as pipe saw, chain cutter, longitudinal pipe cutter, window cutter and/or radial cutter, depending on whether the host pipe is ductile or brittle) for cutting the host pipe and the existing lining. Flame cutting is prohibited, in order to avoid causing any heat damage to the existing lining. A section of the pipe, including the host pipe and the lining, is to be cut out. The host pipe is carefully removed further with a circumferential cut to expose the cement (grouted) layer by using appropriate cutting tools, for subsequent connection to electro-fusion couplers. Adjust the depth of cut to the minimum at the pipe cutter reference to the thickness of the host pipe thickness. Carefully hammer the host pipe to see if the cut section can be detached from the host pipe. Break off and remove the cement by carefully hammering to expose the lining.

Step 3: Installation of New Fittings and Pit Reinstatement

Scrap the lining using scraper cylinder or hand pipe scrapers to remove the oxidised outer surface of the lining, if needed. Connect the lining and the new fitting using standard electro-fusion coupler or proprietary flange adaptor. See **Appendix 4.3** for details. The exposed pipe should be concrete surrounded if required (wrapped with polythene sheet for debonding), followed by backfilling and pit reinstatement.

Internal FRP Layer Lining

Step 1: Preparatory Work

Identify the location of the proposed new fitting to be made on the rehabilitated pipe and excavate a temporary pit with sufficient size to facilitate the connection work.

Step 2: Installation of Pre-fabricated Fitting

Cut a section of the existing rehabilitated pipe and connect the pre-fabricated fitting and the host pipe by welded steel collars. The internal FRP layer lining will be inevitably damaged by the heat generated during flame cutting and welding, and therefore repair of the damaged lining is required.

Step 3: Repair of Damaged Lining and Pit Reinstatement

Remove the damaged lining by grinding or disc cutting, leaving sufficient clearance away from the point of welding or flame cutting. Cut back the

existing lining so that straight edges are formed. Apply the epoxy coating on the surface exposed. Install sealing systems at the cut ends of lining, followed by backfilling and pit reinstatement. See **Appendix 4.9** for details.

External FRP Layer Wrap

Step 1: Preparatory Work

Identify the location of the proposed new fitting to be made on the rehabilitated pipe, excavate a pit with sufficient size as necessary and remove the existing external FRP layer wrap with adequate clearance from the location of the pre-fabricated fitting to be installed.

Step 2: Installation of Pre-fabricated Fitting

Cut a section of the existing rehabilitated pipe and connect the pre-fabricated fitting and the host pipe by welded steel collars. The external FRP layer wrap will be inevitably damaged by the heat generated during flame cutting and welding, and therefore removal of the damaged layer wrap is required.

Step 3: Installation of Sealing System and Pit Reinstatement

Apply the epoxy coating on the external surface of the host pipe exposed. Install the sealing systems at the cut ends of layer wrap, followed by backfilling and pit reinstatement as necessary. See **Appendices 4.5 and 4.10** for details.

JOINT UTILITY POLICY GROUP

Guideline for Orderly Disposition of Utilities Services

1. INTRODUCTION

- 1.1 It was decided in the JUPG Meeting dated 19th August 2004 to form a working group to reassess alternative means for utilities to share the limited underground space under footpath of new towns and if appropriate, existing built up area. The working group comprised the following members:

CLP Power Hong Kong Limited
Drainage Services Department
Highways Department
Hong Kong Broadband Network Limited
Hong Kong Cable Television Limited
Hutchison Global Communications Limited
New World Telecommunications Ltd.
PCCW-HKT Telephone Ltd.
The Hong Kong and China Gas Co., Ltd.
The Hongkong Electric Co., Ltd.
Towngas Telecommunications Fixed Network Limited
Water Supplies Department
Wharf T&T Limited

- 1.2 This guideline intends to promote a cooperative and accommodating culture among utility undertakers. It has no intention to alter utility undertakings' own design and construction standards. Wherever practicable, the "good practices" of this guideline should be applied to new utilities and to existing utilities when they are modified.

2. GUIDELINE FOR ORDERLY DISPOSITION OF UTILITIES SERVICES

2.1 Present Arrangement of Utilities

The current arrangement of utilities is as follows:

- a) HEC - The nominal depth was 760 mm for their LV cables and 900 mm for 22/11kV cables and associated communication cables in footpath. For carriageway, the minimum depth for LV, 22/11kV and associated communication cables was 900mm while the minimum depth for transmission cables at both footpath and carriageway was 1000 mm.
- b) HKCG - When site conditions permit gas pipes at footpath were normally installed at a minimum depth of 700 mm.
- c) PCCW-HKT - The nominal depth was 450mm for their cable ducts irrespective of the number of cable ducts in footway. Regarding the shafts of manholes, the nominal depths should be 1 m in footway and 1.5 m in carriageway respectively. Two shafts would be provided for a manhole under

normal circumstances. A table showing the dimensions of their typical jointing chambers is shown in Appendix 1.

- d) DSD - the link to their standard drawings is:
http://www.dsd.gov.hk/publications_publicity/other_publications/standard_drawings/index.htm
- e) WSD - The minimum depth requirements are 600 mm for footpath/verges/cycle tracks, and 1000 mm for carriageways.
The link to their standard drawings is:
http://www.wsd.gov.hk/en/html/info_publ/wsdstandard/volume1.htm
- f) HGC - The minimum depth of HGC's manhole shaft at footway was typically 1 m. The wall thickness of their joint box is less than 200 mm.
- g) CLP - The minimum cover from the surface of the footpath to the top of the services is 450 mm for LV cables and 750 mm for 11kV cables and associated communication cables. The minimum cover from the surface of the carriageway to the top of the services for LV/11kV and associated communication cables is 900 mm. The minimum depth for transmission cables at both footpath and carriageway is 1000 mm.

2.2 Means to Reduce the Overall Width Requirement

- a) Although the layering approach of directly burying utility services on top of one another to reduce the overall footpath width requirements has its advantages, it will not be further pursued for the time being as it is very difficult to resolve the obligations and costs for the removal and diversion of utility services among involved utility undertakings. Common Utility Enclosure (CUE) is technically a feasible form of layering approach for installations of different utility companies. However, CUE is more expensive than direct burying. The extra expenses can only be justified by its intangible benefits, which are highly controversial.
- b) There have been some cases where the project consultant for new development areas has coordinated with the telecom operators and appointed one of them to carry out duct laying work for the others. This mode of operation was beneficial to the parties concerned.

2.3 Provision of Transverse Corridor for Bulky Utilities / Structures

- a) Highways Department has made it explicit in their Structures Design Manual that the underground pile cap of Highways' structure would be constructed with a desirable minimum depth of 1.5 m from road surface to facilitate the installation of future utilities. All parties on bulky installation below road surface should follow the good example set by Highways Department.
- b) Water Supplies Department has reviewed the proposal to allow spare cable ducts in the thrust blocks and would not recommend such arrangement on operation and maintenance ground.

- c) As stormwater and sewerage flow by gravity, the locations and levels of stormwater and sewer pipes/culverts are governed by the hydraulics of the concerned flow path, it would be very difficult, if not impossible, for Drainage Services Department to adjust the locations and levels of existing pipes/culverts to accommodate subsequent underground installations. However, Drainage Services Department would review the feasibility of modification proposal on individual case basis.
- d) For new installations, DSD would not provide arbitrary traverse corridor or space (para. 2.4(b) refers) on their services as it affected the flow path and hydraulic gradient significantly leading to unjustified and uneconomical design. However, DSD welcomed UUs to offer comments during the planning or early design stage for making provisions for utilities services in the design of drainage structures on individual case basis. DSD reminded that other than DSD, government departments like CEDD, HyD, ArchSD, etc. would design and construct drainage structures and hence comments on drainage structures should be addressed to the responsible departments for timely consideration.
- e) For new installations, WSD would provide traverse corridor or space (para. 2.4 refers) on their services subject to technical feasibility and an economical design. WSD also welcomed UUs to offer comments during the planning or early design stage for making provisions for utilities services in the design of waterworks structures on case-by-case basis.

2.4 Considerations for Future Arrangements

- a) Wherever technically feasible, utility undertakings should consider maintaining more than the minimum depth required by the Conditions of Permit so as to accommodate other future utilities. For bulky installations such as body of underground chamber, underground pile cap of Highways' structure, base plate for bus-shelter, thrust block for pipes, utility undertakings should consider maintaining a minimum depth of 750 mm for footpath and 1200 mm for carriageway (Figure 1) so that one layer of utilities could go on top of the bulky installations and the minimum depth requirement required by the Conditions of Permit can also be maintained in order to prevent damage.

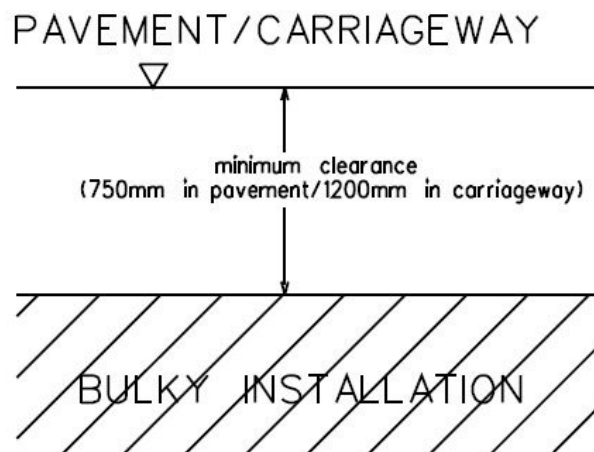

Figure 1

- b) If the minimum depths as mentioned in Section 2.4(a) cannot be maintained continuously in carriageway, whenever technical possible, utility undertakings should consider providing at localised areas with a minimum depth of 1200 mm for a minimum width of 1000 mm (Figure 2) at every interval of not more than 40 m, for other facilities to cross over.

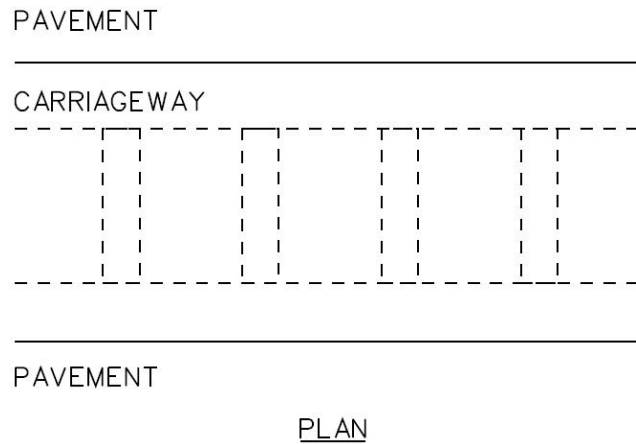

Figure 2 (a)

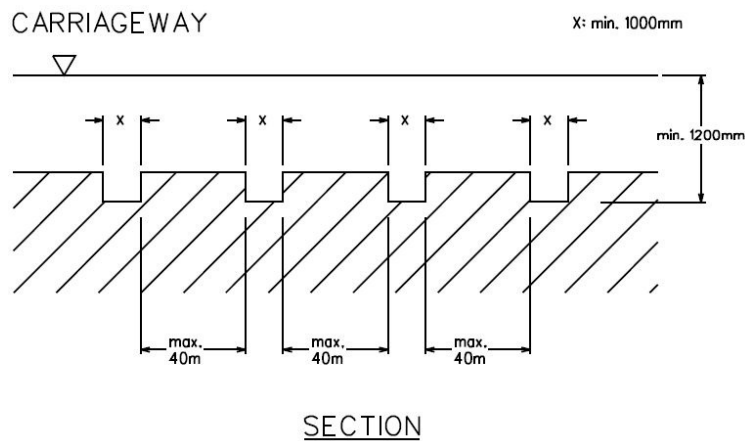

Figure 2 (b)

- c) Utilities should avoid laying facilities directly above the facilities of other utilities in order to prevent future conflicts or obstruction.
- d) To reduce unexpected obstruction encountered during excavation, underground facilities associated with those facilities seen at or above ground level should be restricted as far as practicable within the horizontal distance “X” of 200 mm from the horizontal boundary of the facilities seen at ground level (Figure 3) or above ground level (Figure 4) within the vertical depth “D” of 750 mm from the surface of pavement or 1200 mm from the surface of carriageway. For example, HEC has modified the design of a manhole shaft outside Bowen Road Garden car park to maintain the clearance of space from ground level to 1500 mm depth beyond 200 mm from the edges of the manhole cover. Please refer to Appendix 2 for the details.

- e) When the value of X exceeds 200 mm, means to indicate its value should be provided either (i) locally on the pit covers or (ii) as level 1 detail in response to EMPC enquiries. An example of EMPC response showing the dimension X (0.5 m) as level 1 detail is given in Appendix 3. The related information may be stored as DGN elements (i.e. pure graphic) in the Map Base. It will be converted to PDF format in generation of the EMPC Reply.

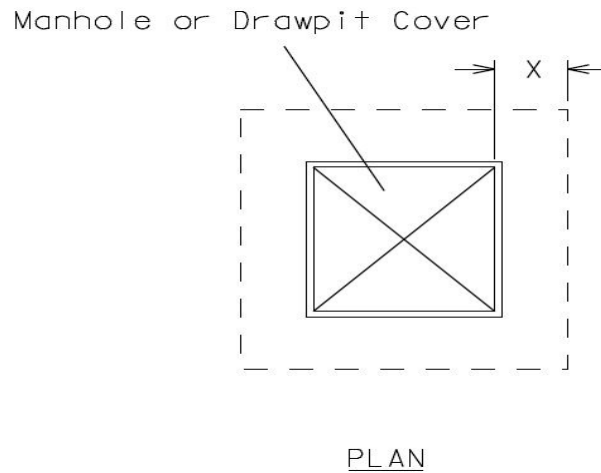

Figure 3 (a)

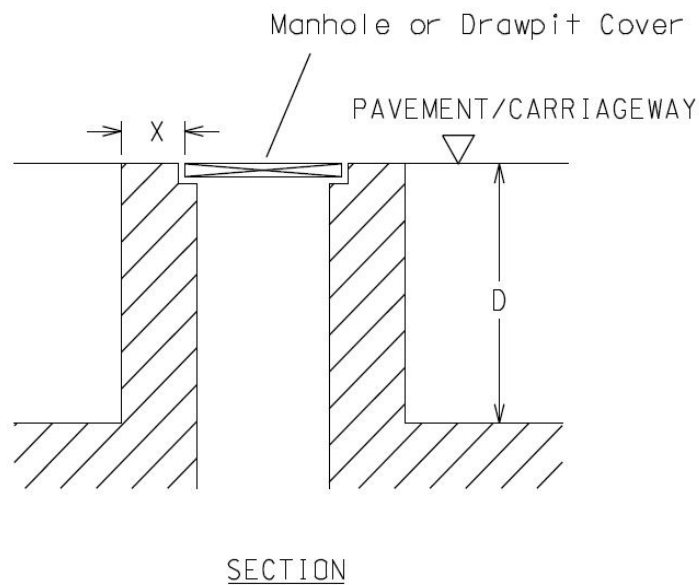
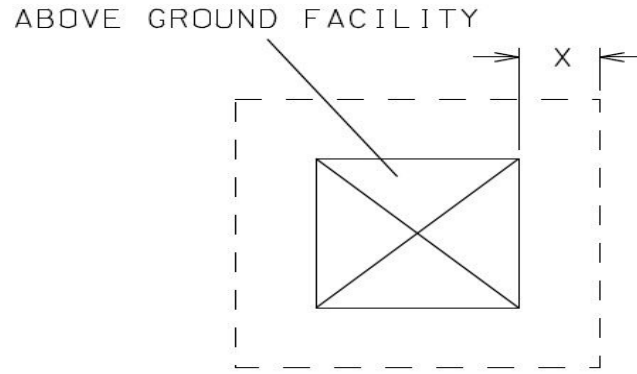
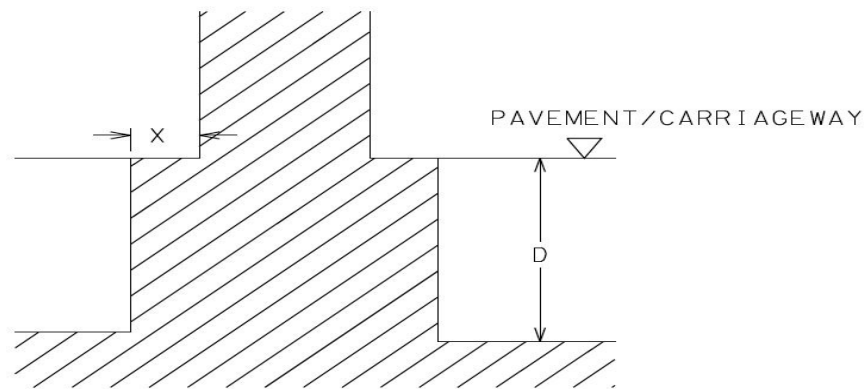

Figure 3 (b)



PLAN

Figure 4 (a)



SECTION

Figure 4 (b)

- f) Where installations occupy more than half the combined width of the non-carriageway, the minimum depth would be 900 mm, according to the Conditions of Permit issued by Highways Department.
- g) The areas around road junctions are usually the most critical. Bulky installations should be avoided at road junctions as far as practicable. The possibility of obtaining rights to install underground utilities within the set-back portion of buildings at road corners should be explored with Lands Department and Planning Department.

3. REVIEW OF THE GUIDELINE

When appropriate, JUPG will direct the review methodology and frequency of this practice guideline.

Remark: Please note that Appendices 1, 2 & 3 are not enclosed in the Manual of Mainlaying Practice, as the contents are not related to the design, construction and operation of water mains.

PRESSURE REDUCING VALVE CHAMBER

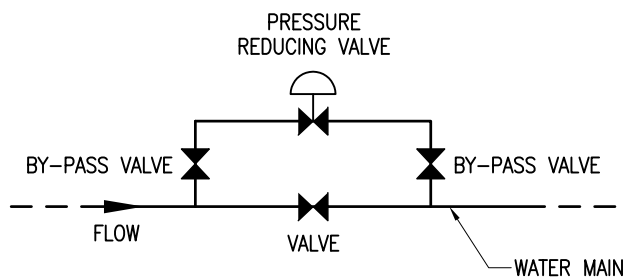
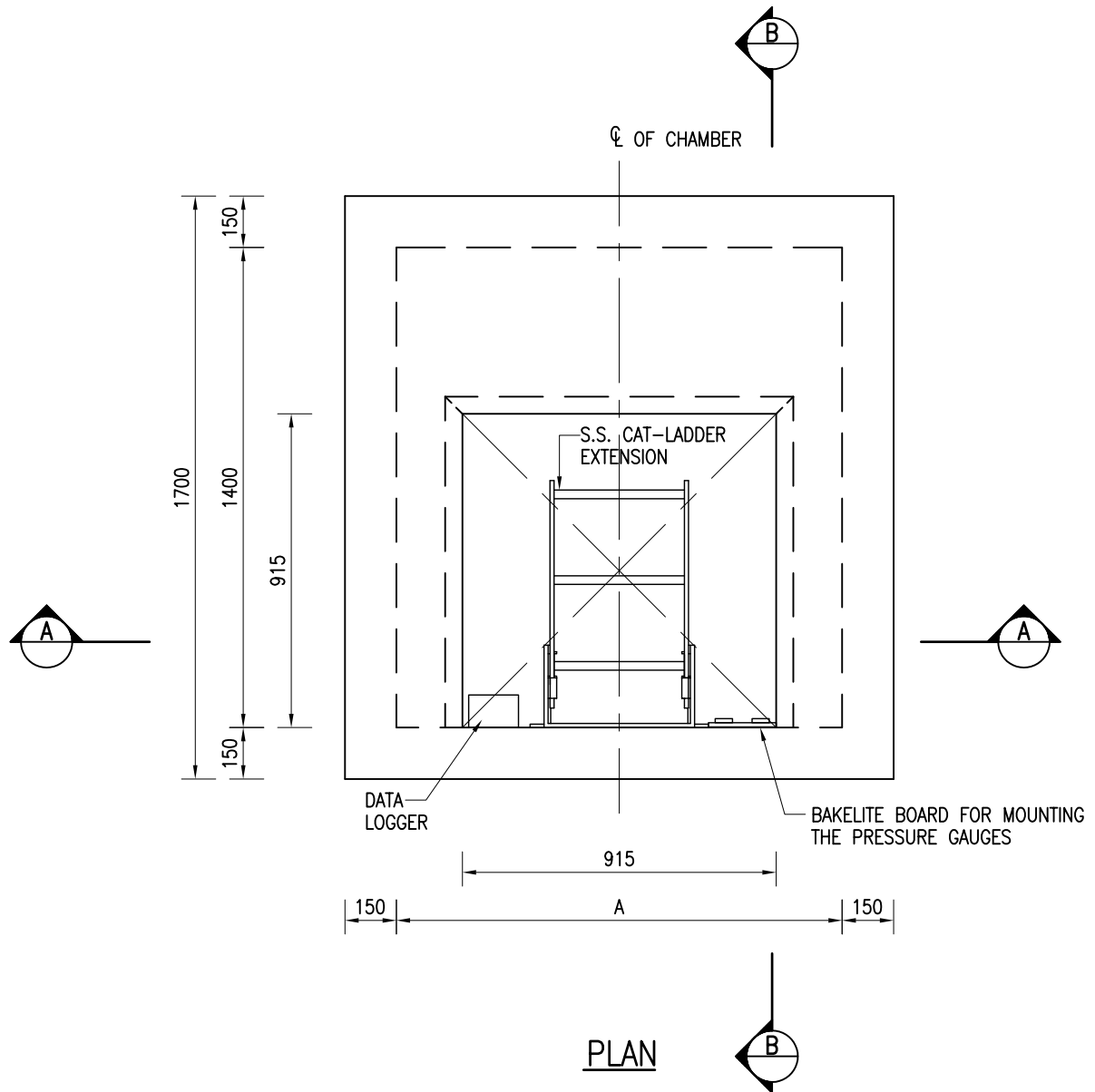

CONFIGURATION OF
PRESSURE REDUCING VALVE

PRESSURE REDUCING VALVE CHAMBER

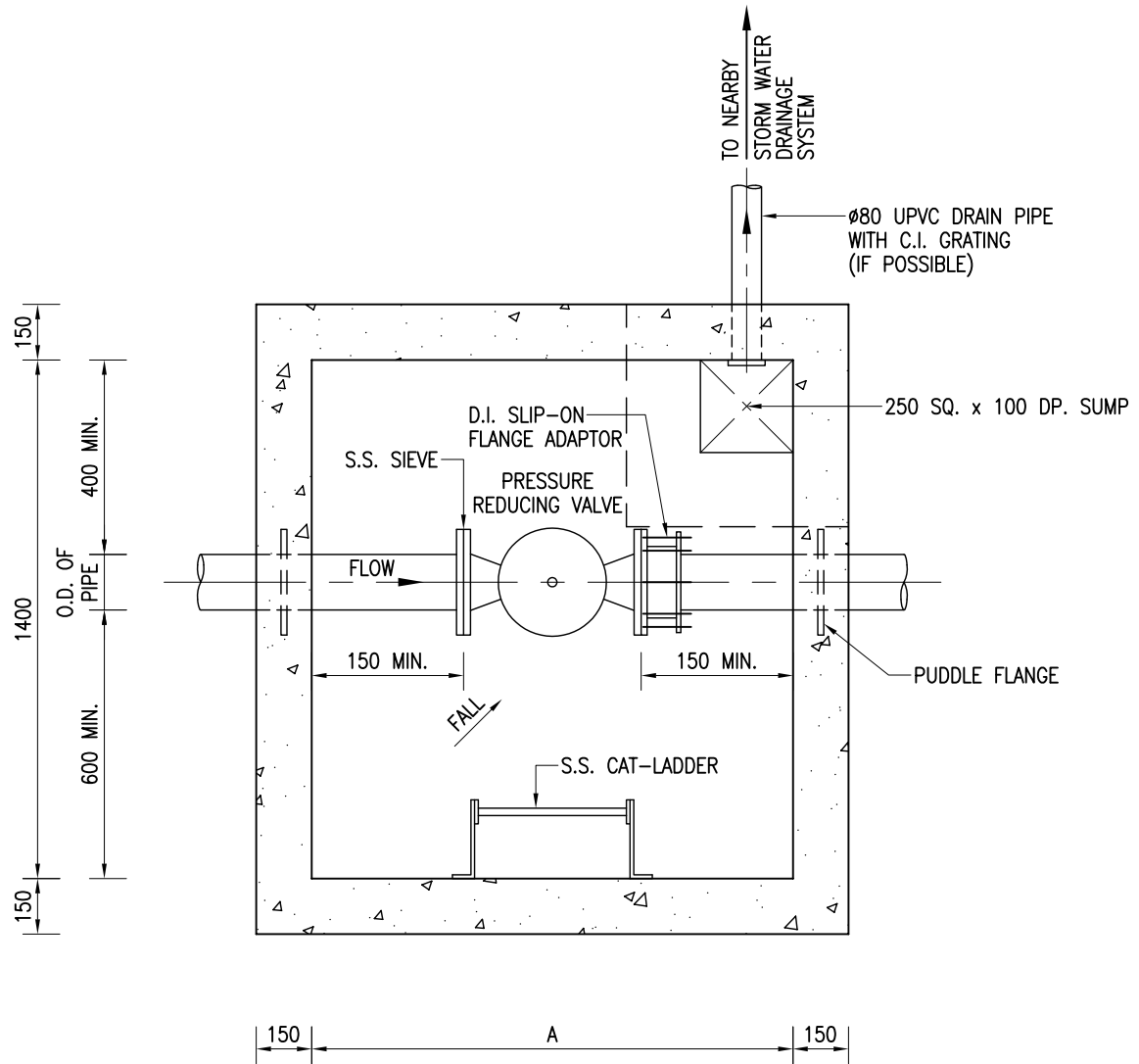

SECTIONAL PLAN

DIMENSIONS OF PRESSURE REDUCING VALVE CHAMBER (IN-LINE STRAINER CHAMBER SIMILAR)

NOMINAL DIA. OF PIPE (DN)	50	80	100	150	200	250	300
A (mm)	1100	1100	1200	1300	1300	1300	1400

PRESSURE REDUCING VALVE CHAMBER

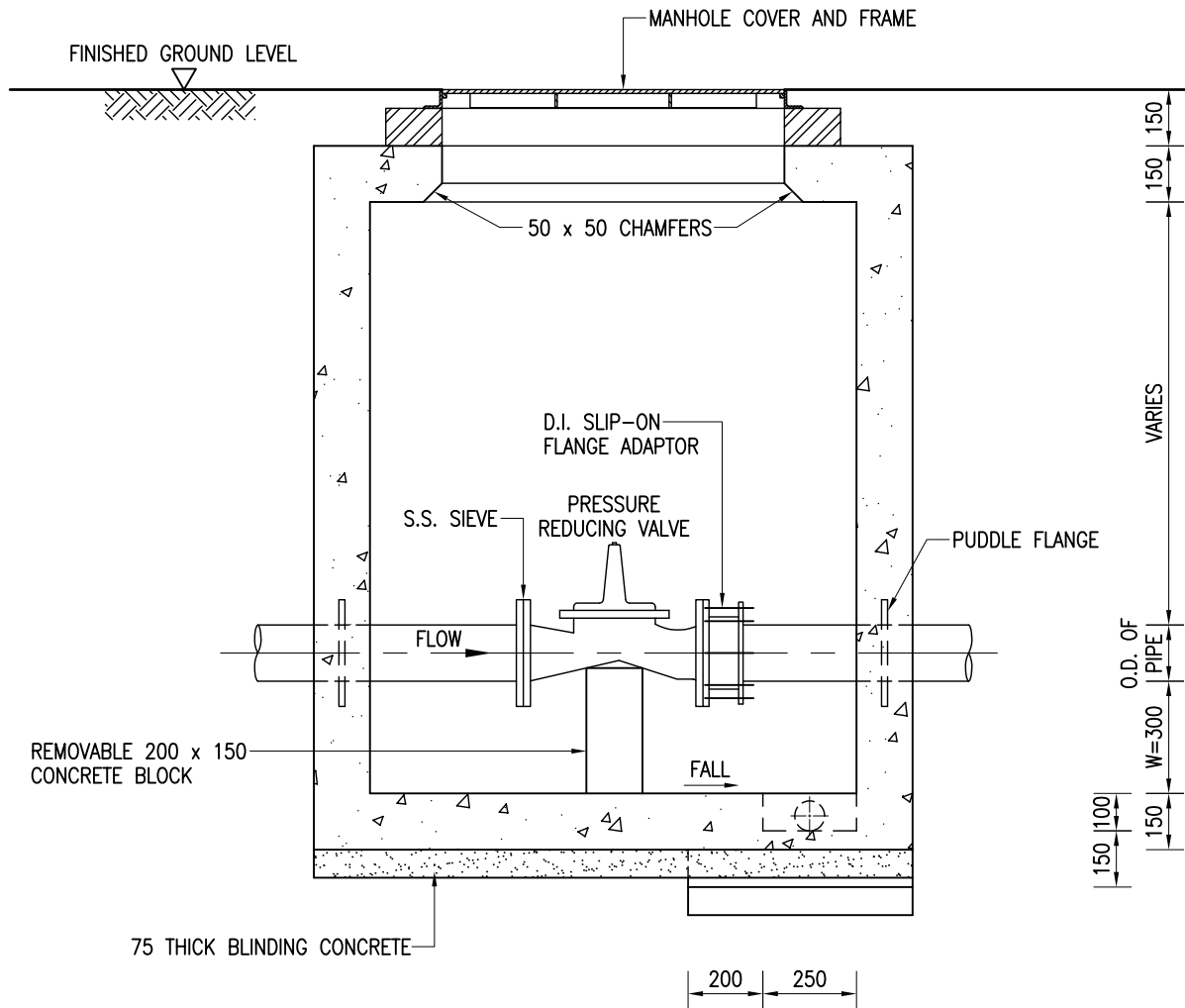

SECTION A - A

PRESSURE REDUCING VALVE CHAMBER

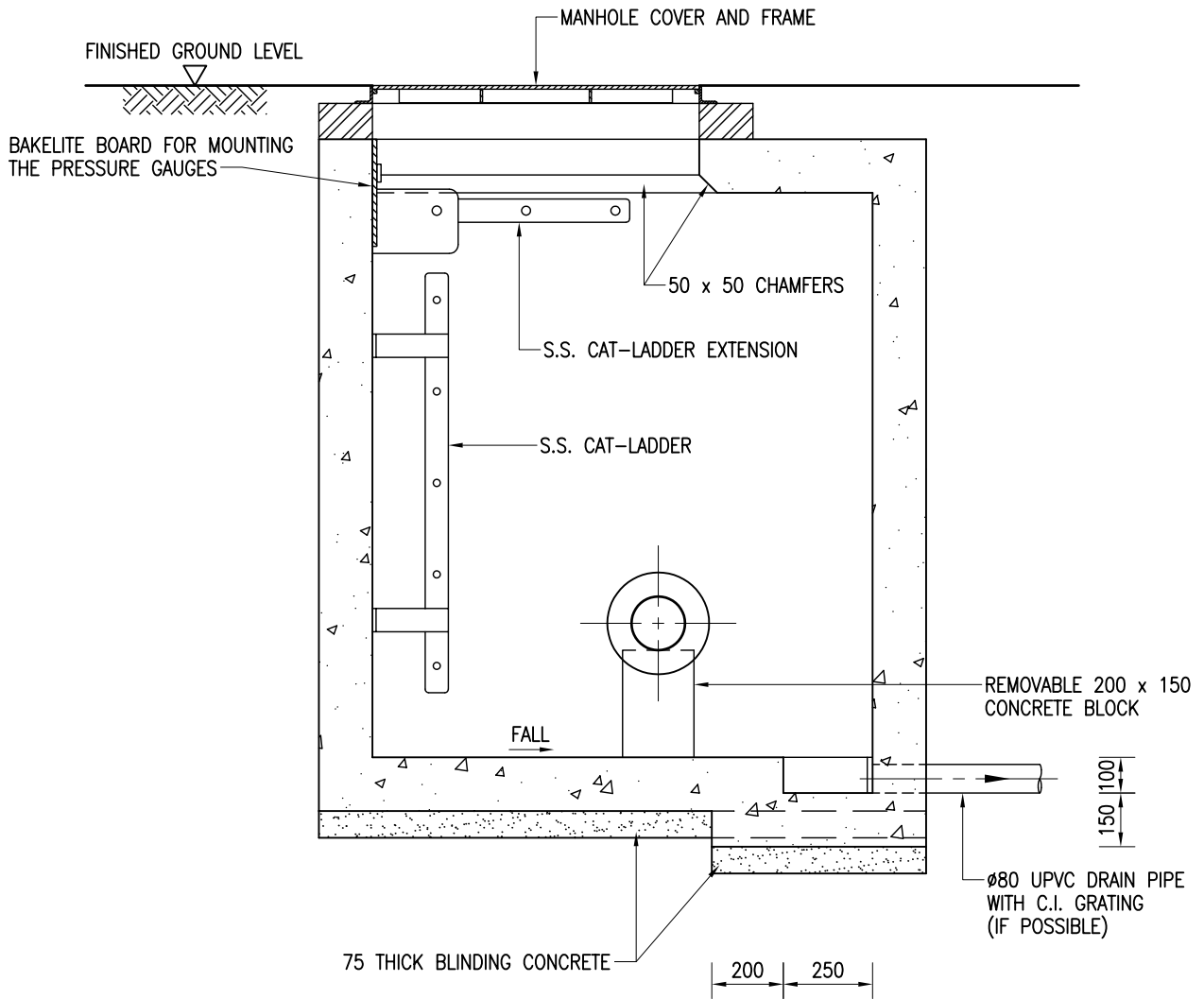

SECTION B - B

PRESSURE REDUCING VALVE CHAMBER

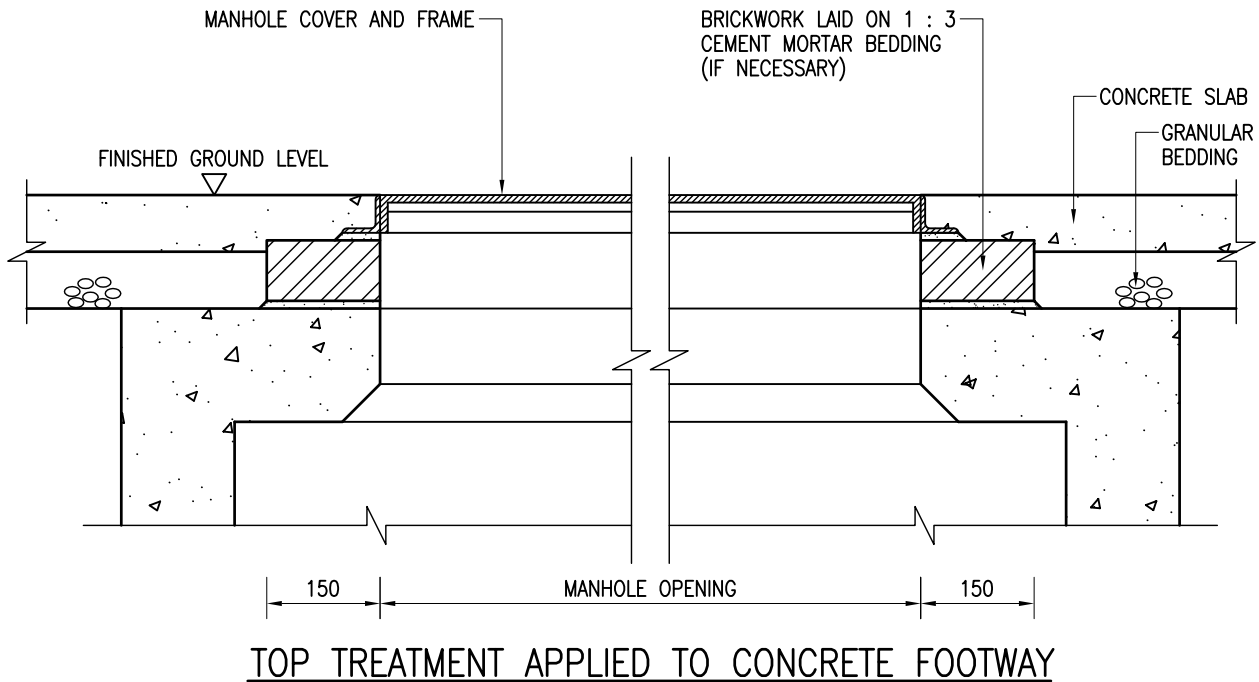

NOTES :

1. ALL DIMENSIONS ARE IN MILLIMETRES.
2. THE CHAMBER SHALL BE SITED ON FOOTWAY OR VERGE AREA TO AVOID TRAFFIC AND ON A BY-PASS PIPE BRANCHED OFF FROM THE MAIN PIPE.
3. THE CENTRE-LINE OF THE PIPE WITHIN THE CHAMBER SHALL BE HORIZONTAL UNLESS OTHERWISE APPROVED BY THE ENGINEER.
4. CONCRETE TO CHAMBER SHALL BE GRADE 35/20D. BLINDING CONCRETE SHALL BE GRADE 20/20D. MINIMUM CONCRETE COVER TO REINFORCEMENT SHALL BE 40mm.
5. REINFORCEMENT SHALL BE CUT TO SUIT OPENINGS AND THE SUMP PIT. BENDING AND SCHEDULING OF BARS SHALL COMPLY WITH BS 4466. MINIMUM LAP LENGTH FOR HIGH YIELD DEFORMED BARS SHALL BE $34 \times$ DIAMETER OF THE SMALLER LAPPED BAR UNLESS OTHERWISE SPECIFIED. FOR SIZE OF PIPE OPENING EQUAL TO OR EXCEEDING 200mm, PIPE OPENING REINFORCEMENT SHALL BE PROVIDED IN ACCORDANCE WITH DRAWING NO. WSD 1.12. FOR DESCRIPTION OF REINFORCEMENT, REFER TO DRAWING NO. WSD 7.1.
6. A STAINLESS STEEL SIEVE WITH 2mm OPENINGS SHALL BE PROVIDED AT THE FLANGE JOINT ON THE UPSTREAM SIDE OF THE PRESSURE REDUCING VALVE.
7. TAPERS SHALL BE PROVIDED ALONG THE PIPE OUTSIDE THE CHAMBER IN CASE THE PIPE AND BY-PASS VALVE HAVE DIFFERENT SIZES.
8. DRAIN PIPE FOR CHAMBER SHALL BE PROVIDED UNLESS FOUND TO BE IMPOSSIBLE ON SITE. DISCHARGE POINT OF THE DRAIN PIPE SHALL BE DETERMINED ON SITE BY THE ENGINEER.
9. FOR DETAILS OF STAINLESS STEEL CAT-LADDER AND EXTENSION, REFER TO DRAWING NO. WSD 7.3.
10. FOR DETAILS OF CAST IRON GRATING, REFER TO DRAWING NO. WSD 1.41.
11. FOR DETAILS OF MANHOLE COVER AND FRAME, REFER TO DRAWING NO. WSD 7.15 IN CASE OF CONCRETE FOOTWAY AND DRAWING NO. WSD 7.51 IN CASE OF FOOTWAY WITH PAVING BLOCKS.
12. FOR TOP TREATMENT APPLIED TO MANHOLE COVER OTHER THAN TO CONCRETE FOOTWAY, REFER TO DRAWING NO. WSD 1.24.
13. DIMENSIONS OF THE CHAMBER SHALL BE ADJUSTED BY THE CONTRACTOR TO SUIT SITE CONDITIONS. SUCH ADJUSTMENT IN DIMENSIONS OF THE CHAMBER SHALL BE APPROVED BY THE ENGINEER.
14. DETAILS OF THE CHAMBER ARE ALSO APPLICABLE TO IN-LINE STRAINER CHAMBER EXCEPT THAT DIMENSION W SHALL BE ADJUSTED BY THE CONTRACTOR IN CASE Y-TYPE IN-LINE STRAINER IS TO BE INSTALLED. SUCH ADJUSTMENT SHALL BE APPROVED BY THE ENGINEER.
15. EXACT POSITIONS FOR MOUNTING THE DATA LOGGER AND BAKELITE BOARD ONTO THE WALL OF THE CHAMBER SHALL BE DETERMINED ON SITE BY THE ENGINEER.

ELECTROMAGNETIC FLOWMETER CHAMBER ON CARRIAGEWAY FOR PIPE SIZE DN300 OR BELOW

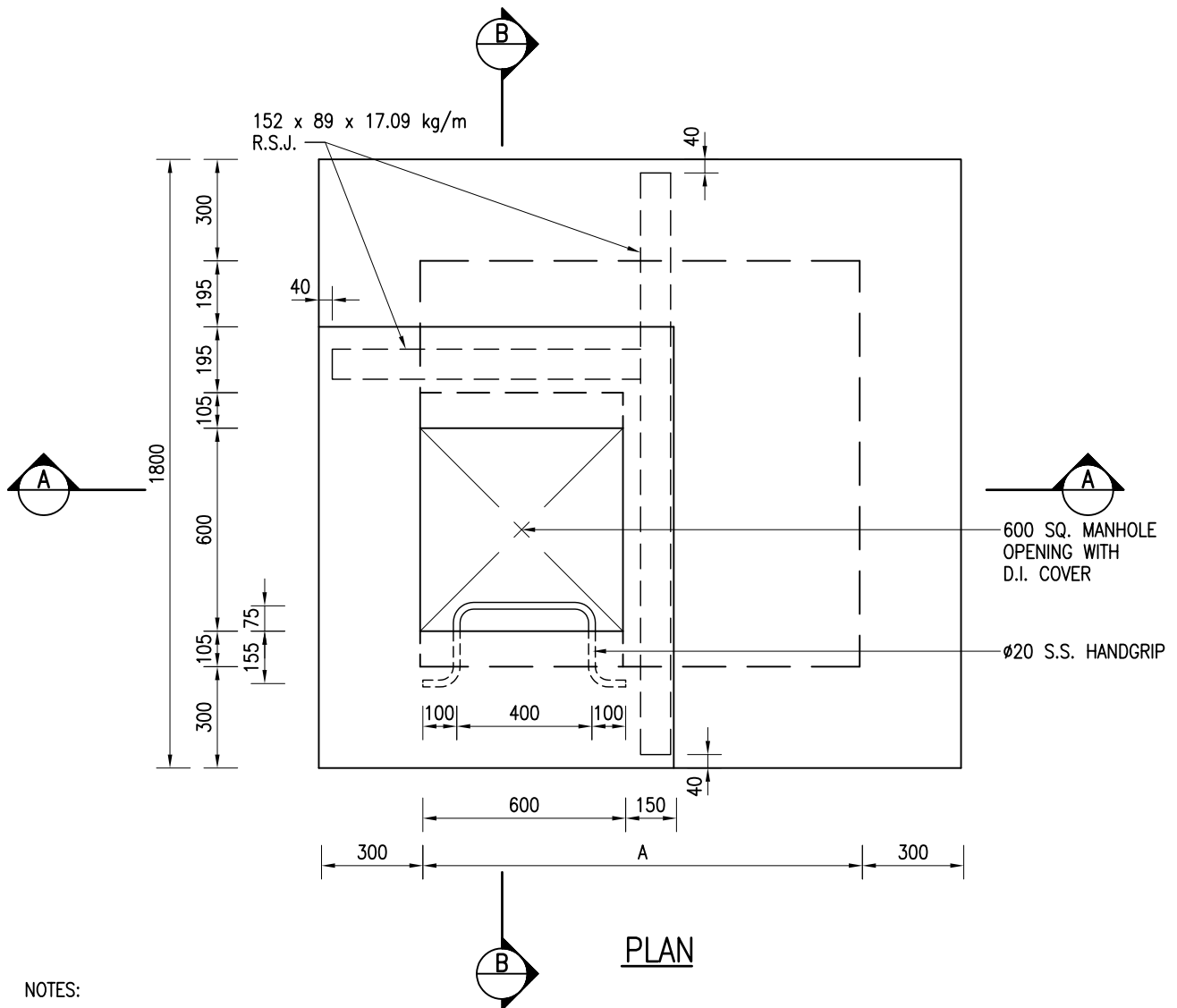

NOTES:

1. ALL DIMENSIONS ARE IN MILLIMETRES.
2. THE CENTRE-LINE OF THE PIPE WITHIN THE CHAMBER SHALL BE HORIZONTAL UNLESS OTHERWISE APPROVED BY THE ENGINEER.
3. CONCRETE TO CHAMBER SHALL BE GRADE 35/20D. BLINDING CONCRETE SHALL BE GRADE 20/20D. MINIMUM CONCRETE COVER TO REINFORCEMENT SHALL BE 40mm.
4. REINFORCEMENT SHALL BE CUT TO SUIT OPENINGS. BENDING AND SCHEDULING OF BARS SHALL COMPLY WITH BS 4466. MINIMUM LAP LENGTH FOR HIGH YIELD DEFORMED BARS SHALL BE 34 x DIAMETER OF THE SMALLER LAPPED BAR UNLESS OTHERWISE SPECIFIED. FOR SIZE OF PIPE OPENING EQUAL TO OR EXCEEDING 200mm, PIPE OPENING REINFORCEMENT SHALL BE PROVIDED IN ACCORDANCE WITH DRAWING NO. WSD 1.12. FOR DESCRIPTION OF REINFORCEMENT, REFER TO DRAWING NO. WSD 7.1.
5. A MINIMUM OF 5D STRAIGHT PIPE UPSTREAM AND 2D STRAIGHT PIPE DOWNSTREAM FOR ELECTROMAGNETIC FLOWMETER FROM THE END OF ELECTROMAGNETIC FLOWMETER SHALL BE PROVIDED WHERE D IS THE NOMINAL DIAMETER OF THE PIPE. THE DIMENSIONS 5D AND 2D SHALL BE ADJUSTED IN ACCORDANCE WITH THE RECOMMENDATION OF THE SUPPLIER OF THE FLOWMETER AND AGREED BY THE ENGINEER.
6. THE FLOWMETER SHALL BE A BATTERY-POWERED ELECTROMAGNETIC FLOWMETER UNLESS OTHERWISE AGREED BY THE ENGINEER.
7. TAPERS SHALL BE PROVIDED ALONG THE PIPE OUTSIDE THE CHAMBER IN CASE THE PIPE AND BY-PASS VALVE HAVE DIFFERENT SIZES.
8. DRAIN PIPE FOR CHAMBER SHALL BE PROVIDED UNLESS FOUND TO BE IMPOSSIBLE ON SITE. DISCHARGE POINT OF THE DRAIN PIPE SHALL BE DETERMINED ON SITE BY THE ENGINEER.
9. FOR DETAILS OF STAINLESS STEEL CAT-LADDER, REFER TO DRAWING NO. WSD 7.3.
10. FOR DETAILS OF CAST IRON GRATING, REFER TO DRAWING NO. WSD 1.41.
11. FOR DETAILS OF MANHOLE COVER, REFER TO DRAWING NO. WSD 7.48.
12. FOR DETAILS OF IDENTIFICATION TAPE FOR CABLE DUCT, REFER TO DRAWING NO. WSD 7.41.
13. FOR DETAILS OF IDENTIFICATION TYPE FOR WATER MAINS, REFER TO DRAWING NO. WSD 1.31.
14. FOR CONNECTION DETAILS OF ROLLED STEEL JOIST, REFER TO DRAWING NO. WSD 1.13.
15. FOR TOP TREATMENT APPLIED TO MANHOLE COVER, REFER TO DRAWING NO. WSD 1.24.
16. DIMENSIONS OF THE CHAMBER SHALL BE ADJUSTED BY THE CONTRACTOR TO SUIT SITE CONDITIONS. SUCH ADJUSTMENT IN DIMENSIONS OF THE CHAMBER SHALL BE APPROVED BY THE ENGINEER.

ELECTROMAGNETIC FLOWMETER CHAMBER ON CARRIAGEWAY FOR PIPE SIZE DN300 OR BELOW

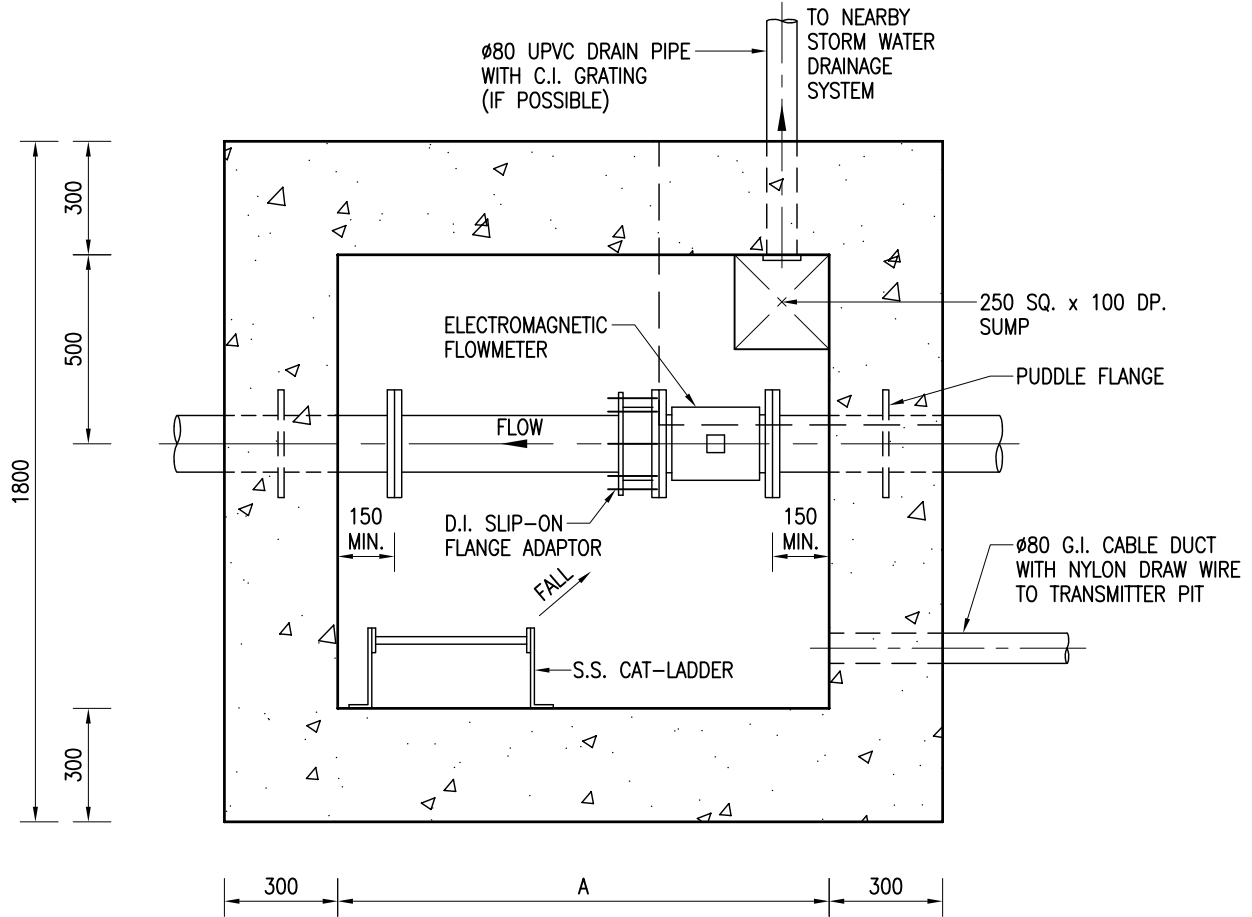

SECTIONAL PLAN

DIMENSIONS OF ELECTROMAGNETIC
FLOWMETER CHAMBER

NOMINAL DIA. OF PIPE (DN)	80	100	150	200	250	300
A (mm)	1100	1200	1300	1300	1300	1400

STANDARD MAINLAYING PRACTICE

APPENDIX 1.3
SHEET 3 of 4

ELECTROMAGNETIC FLOWMETER CHAMBER ON CARRIAGEWAY FOR PIPE SIZE DN300 OR BELOW

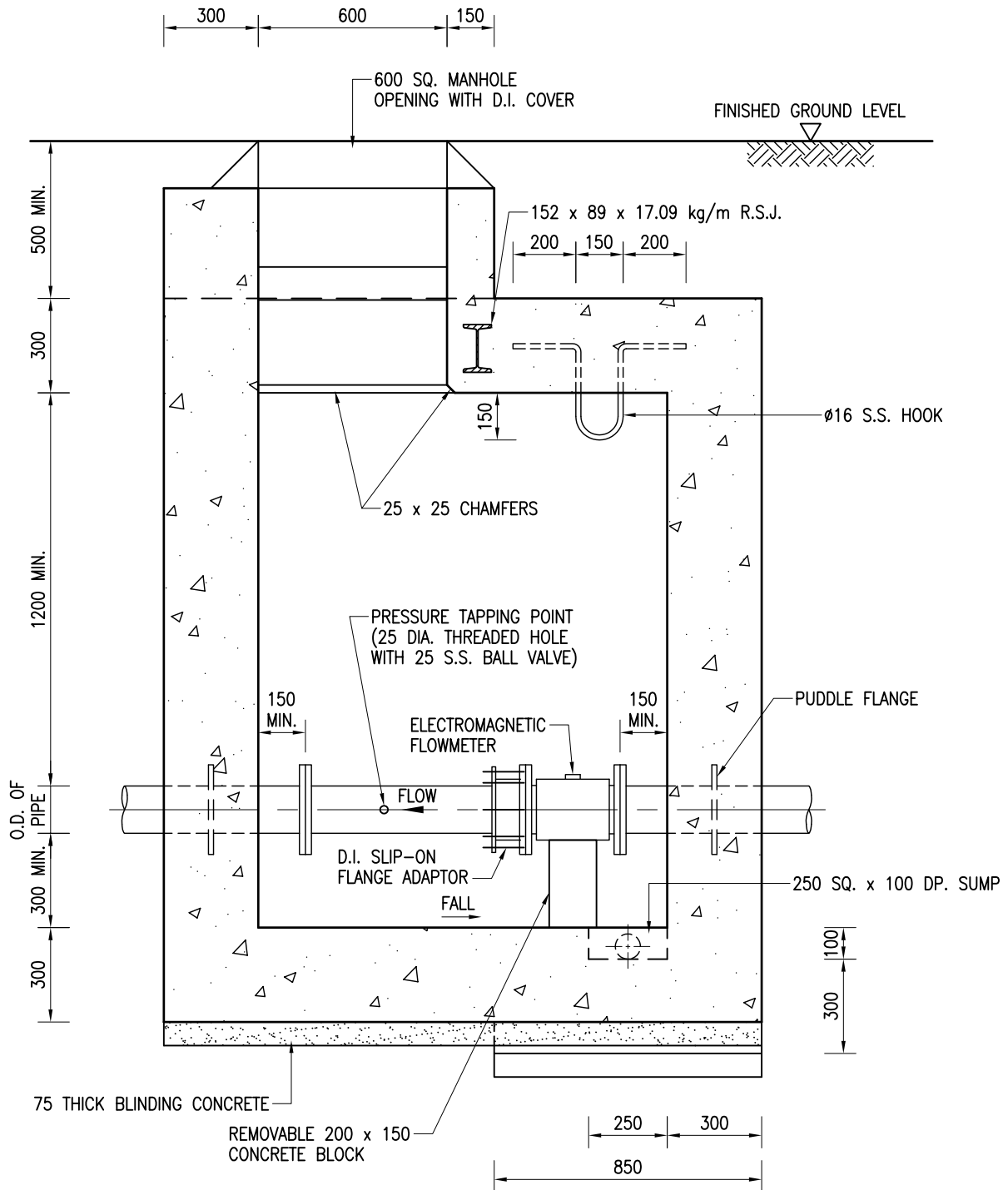

SECTION A - A

CAD REF. : AP010303.dwg



水務署
Water Supplies Department

STANDARD MAINLAYING PRACTICE

APPENDIX 1.3
SHEET 4 of 4

ELECTROMAGNETIC FLOWMETER CHAMBER ON CARRIAGEWAY FOR PIPE SIZE DN300 OR BELOW

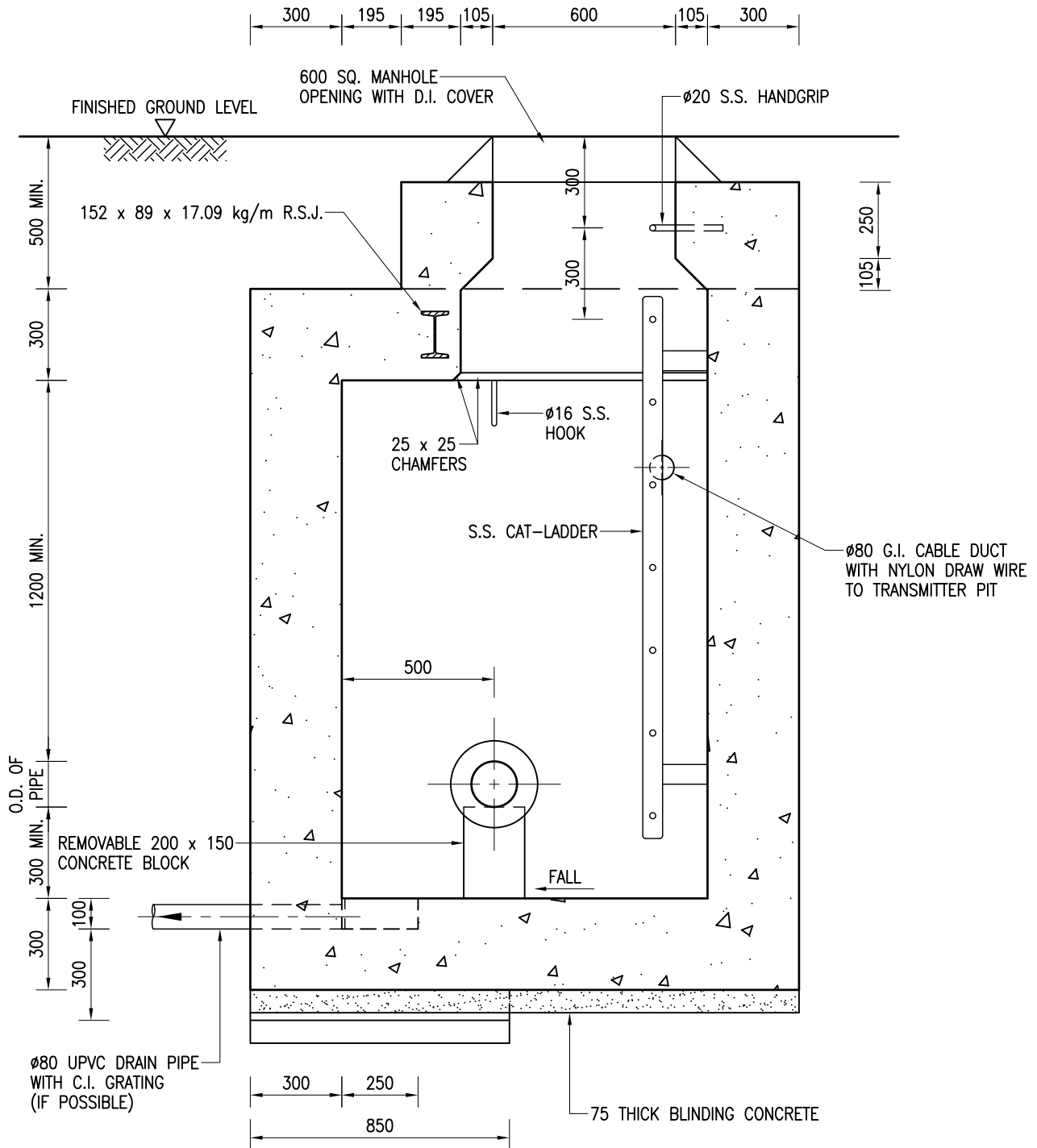

SECTION B - B

CAD REF. : AP010304.dwg



水務署
Water Supplies Department

TRANSMITTER PIT ON FOOTPATH

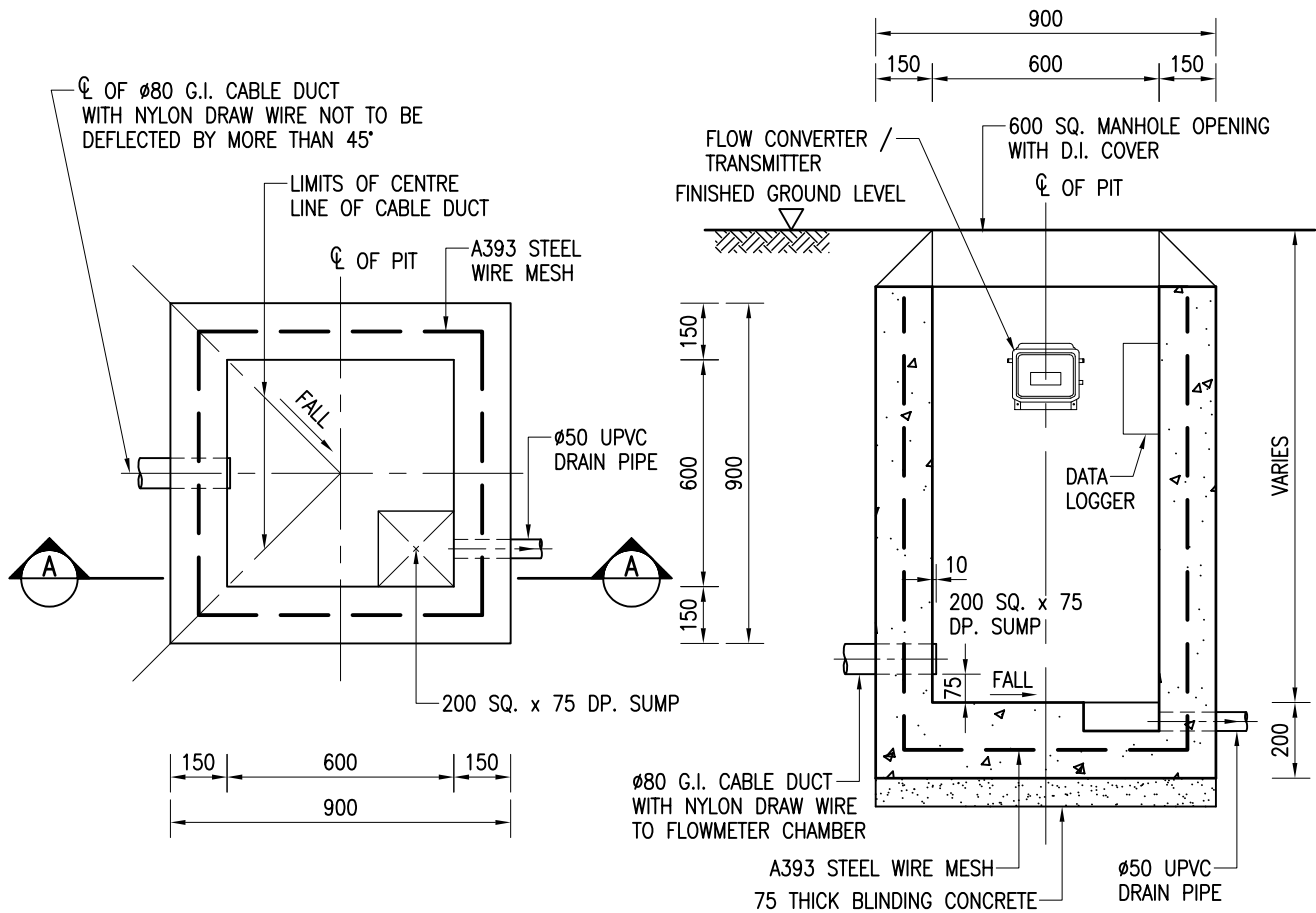

PLAN

STANDARD DETAILS

(COVER NOT SHOWN FOR CLARITY)

SECTION A - A

NOTES :

1. ALL DIMENSIONS ARE IN MILLIMETRES.
2. THE PIT SHALL BE SITED ON FOOTWAY OR PAVEMENT WITHOUT VEHICULAR TRAFFIC IN NORMAL CONDITION.
3. CONCRETE TO CHAMBER SHALL BE GRADE 35/20D. BLINDING CONCRETE SHALL BE GRADE 20/20D. MINIMUM CONCRETE COVER TO REINFORCEMENT SHALL BE 40mm.
4. STANDARD DETAILS SHALL BE FOLLOWED UNLESS OTHERWISE AGREED BY THE ENGINEER TO USE ALTERNATIVE DETAILS UNDER SPECIFIC CONDITIONS SUCH AS INADEQUATE SPACE ON SITE.
5. FOR DETAILS OF MANHOLE COVER, REFER TO DRAWING NO. WSD 7.48.
6. FOR DETAILS OF SURFACE BOX, REFER TO DRAWING NO. WSD 7.47.
7. DRAIN PIPE FOR PIT SHALL BE PROVIDED UNLESS FOUND TO BE IMPOSSIBLE ON SITE. DISCHARGE POINT OF THE DRAIN PIPE SHALL BE DETERMINED ON SITE BY THE ENGINEER.
8. THE FLOW CONVERTER/TRANSMITTER SHALL BE INSTALLED IN THE PIT AND CONNECTED TO THE FLOW DETECTOR HEAD OF THE FLOWMETER VIA A CABLE THROUGH THE CABLE DUCT.
9. FOR TOP TREATMENT APPLIED TO MANHOLE COVER, REFER TO DRAWING NO. WSD 1.24.
10. EXACT POSITIONS FOR MOUNTING THE FLOW CONVERTER/TRANSMITTER AND DATA LOGGER ONTO THE WALL OF THE PIT SHALL BE DETERMINED ON SITE BY THE ENGINEER.

ARRANGEMENT FOR BURIED ELECTROMAGNETIC FLOWMETER

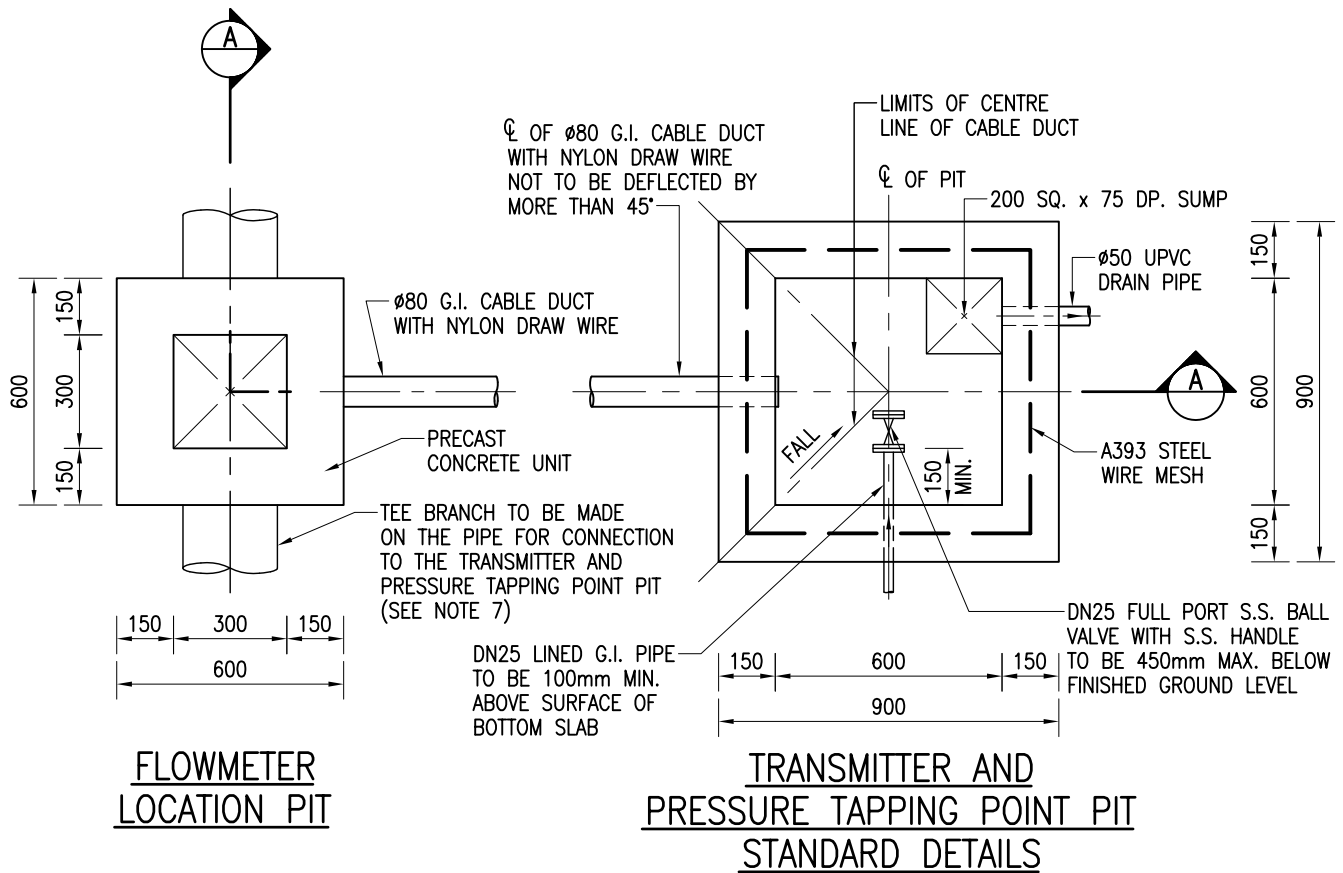

PLAN

(COVERS OF BOTH PITS NOT SHOWN FOR CLARITY)

NOTES :

1. ALL DIMENSIONS ARE IN MILLIMETRES.
2. THE PIT SHALL BE SITED ON FOOTWAY OR PAVEMENT WITHOUT VEHICULAR TRAFFIC IN NORMAL CONDITION.
3. CONCRETE TO CHAMBER SHALL BE GRADE 35/20D. BLINDING CONCRETE SHALL BE GRADE 20/20D. MINIMUM CONCRETE COVER TO REINFORCEMENT SHALL BE 40mm.
4. THE FLOW CONVERTER/TRANSMITTER SHALL BE INSTALLED IN THE TRANSMITTER AND PRESSURE TAPPING POINT PIT AND CONNECTED TO THE FLOW DETECTOR HEAD OF THE FLOWMETER VIA A CABLE THROUGH THE CABLE DUCT.
5. DRAIN PIPE FOR THE TRANSMITTER AND PRESSURE TAPPING POINT PIT SHALL BE PROVIDED UNLESS FOUND TO BE IMPOSSIBLE ON SITE. DISCHARGE POINT OF THE DRAIN PIPE SHALL BE DETERMINED ON SITE BY THE ENGINEER.
6. STANDARD DETAILS FOR THE TRANSMITTER AND PRESSURE TAPPING POINT PIT SHALL BE FOLLOWED UNLESS OTHERWISE AGREED BY THE ENGINEER TO USE ALTERNATIVE DETAILS UNDER SPECIFIC CONDITIONS SUCH AS INADEQUATE SPACE ON SITE. FOR ALTERNATIVE DETAILS OF TRANSMITTER AND PRESSURE TAPPING POINT PIT, REFER TO THE ALTERNATIVE DETAILS SHOWN ON APPENDIX 1.8.
7. FOR TYPICAL DETAILS OF THE CONNECTION BETWEEN THE PIPE AND THE TRANSMITTER AND PRESSURE TAPPING POINT PIT, REFER TO APPENDIX 1.8.
8. FOR DETAILS OF MANHOLE COVER, REFER TO DRAWING NO. WSD 7.48.
9. FOR DETAILS OF SURFACE BOX, REFER TO DRAWING NO. WSD 7.47.
10. FOR DETAILS OF PRECAST CONCRETE UNITS, REFER TO DRAWING NO. WSD 1.7.
11. FOR TOP TREATMENT APPLIED TO MANHOLE COVER, REFER TO DRAWING NO. WSD 1.24.
12. EXACT POSITIONS FOR MOUNTING THE FLOW CONVERTER/TRANSMITTER AND DATA LOGGER ONTO THE WALL OF THE PIT SHALL BE DETERMINED ON SITE BY THE ENGINEER.

ARRANGEMENT FOR BURIED ELECTROMAGNETIC FLOWMETER

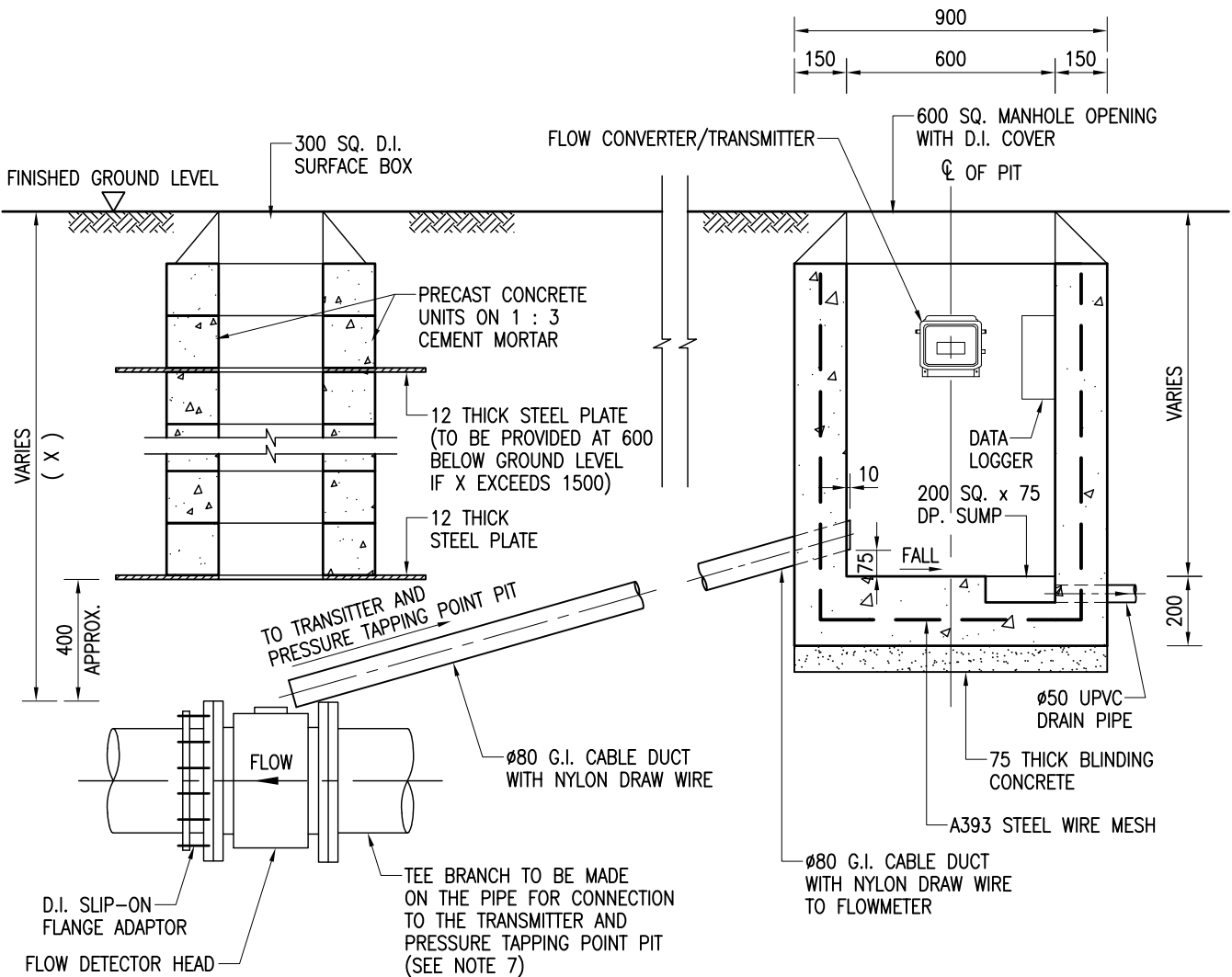

FLOWMETER LOCATION PIT

TRANSMITTER AND PRESSURE TAPPING POINT PIT
STANDARD DETAILS

SECTION A - A

STANDARD MAINLAYING PRACTICE

APPENDIX 1.6
SHEET 1 of 5

ELECTROMAGNETIC FLOWMETER AND PRESSURE REDUCING VALVE COMBINED CHAMBER

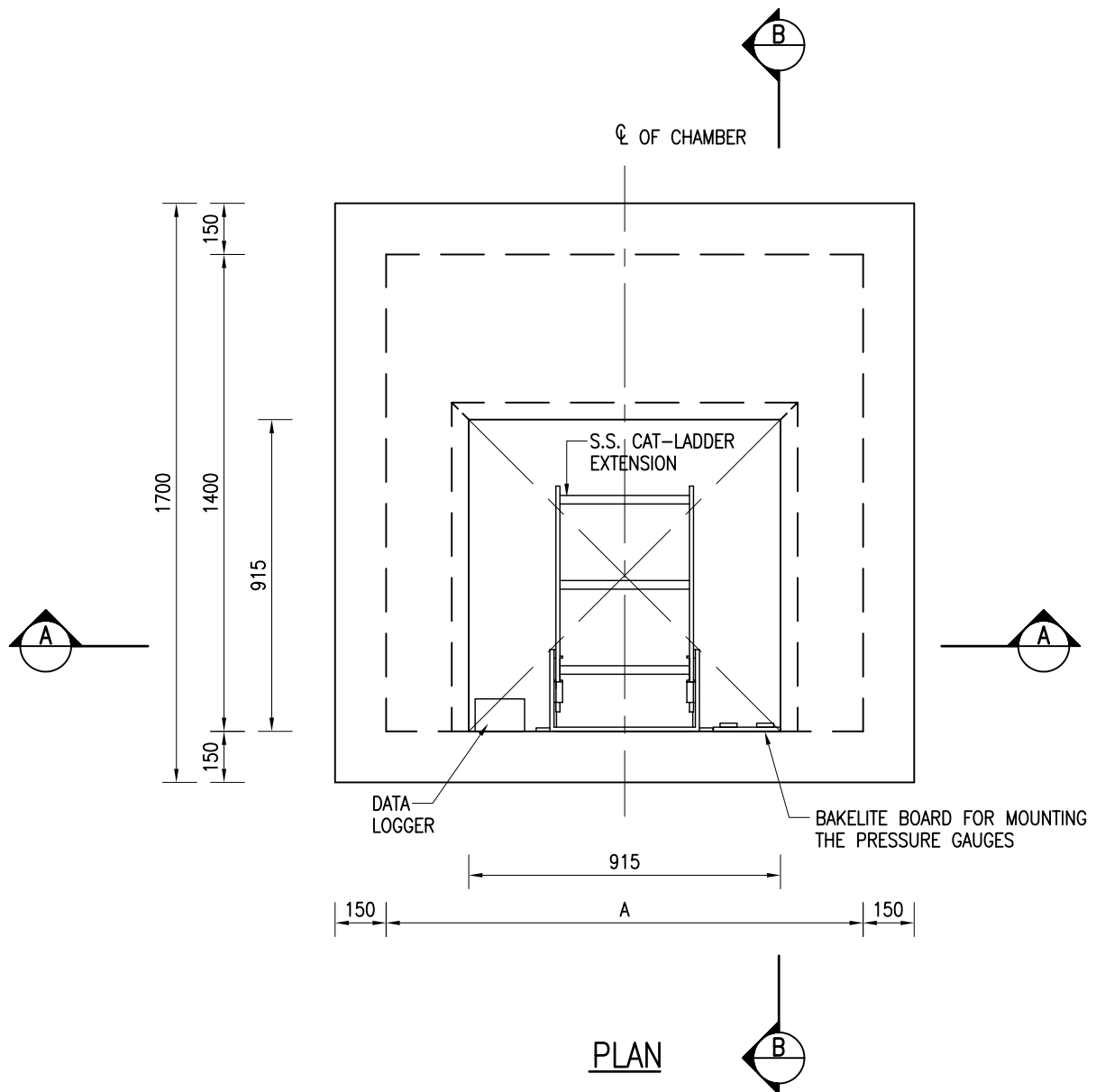

PLAN

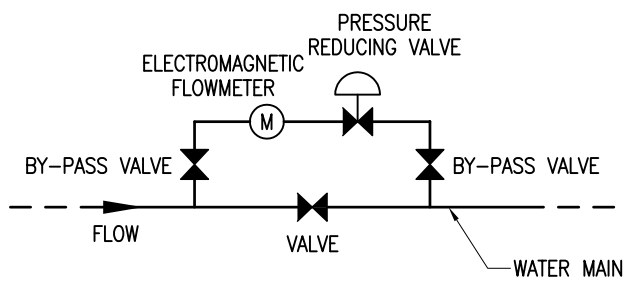

ARRANGEMENT OF FLOWMETER AND
PRESSURE REDUCING VALVE

CAD REF. : AP010601.dwg



水務署
Water Supplies Department

ELECTROMAGNETIC FLOWMETER AND PRESSURE REDUCING VALVE COMBINED CHAMBER

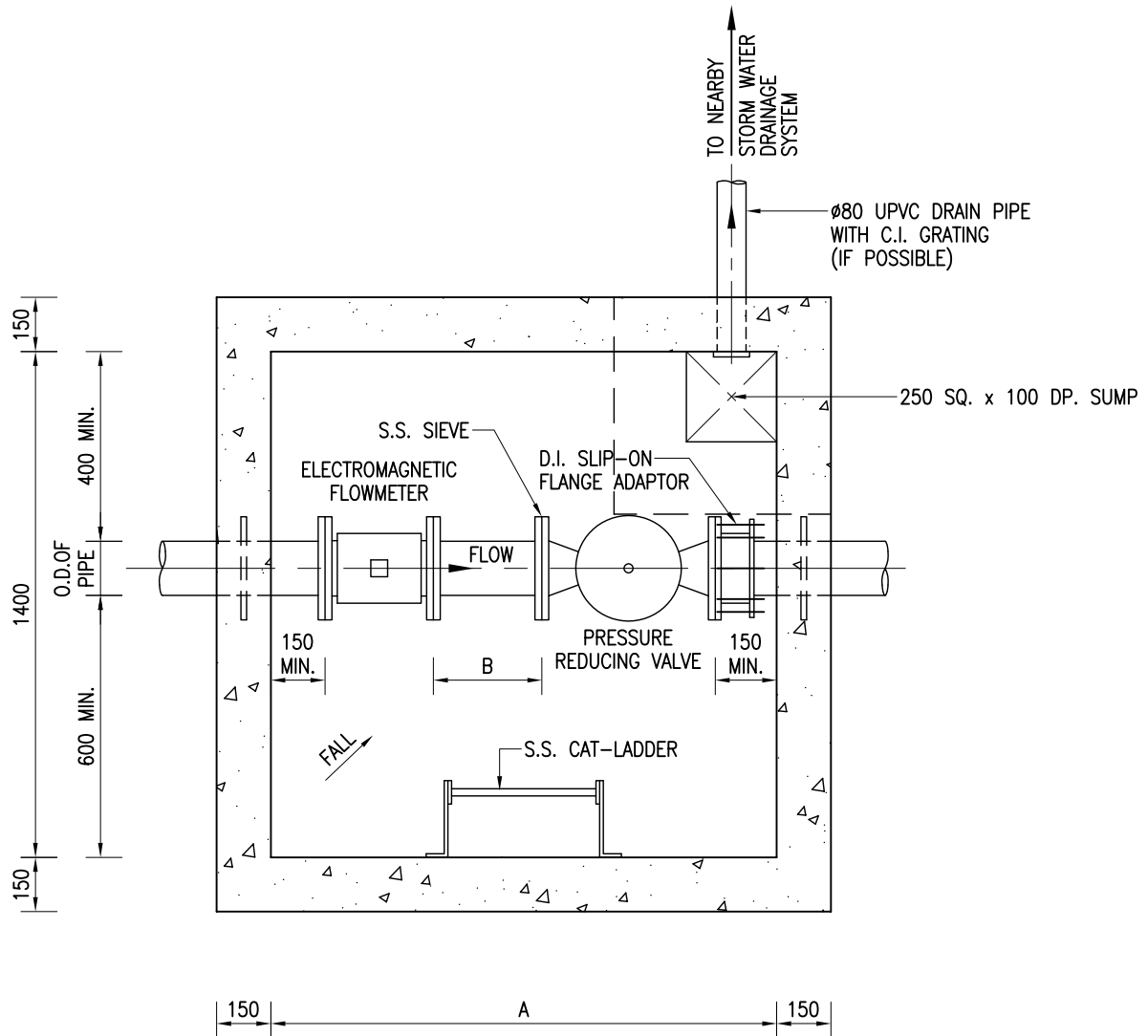

SECTIONAL PLAN

DIMENSIONS OF FLOWMETER AND PRESSURE REDUCING VALVE COMBINED CHAMBER

NOMINAL DIA. OF PIPE (DN)	80	100	150	200	250	300
A (mm)	1200	1250	1400	1700	2000	2300

STANDARD MAINLAYING PRACTICE

APPENDIX 1.6
SHEET 3 of 5

ELECTROMAGNETIC FLOWMETER AND PRESSURE REDUCING VALVE COMBINED CHAMBER

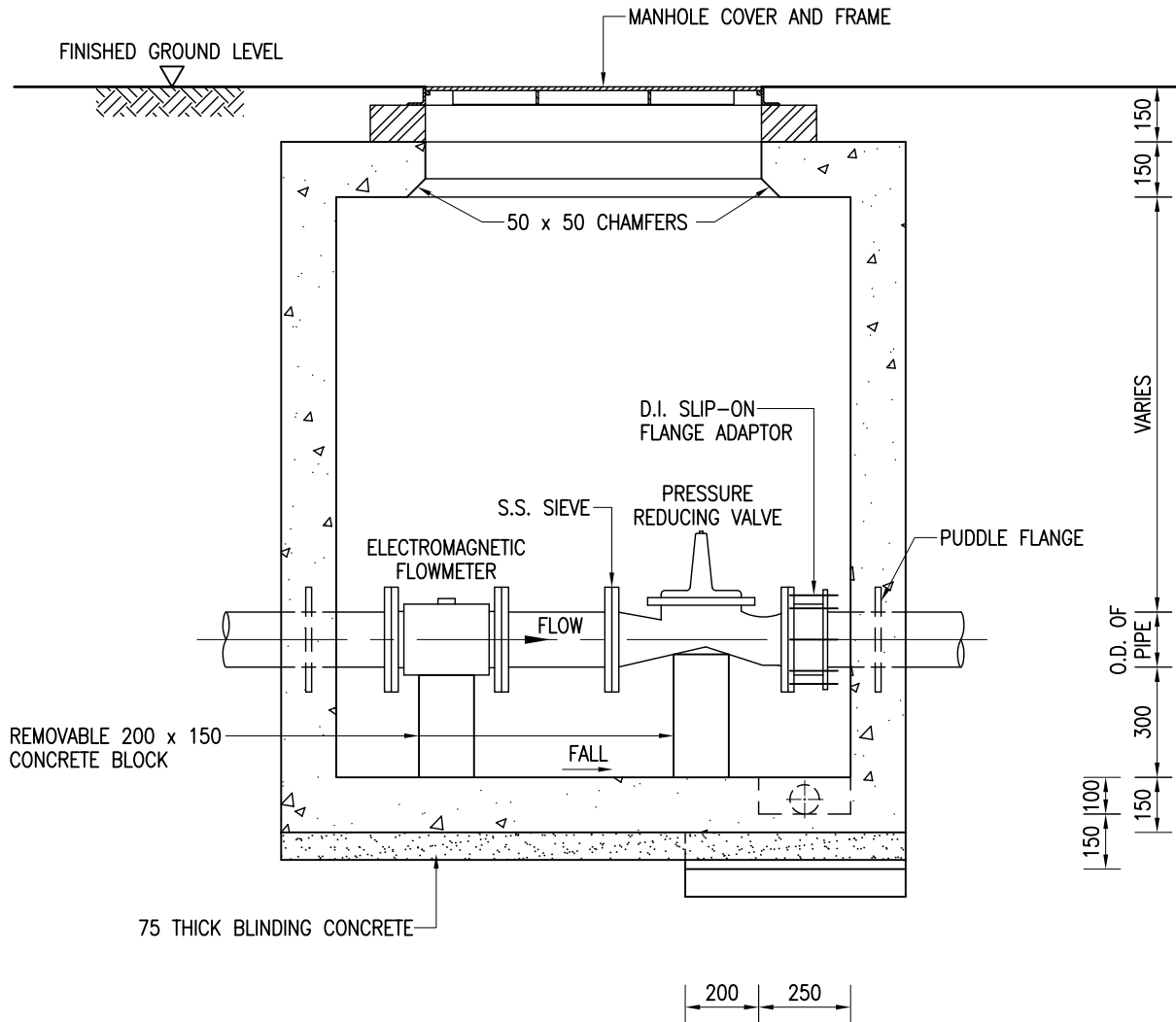

SECTION A - A

CAD REF. : AP010603.dwg



水務署
Water Supplies Department

ELECTROMAGNETIC FLOWMETER AND PRESSURE REDUCING VALVE COMBINED CHAMBER

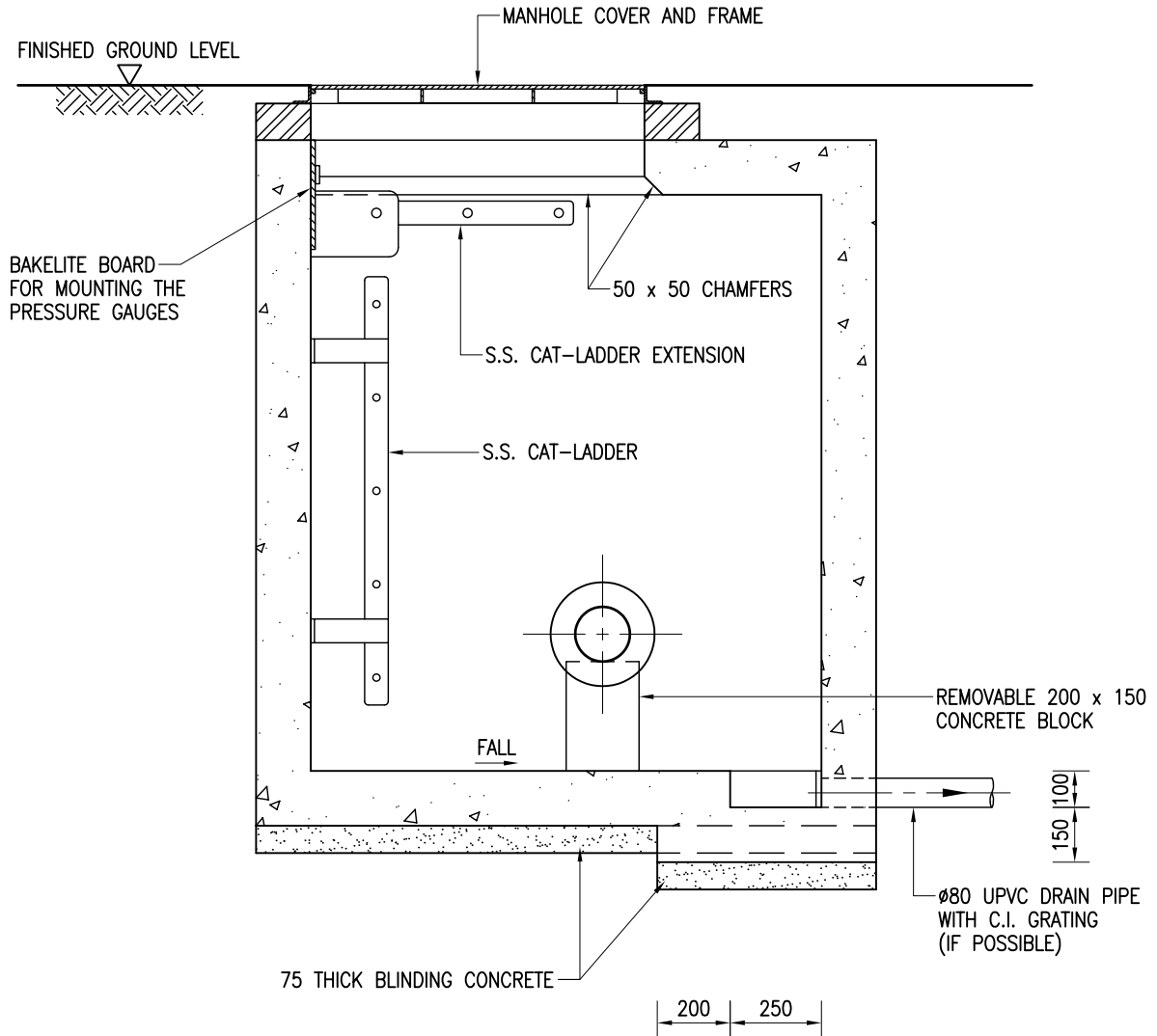

SECTION B - B

ELECTROMAGNETIC FLOWMETER AND PRESSURE REDUCING VALVE COMBINED CHAMBER

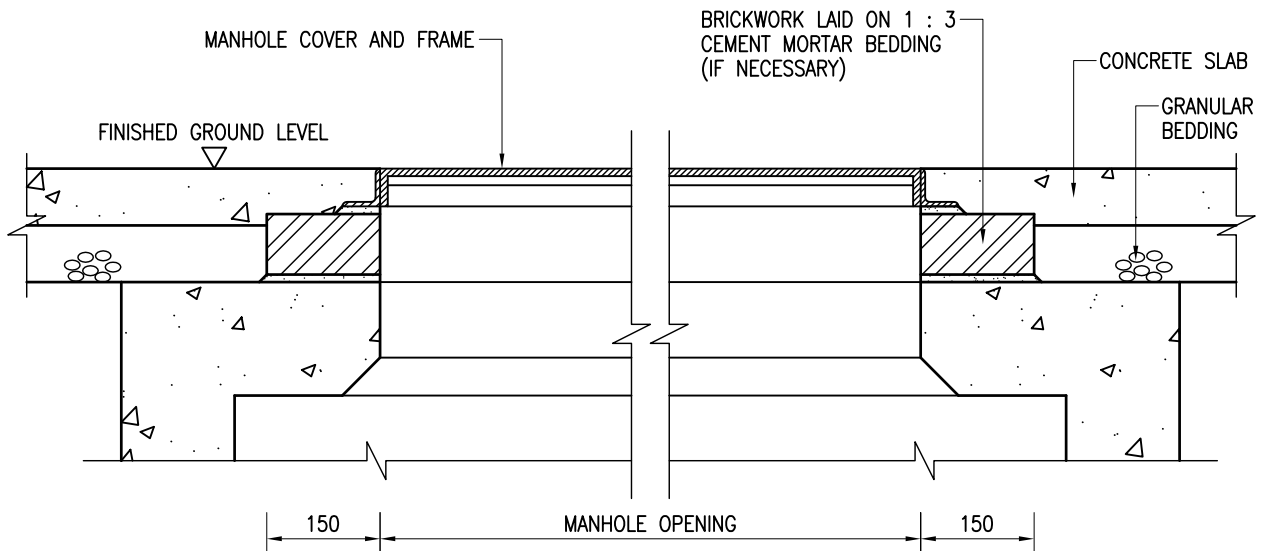

TOP TREATMENT APPLIED TO CONCRETE FOOTWAY

NOTES :

1. ALL DIMENSIONS ARE IN MILLIMETRES.
2. THE CHAMBER SHALL BE SITED ON FOOTWAY OR VERGE AREA TO AVOID TRAFFIC AND ON A BY-PASS PIPE BRANCHED OFF FROM THE MAIN PIPE.
3. THE CENTRE-LINE OF THE PIPE WITHIN THE CHAMBER SHALL BE HORIZONTAL UNLESS OTHERWISE APPROVED BY THE ENGINEER.
4. CONCRETE TO CHAMBER SHALL BE GRADE 35/20D. BLINDING CONCRETE SHALL BE GRADE 20/20D. MINIMUM CONCRETE COVER TO REINFORCEMENT SHALL BE 40mm.
5. REINFORCEMENT SHALL BE CUT TO SUIT OPENINGS AND THE SUMP PIT. BENDING AND SCHEDULING OF BARS SHALL COMPLY WITH BS 4466. MINIMUM LAP LENGTH FOR HIGH YIELD DEFORMED BARS SHALL BE $34 \times$ DIAMETER OF THE SMALLER LAPPED BAR UNLESS OTHERWISE SPECIFIED. FOR SIZE OF PIPE OPENING EQUAL TO OR EXCEEDING 200mm, PIPE OPENING REINFORCEMENT SHALL BE PROVIDED IN ACCORDANCE WITH DRAWING NO. WSD 1.12. FOR DESCRIPTION OF REINFORCEMENT, REFER TO DRAWING NO. WSD 7.1.
6. A MINIMUM OF 5D STRAIGHT PIPE UPSTREAM AND 2D STRAIGHT PIPE DOWNSTREAM FOR ELECTROMAGNETIC FLOWMETER FROM THE END OF ELECTROMAGNETIC FLOWMETER SHALL BE PROVIDED WHERE D IS THE NOMINAL DIAMETER OF THE PIPE. THE DIMENSIONS 5D AND 2D SHALL BE ADJUSTED IN ACCORDANCE WITH THE RECOMMENDATION OF THE SUPPLIER OF THE FLOWMETER AND AGREED BY THE ENGINEER.
7. THE FLOWMETER SHALL BE A BATTERY-POWERED ELECTROMAGNETIC FLOWMETER UNLESS OTHERWISE AGREED BY THE ENGINEER.
8. A STAINLESS STEEL SIEVE WITH 2mm OPENINGS SHALL BE PROVIDED AT THE FLANGE JOINT ON THE UPSTREAM SIDE OF THE PRESSURE REDUCING VALVE IN CASE AN IN-LINE STRAINER ALONG THE PIPE CANNOT BE INSTALLED ON THE UPSTREAM SIDE.
9. TAPERS SHALL BE PROVIDED ALONG THE PIPE OUTSIDE THE CHAMBER IN CASE THE PIPE AND BY-PASS VALVE HAVE DIFFERENT SIZES.
10. DRAIN PIPE FOR CHAMBER SHALL BE PROVIDED UNLESS FOUND TO BE IMPOSSIBLE ON SITE. DISCHARGE POINT OF THE DRAIN PIPE SHALL BE DETERMINED ON SITE BY THE ENGINEER.
11. FOR DETAILS OF STAINLESS STEEL CAT-LADDER AND EXTENSION, REFER TO DRAWING NO. WSD 7.3.
12. FOR DETAILS OF CAST IRON GRATING, REFER TO DRAWING NO. WSD 1.41.
13. FOR DETAILS OF MANHOLE COVER AND FRAME, REFER TO DRAWING NO. WSD 7.15 IN CASE OF CONCRETE FOOTWAY AND DRAWING NO. WSD 7.51 IN CASE OF FOOTWAY WITH PAVING BLOCKS.
14. FOR TOP TREATMENT APPLIED TO MANHOLE COVER OTHER THAN TO CONCRETE FOOTWAY, REFER TO DRAWING NO. WSD 1.24.
15. DIMENSION B SHALL NORMALLY BE $2 \times$ NOMINAL DIAMETER OF PIPE AND MAY BE REDUCED BY THE CONTRACTOR TO SUIT THE LENGTHS OF FLOWMETER AND PRESSURE REDUCING VALVE USED.
16. DIMENSIONS OF THE CHAMBER SHALL BE ADJUSTED BY THE CONTRACTOR TO SUIT SITE CONDITIONS. SUCH ADJUSTMENT IN DIMENSIONS OF THE CHAMBER SHALL BE APPROVED BY THE ENGINEER.
17. EXACT POSITIONS FOR MOUNTING THE DATA LOGGER AND BAKELITE BOARD ONTO THE WALL OF THE CHAMBER SHALL BE DETERMINED ON SITE BY THE ENGINEER.

ELECTROMAGNETIC FLOWMETER, PRESSURE REDUCING VALVE AND IN-LINE STRAINER COMBINED CHAMBER

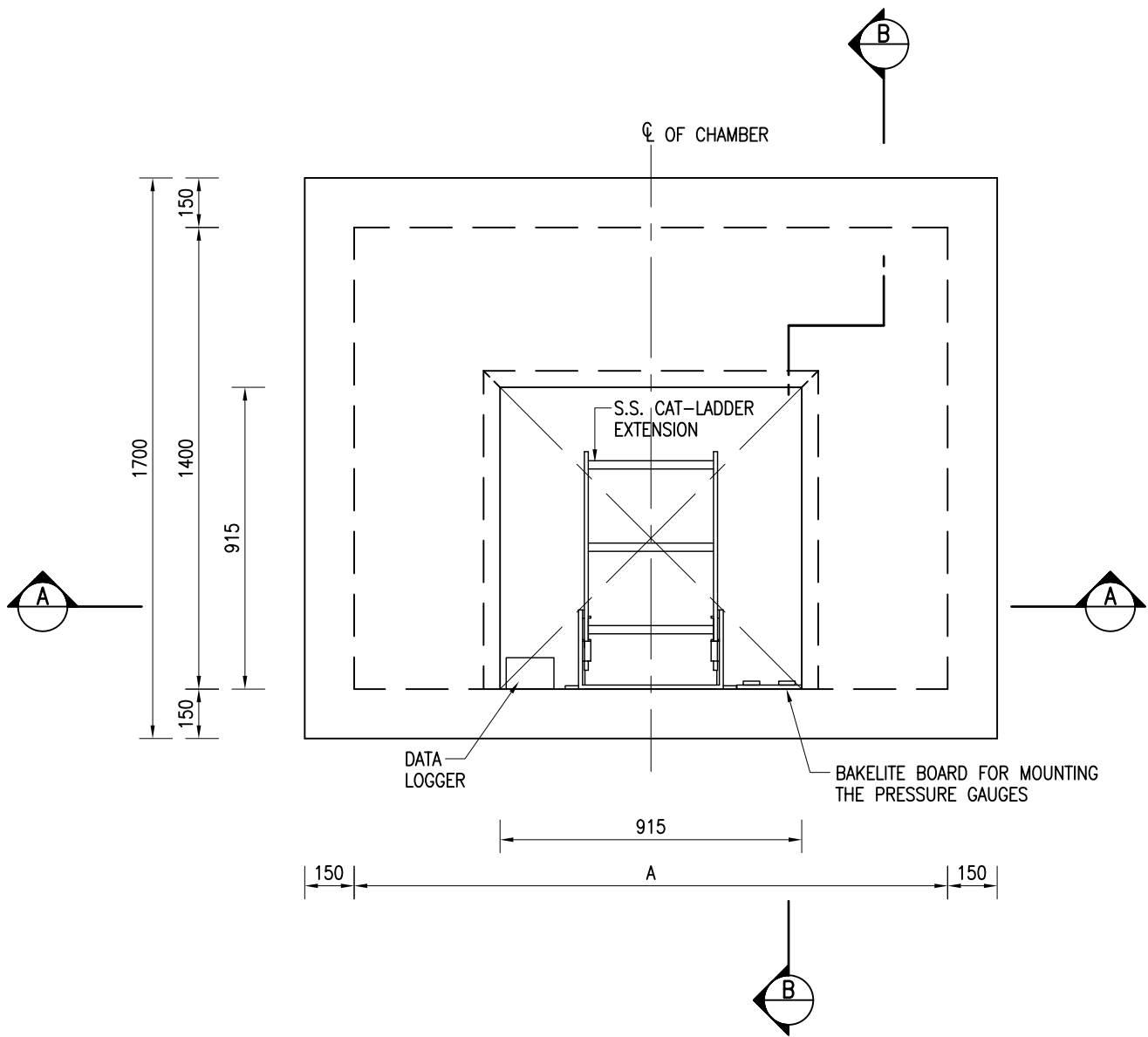

PLAN

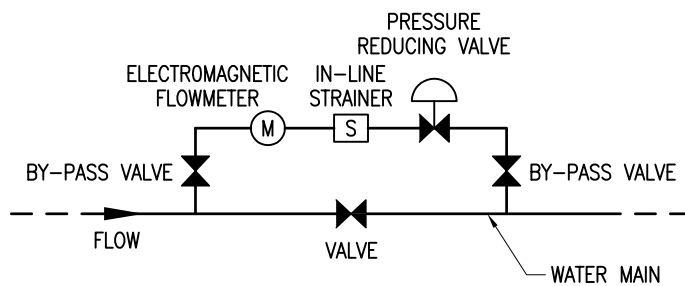

ARRANGEMENT OF FLOWMETER, IN-LINE STRAINER
AND PRESSURE REDUCING VALVE

ELECTROMAGNETIC FLOWMETER, PRESSURE REDUCING VALVE AND IN-LINE STRAINER COMBINED CHAMBER

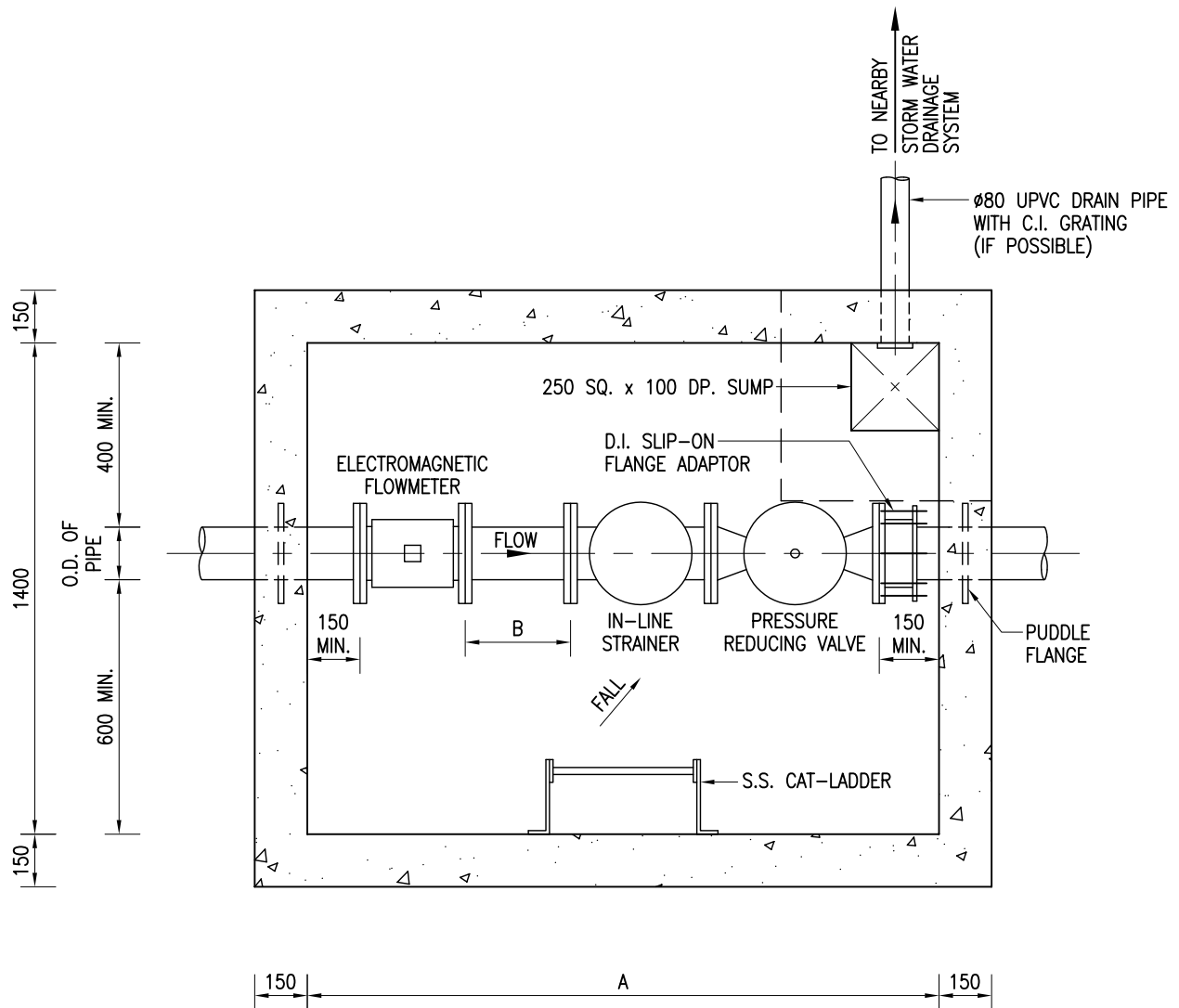

SECTIONAL PLAN

DIMENSIONS OF FLOWMETER, PRESSURE REDUCING VALVE AND IN-LINE STRAINER COMBINED CHAMBER

NOMINAL DIA. OF PIPE (DN)	80	100	150	200	250	300
A (mm)	1400	1550	1800	2200	2600	2900

ELECTROMAGNETIC FLOWMETER, PRESSURE REDUCING VALVE AND IN-LINE STRAINER COMBINED CHAMBER

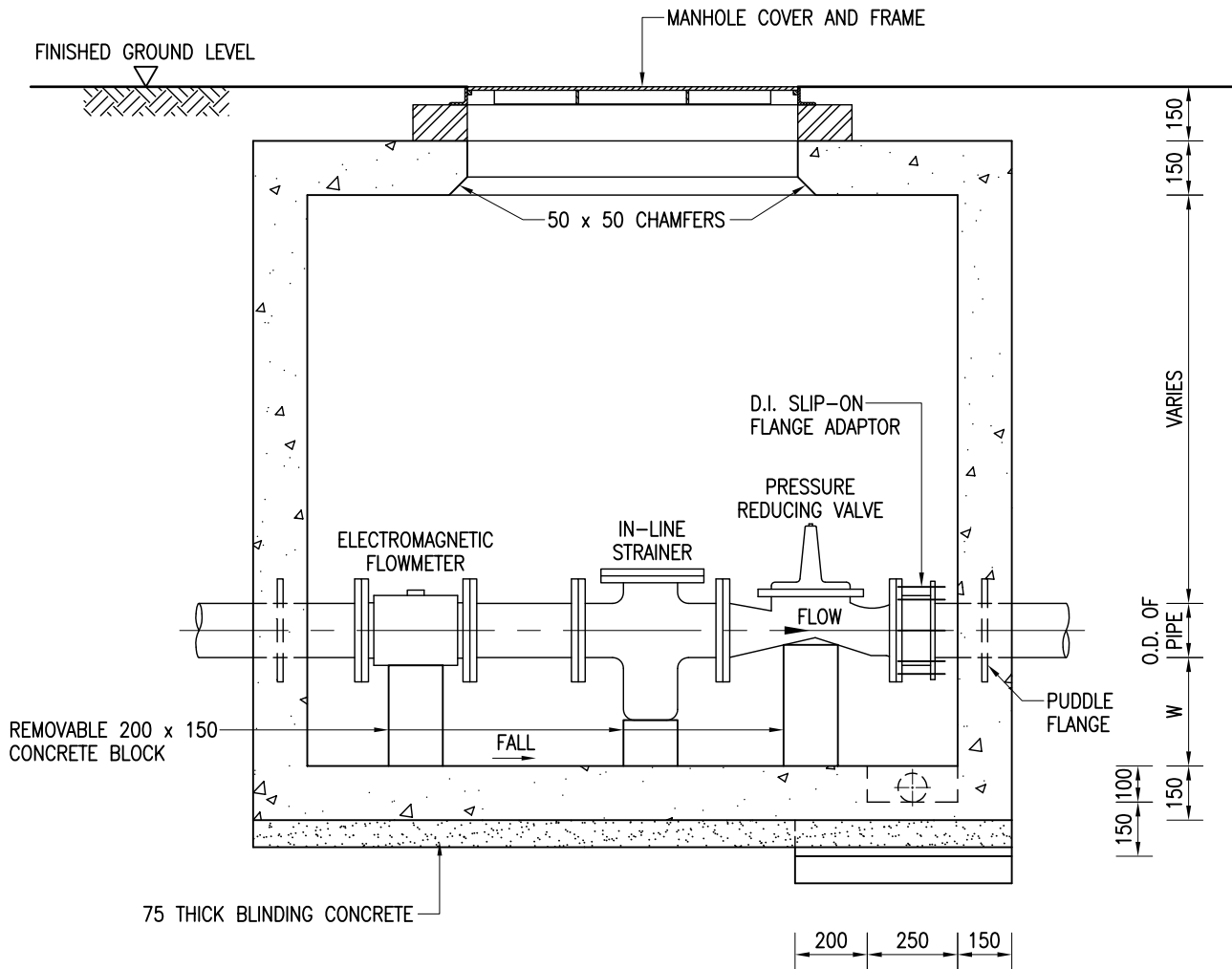

SECTION A - A

STANDARD MAINLAYING PRACTICE

APPENDIX 1.7
SHEET 4 of 5

ELECTROMAGNETIC FLOWMETER, PRESSURE REDUCING VALVE AND IN-LINE STRAINER COMBINED CHAMBER

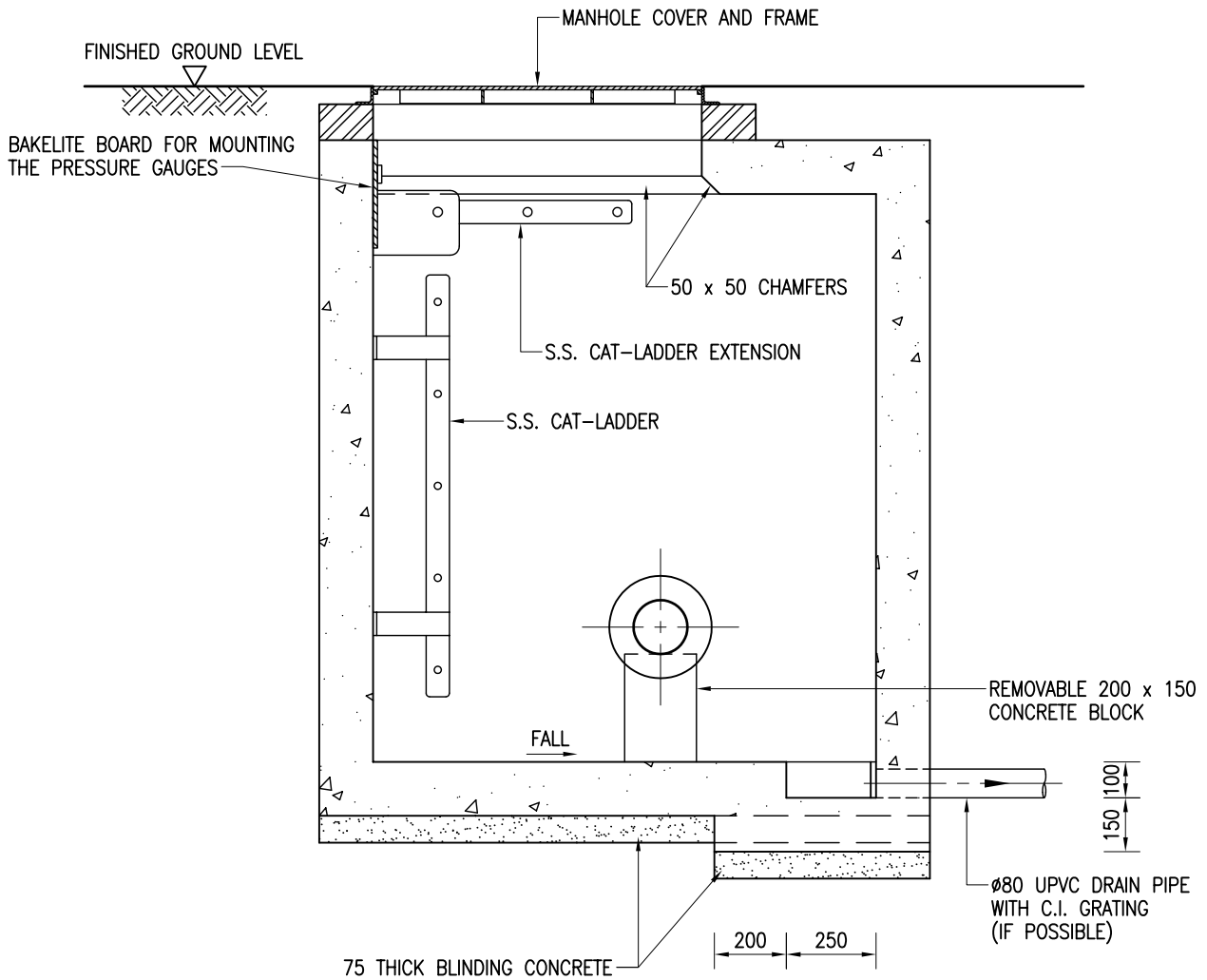

SECTION B - B

CAD REF. : AP010704.dwg



水務署
Water Supplies Department

ELECTROMAGNETIC FLOWMETER, PRESSURE REDUCING VALVE AND IN-LINE STRAINER COMBINED CHAMBER

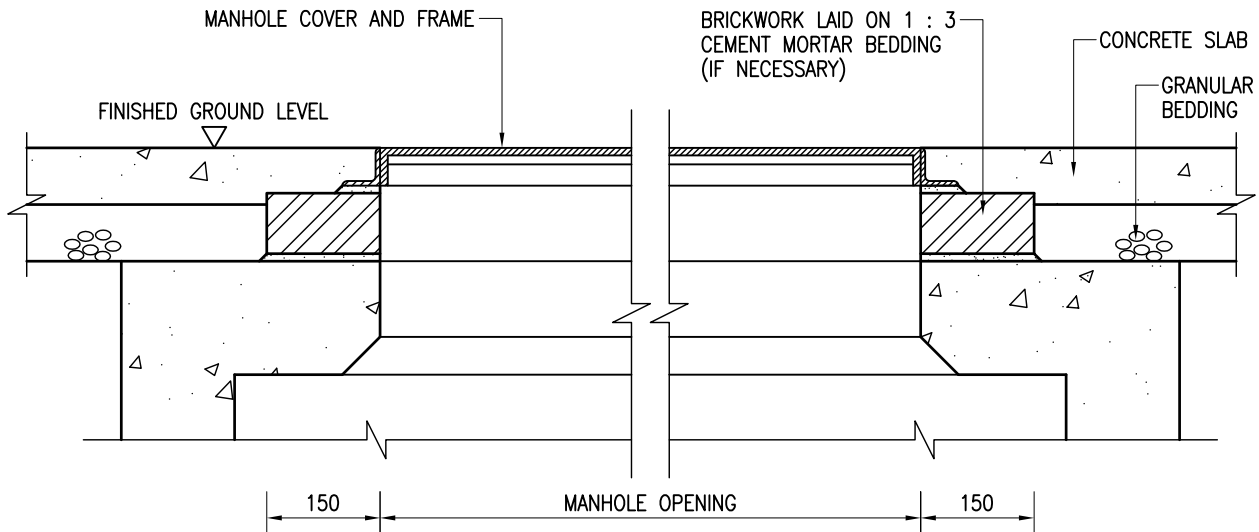

TOP TREATMENT APPLIED TO CONCRETE FOOTWAY

NOTES :

1. ALL DIMENSIONS ARE IN MILLIMETRES.
2. THE CHAMBER SHALL BE SITED ON FOOTWAY OR VERGE AREA TO AVOID TRAFFIC AND ON A BY-PASS PIPE BRANCHED OFF FROM THE MAIN PIPE.
3. THE CENTRE-LINE OF THE PIPE WITHIN THE CHAMBER SHALL BE HORIZONTAL UNLESS OTHERWISE APPROVED BY THE ENGINEER.
4. CONCRETE TO CHAMBER SHALL BE GRADE 35/20D. BLINDING CONCRETE SHALL BE GRADE 20/20D. MINIMUM CONCRETE COVER TO REINFORCEMENT SHALL BE 40mm.
5. REINFORCEMENT SHALL BE CUT TO SUIT OPENINGS AND THE SUMP PIT. BENDING AND SCHEDULING OF BARS SHALL COMPLY WITH BS 4466. MINIMUM LAP LENGTH FOR HIGH YIELD DEFORMED BARS SHALL BE $34 \times$ DIAMETER OF THE SMALLER LAPPED BAR UNLESS OTHERWISE SPECIFIED. FOR SIZE OF PIPE OPENING EQUAL TO OR EXCEEDING 200mm, PIPE OPENING REINFORCEMENT SHALL BE PROVIDED IN ACCORDANCE WITH DRAWING NO. WSD 1.12. FOR DESCRIPTION OF REINFORCEMENT, REFER TO DRAWING NO. WSD 7.1.
6. A MINIMUM OF 5D STRAIGHT PIPE UPSTREAM AND 2D STRAIGHT PIPE DOWNSTREAM FOR ELECTROMAGNETIC FLOWMETER FROM THE END OF ELECTROMAGNETIC FLOWMETER SHALL BE PROVIDED WHERE D IS THE NOMINAL DIAMETER OF THE PIPE. THE DIMENSIONS 5D AND 2D SHALL BE ADJUSTED IN ACCORDANCE WITH THE RECOMMENDATION OF THE SUPPLIER OF THE FLOWMETER AND AGREED BY THE ENGINEER.
7. THE FLOWMETER SHALL BE A BATTERY-POWERED ELECTROMAGNETIC FLOWMETER UNLESS OTHERWISE AGREED BY THE ENGINEER.
8. TAPERS SHALL BE PROVIDED ALONG THE PIPE OUTSIDE THE CHAMBER IN CASE THE PIPE AND BY-PASS VALVE HAVE DIFFERENT SIZES.
9. DRAIN PIPE FOR CHAMBER SHALL BE PROVIDED UNLESS FOUND TO BE IMPOSSIBLE ON SITE. DISCHARGE POINT OF THE DRAIN PIPE SHALL BE DETERMINED ON SITE BY THE ENGINEER.
10. FOR DETAILS OF STAINLESS STEEL CAT-LADDER AND EXTENSION, REFER TO DRAWING NO. WSD 7.3.
11. FOR DETAILS OF CAST IRON GRATING, REFER TO DRAWING NO. WSD 1.41.
12. FOR DETAILS OF MANHOLE COVER AND FRAME, REFER TO DRAWING NO. WSD 7.15 IN CASE OF CONCRETE FOOTWAY AND DRAWING NO. WSD 7.51 IN CASE OF FOOTWAY WITH PAVING BLOCKS.
13. FOR TOP TREATMENT APPLIED TO MANHOLE COVER OTHER THAN TO CONCRETE FOOTWAY, REFER TO DRAWING NO. WSD 1.24.
14. DIMENSION B SHALL NORMALLY BE $2 \times$ NOMINAL DIAMETER OF PIPE AND MAY BE REDUCED BY THE CONTRACTOR TO SUIT THE LENGTHS OF FLOWMETER, PRESSURE REDUCING VALVE AND IN-LINE STRAINER USED.
15. DIMENSION W SHALL NORMALLY BE 300mm. HOWEVER, IF Y-TYPE IN-LINE STRAINER IS TO BE INSTALLED, THE DIMENSION W SHALL BE ADJUSTED BY THE CONTRACTOR. SUCH ADJUSTMENT SHALL BE APPROVED BY THE ENGINEER.
16. DIMENSIONS OF THE CHAMBER SHALL BE ADJUSTED BY THE CONTRACTOR TO SUIT SITE CONDITIONS. SUCH ADJUSTMENT IN DIMENSIONS OF THE CHAMBER SHALL BE APPROVED BY THE ENGINEER.
17. EXACT POSITIONS FOR MOUNTING THE DATA LOGGER AND BAKELITE BOARD ONTO THE WALL OF THE CHAMBER SHALL BE DETERMINED ON SITE BY THE ENGINEER.

CRITICAL PRESSURE POINT PIT ON FOOTPATH

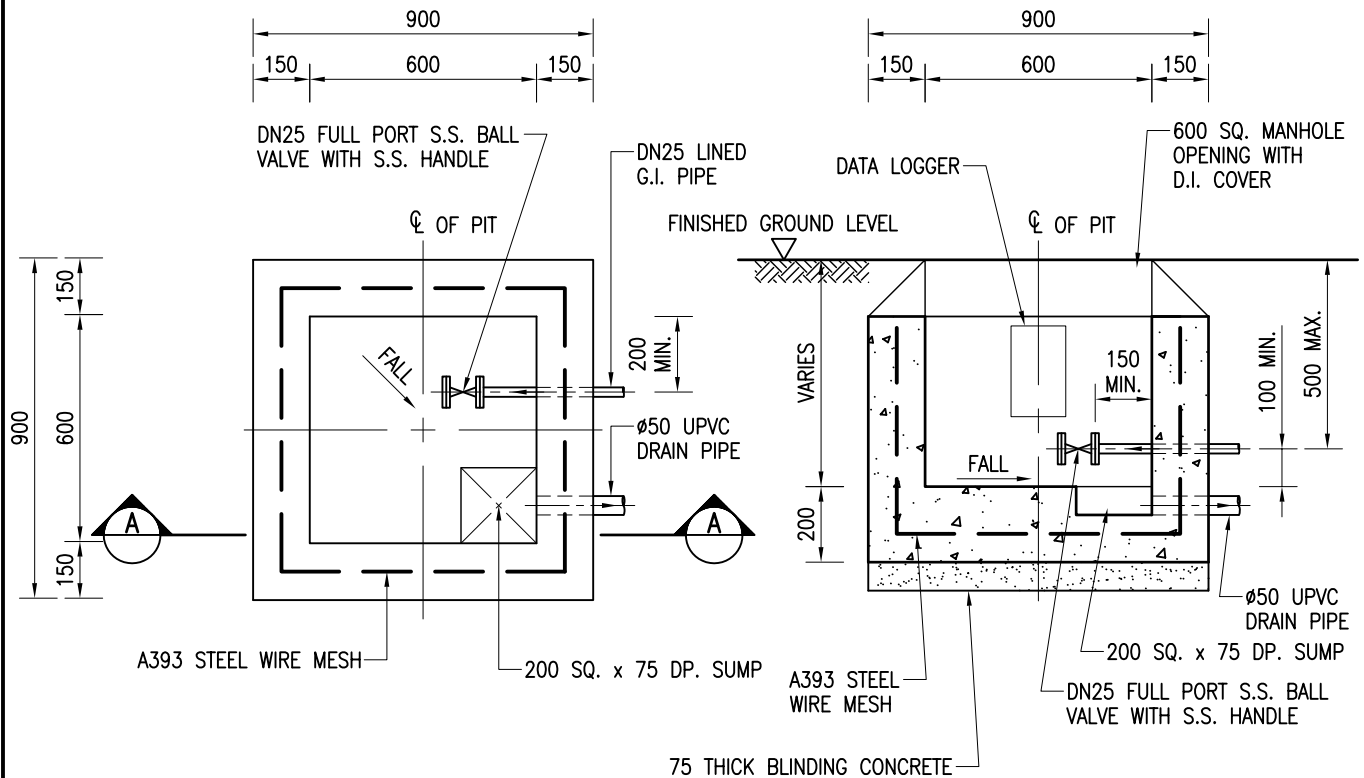

PLAN

SECTION A - A

STANDARD DETAILS

(COVER NOT SHOWN FOR CLARITY)

NOTES :

1. ALL DIMENSIONS ARE IN MILLIMETRES.
2. THE PIT SHALL BE SITED ON FOOTWAY OR PAVEMENT WITHOUT VEHICULAR TRAFFIC IN NORMAL CONDITION.
3. CONCRETE TO CHAMBER SHALL BE GRADE 35/20D. BLINDING CONCRETE SHALL BE GRADE 20/20D. MINIMUM CONCRETE COVER TO REINFORCEMENT SHALL BE 40mm.
4. STANDARD DETAILS SHALL BE FOLLOWED UNLESS OTHERWISE AGREED BY THE ENGINEER TO USE ALTERNATIVE DETAILS UNDER SPECIFIC CONDITIONS SUCH AS INADEQUATE SPACE ON SITE.
5. DRAIN PIPE FOR PIT SHALL BE PROVIDED UNLESS FOUND TO BE IMPOSSIBLE ON SITE. DISCHARGE POINT OF THE DRAIN PIPE SHALL BE DETERMINED ON SITE BY THE ENGINEER.
6. FOR DETAILS OF SURFACE BOX, REFER TO DRAWING NO. WSD 7.47.
7. FOR DETAILS OF MANHOLE COVER, REFER TO DRAWING NO. WSD 7.48.
8. FOR DETAILS OF TYPE I AND TYPE II PRECAST CONCRETE UNITS AND MILD STEEL TIE, REFER TO DRAWING NO. WSD 1.7.
9. FOR TOP TREATMENT APPLIED TO MANHOLE COVER, REFER TO DRAWING NO. WSD 1.24.
10. EXACT POSITION FOR MOUNTING THE DATA LOGGER ONTO THE WALL OF THE PIT SHALL BE DETERMINED ON SITE BY THE ENGINEER.

CRITICAL PRESSURE POINT PIT ON FOOTPATH

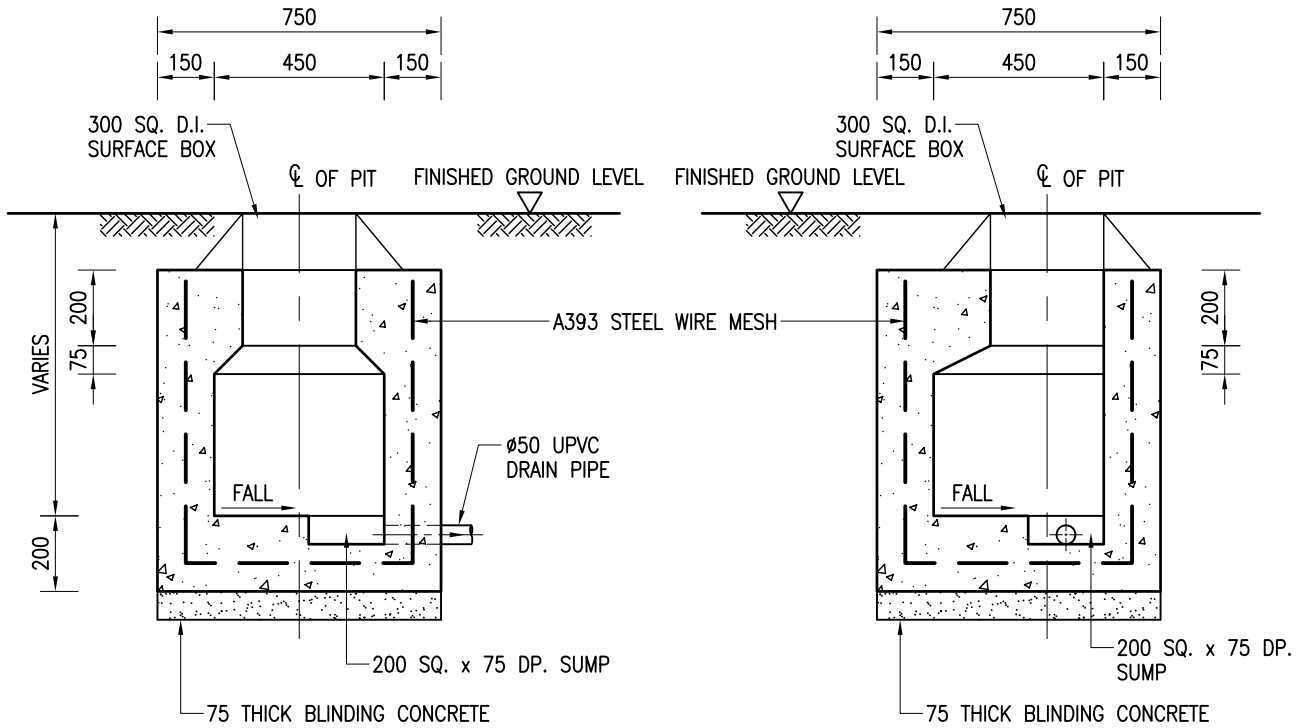

SECTION B - B

SECTION C - C

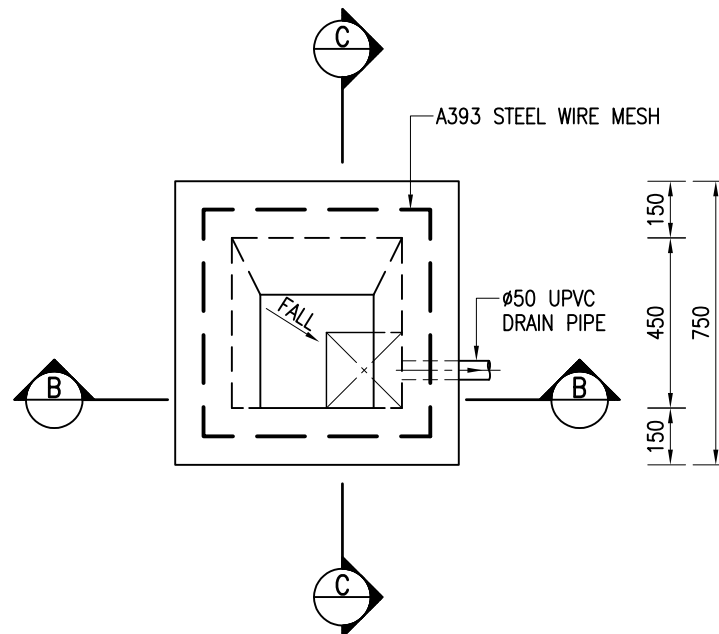

PLAN

ALTERNATIVE DETAILS -
USING 300 SQ. DUCTILE IRON SURFACE BOX
(COVER, DATA LOGGER AND DN25 PIPE NOT SHOWN FOR CLARITY)

CRITICAL PRESSURE POINT PIT ON FOOTPATH

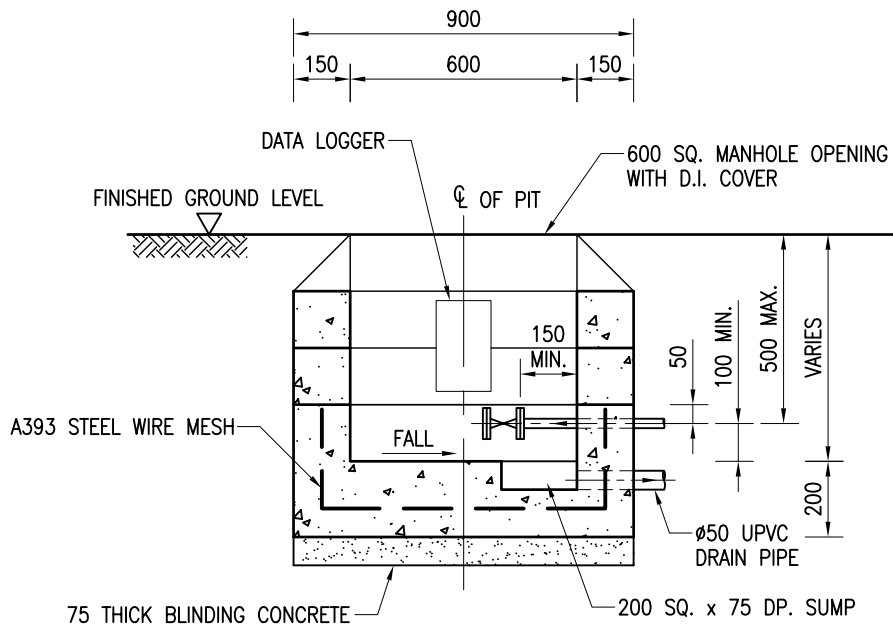

SECTION D - D

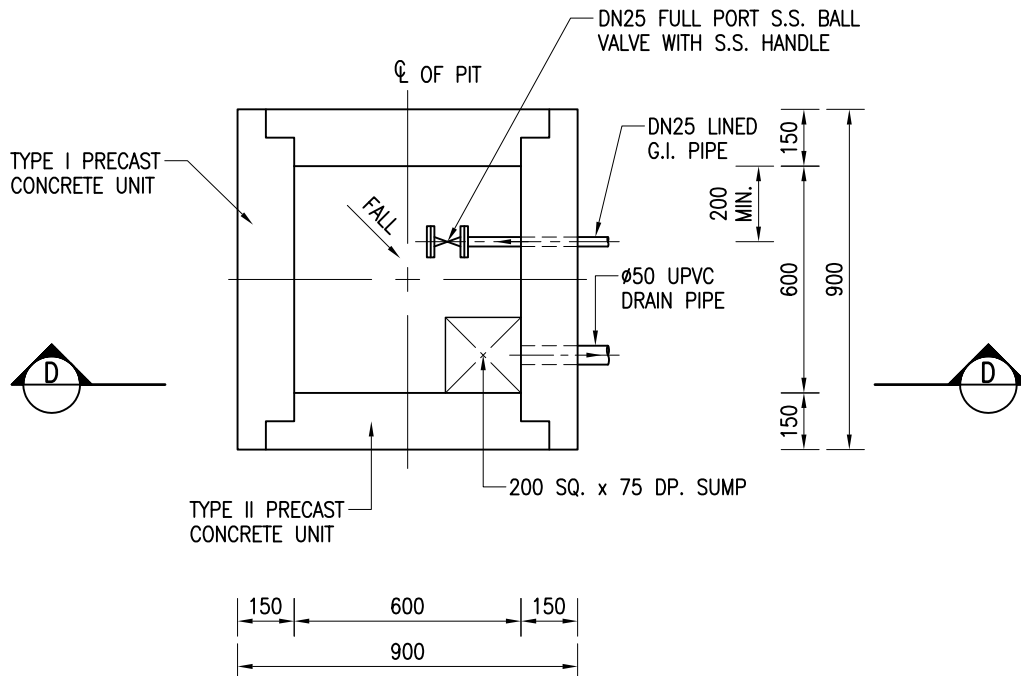

PLAN

ALTERNATIVE DETAILS - USING PRECAST CONCRETE UNIT FOR CONSTRUCTION OF PIT WALL

(COVER NOT SHOWN FOR CLARITY)

CRITICAL PRESSURE POINT PIT ON FOOTPATH

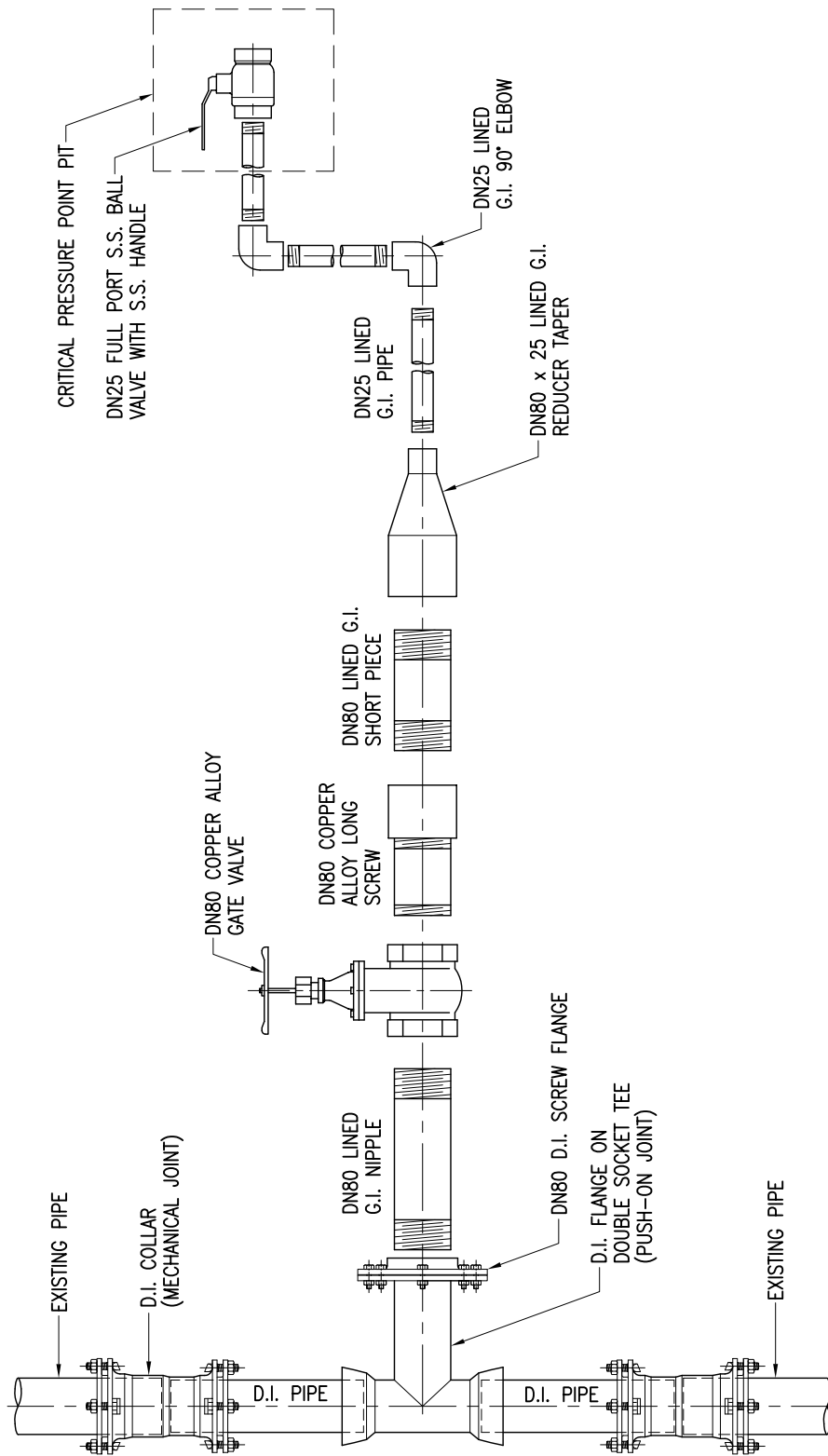

TYPICAL DETAILS OF CONNECTION
ARRANGEMENT FOR DUCTILE IRON PIPE TO
CRITICAL PRESSURE POINT PIT

CONTACT POINT FOR LEAK NOISE CORRELATION

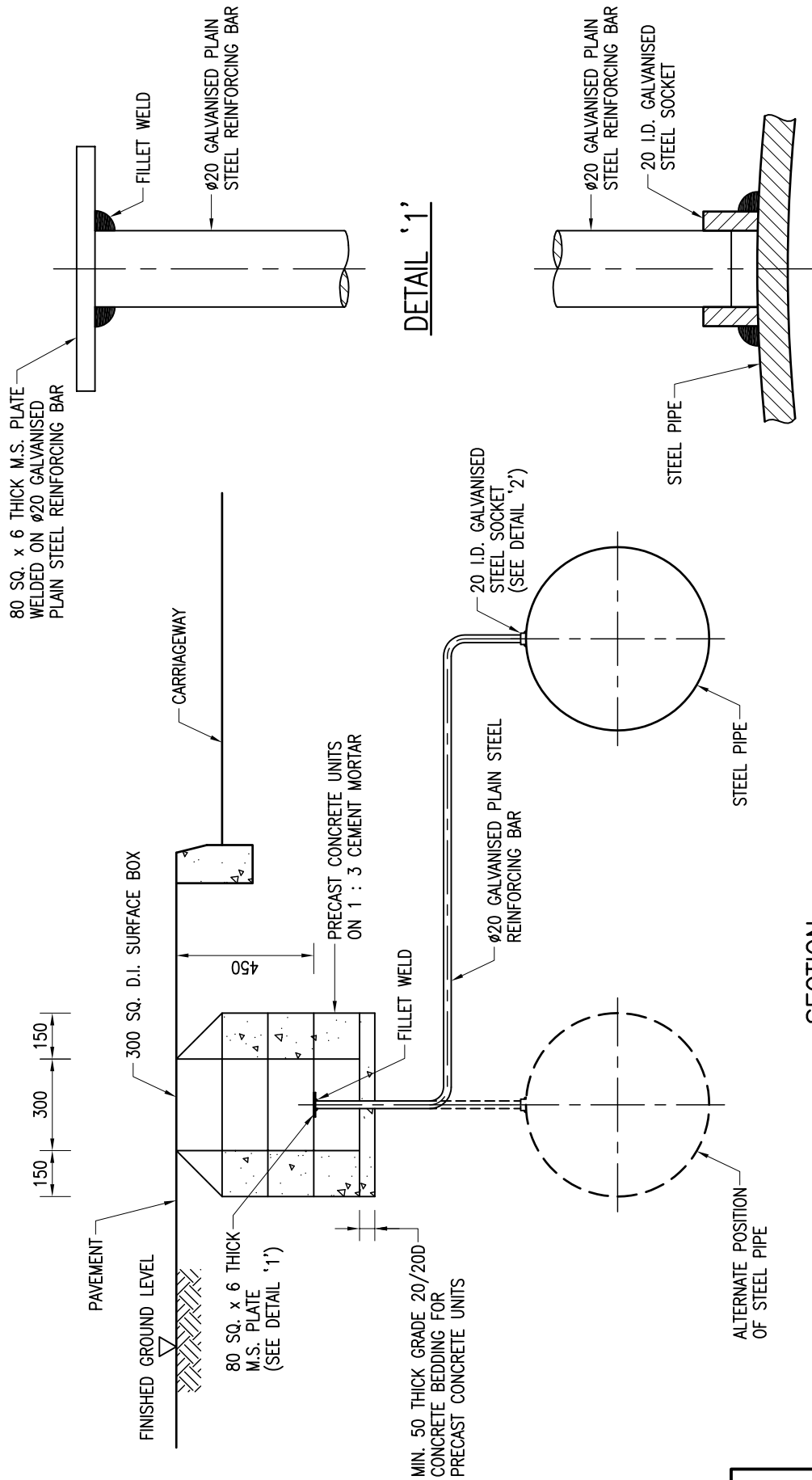

NOTE :

- CONTACT POINTS FOR TRUNK MAIN SHALL BE INSTALLED WHERE NO OTHER FITTINGS (e.g. VALVE, AIR VALVE, HYDRANT etc.) ARE ACCESSIBLE WITHIN 200 METRES DISTANCE.
- ALL WELDS SHALL BE 3mm FILLET WELD.



SPECIAL JOINTS FOR STEEL PIPES

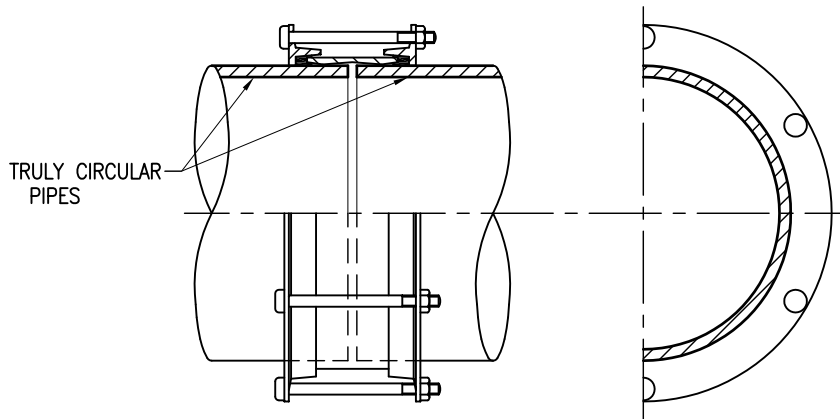

SPECIAL JOINT FOR STEEL PIPE – PIPE COUPLING

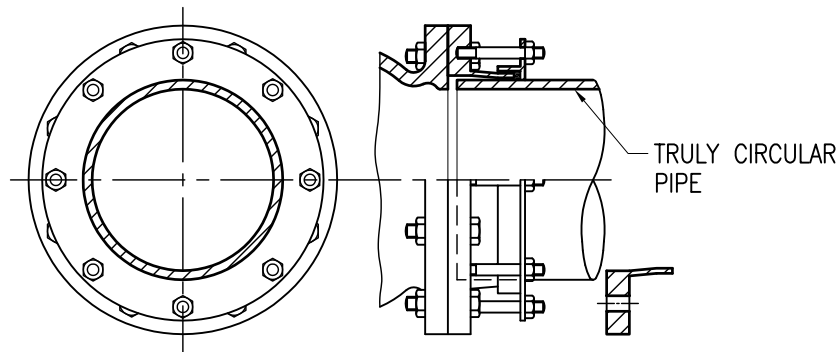

SPECIAL JOINT FOR STEEL PIPE –
FLANGE ADAPTOR FOR CONNECTION TO VALVE

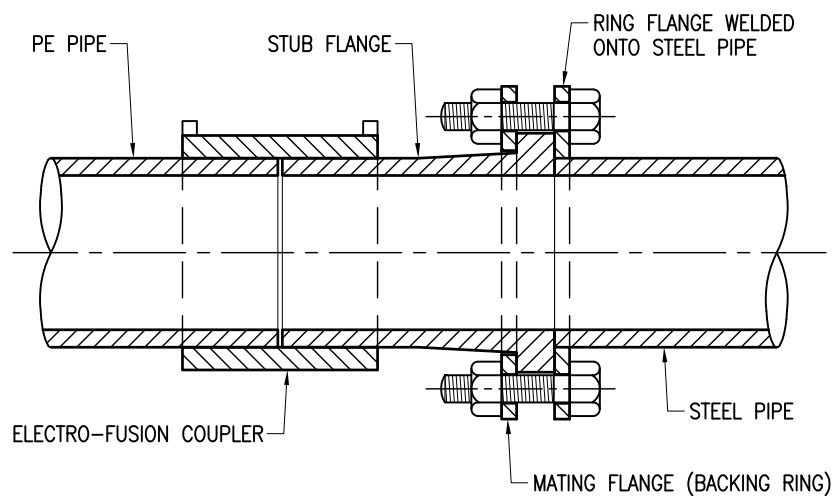

SPECIAL JOINT FOR STEEL PIPE –
CONNECTION OF STEEL PIPE TO POLYETHYLENE PIPE

CAD REF. : AP020100.dwg



CONNECTION OF TWO STEEL PIPES USING DUCTILE IRON PIPE

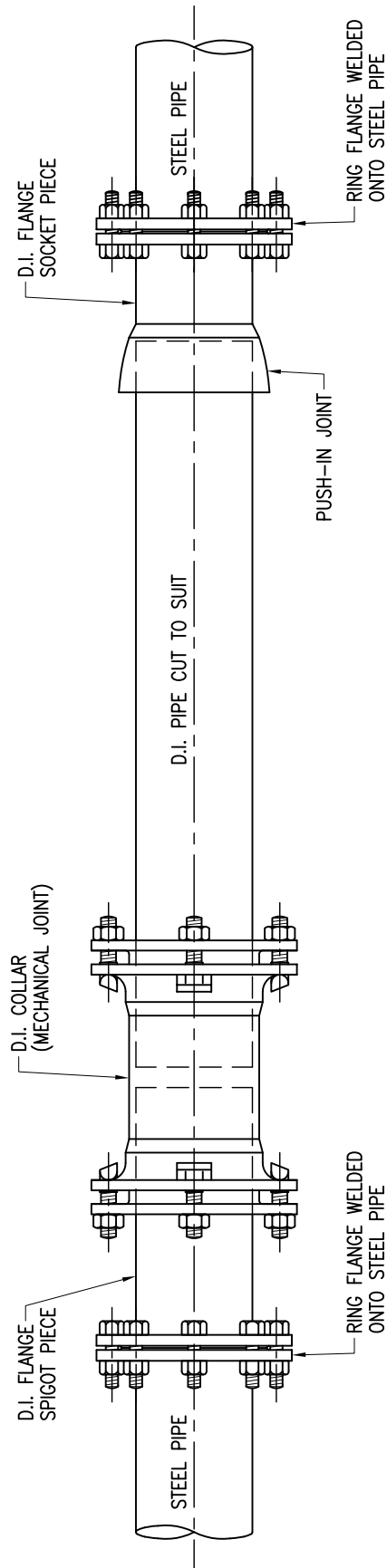

NOTE :

1. ALL FLANGES OF DUCTILE IRON FITTINGS ARE FLANGE TYPE PN16.
2. A DUCTILE IRON FLANGE ADAPTOR MAY BE USED INSTEAD OF A DUCTILE IRON COLLAR AND A DUCTILE IRON FLANGE SPIGOT PIECE.

CONNECTIONS FOR DUCTILE IRON PIPES

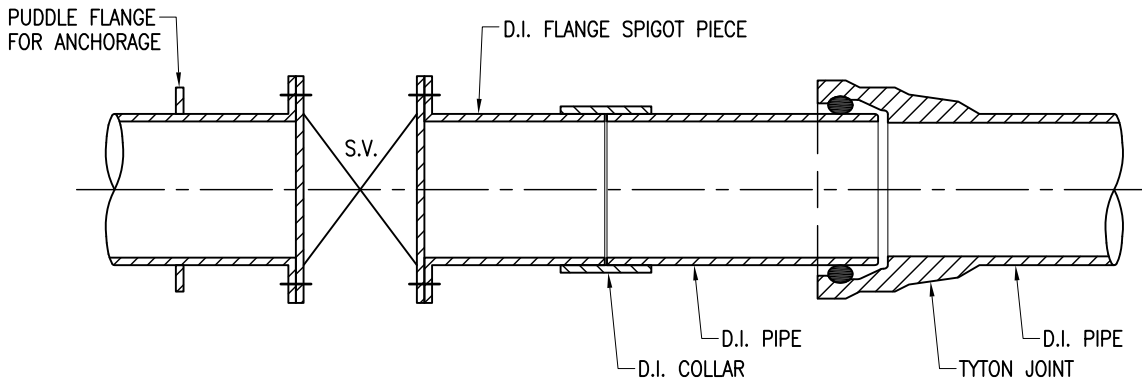

CONNECTION OF DUCTILE IRON PIPE TO VALVE

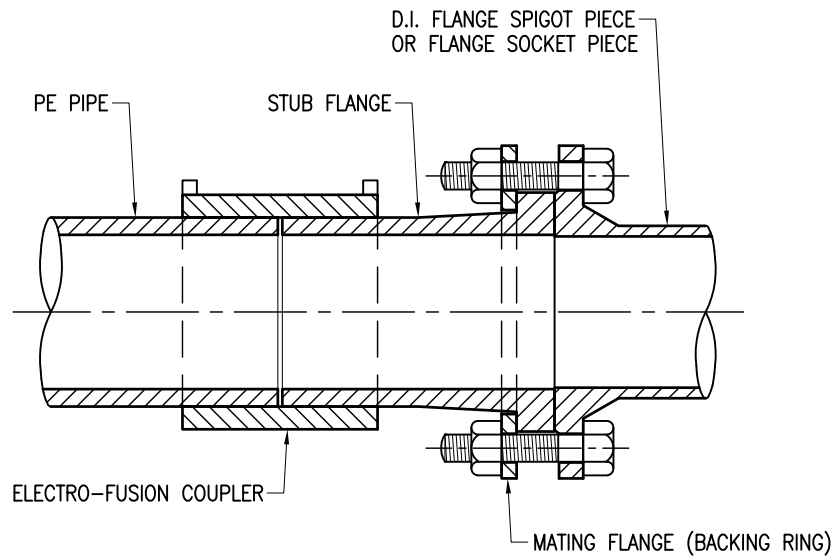

CONNECTION OF DUCTILE IRON PIPE TO POLYETHYLENE PIPE

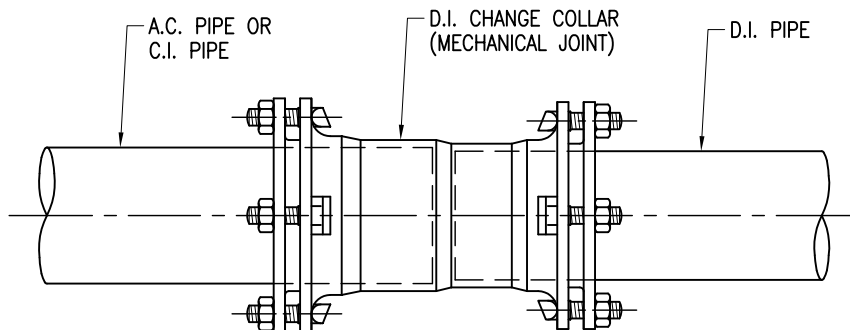

CONNECTION OF DUCTILE IRON PIPE TO ASBESTOS CEMENT OR CAST IRON PIPE

ALL FLANGES OF DUCTILE IRON FITTINGS ARE FLANGE TYPE PN16

CONNECTION OF GALVANISED IRON PIPE TO VALVE

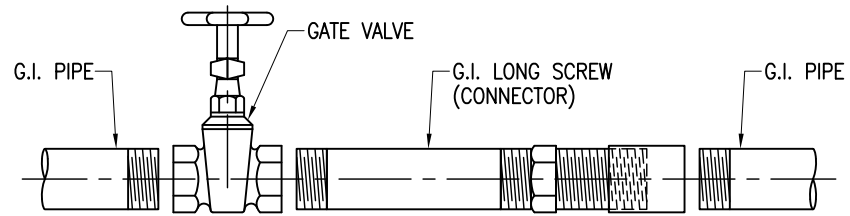

TEE CONNECTION FROM ASBESTOS CEMENT OR CAST IRON PIPES

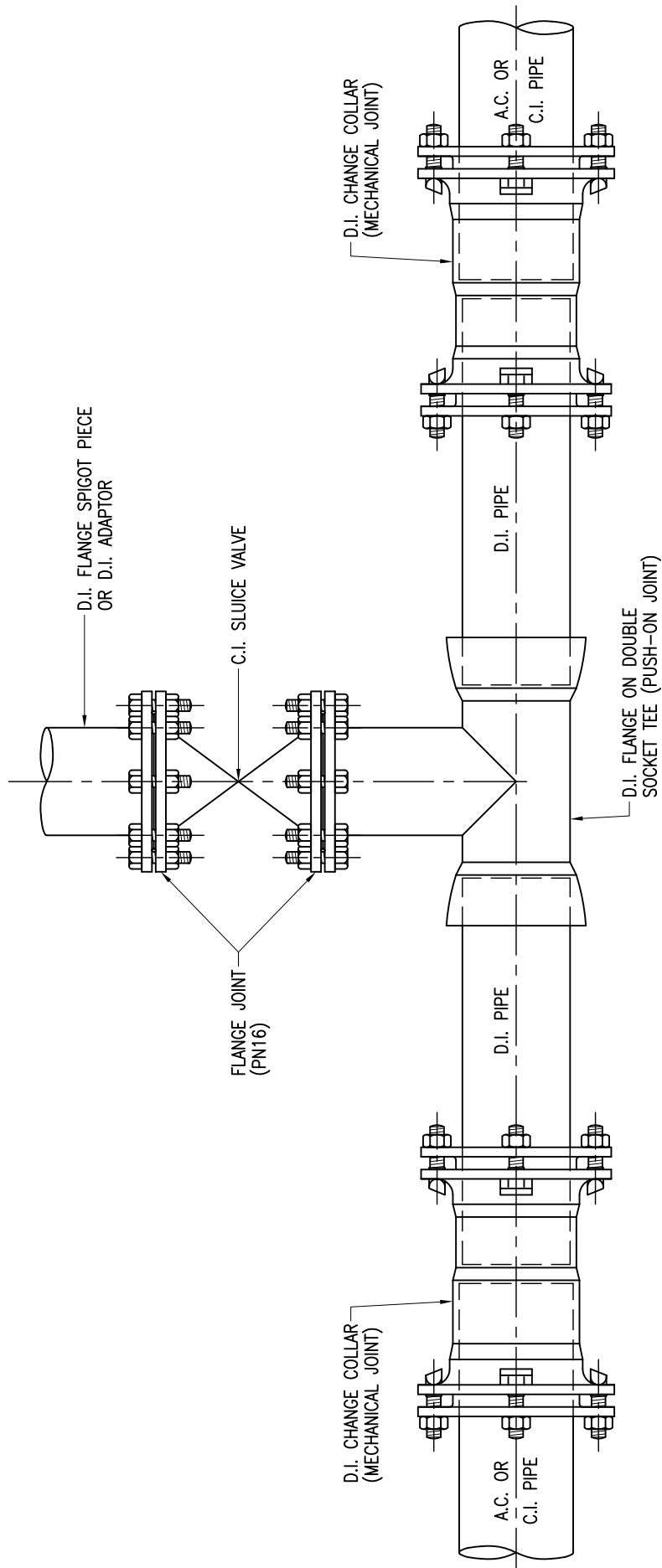

NOTE :

1. ALL FLANGES OF DUCTILE IRON FITTINGS ARE FLANGE TYPE PN16.

REPAIRS TO WATER MAINS

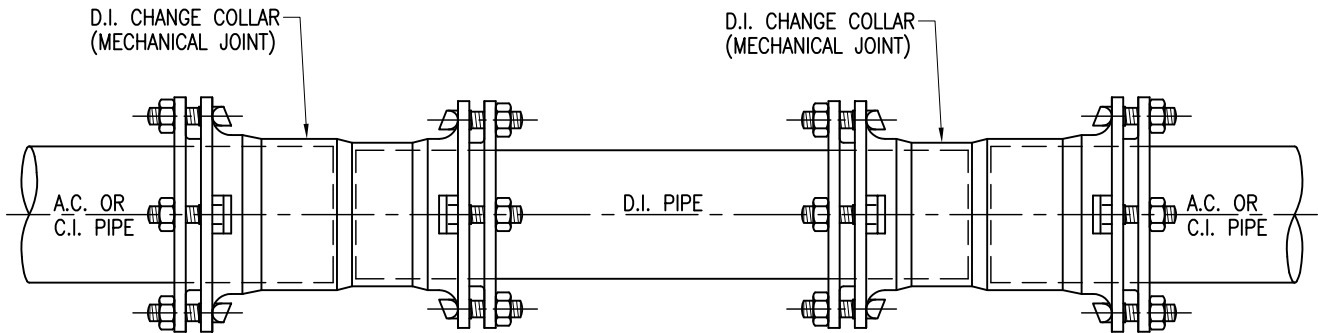

REPAIR TO CAST IRON OR ASBESTOS CEMENT PIPE

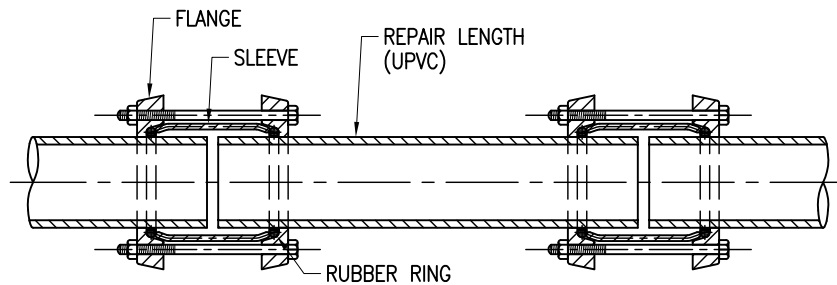

DRESSER JOINT

REPAIR TO $\phi 100\text{mm}$ OR $\phi 80\text{mm}$ UNPLASTICISED POLYVINYL CHLORIDE PIPE

DRESSER JOINT OR CAST IRON REPAIR COUPLING IS USED FOR $\phi 80\text{mm}$ OR $\phi 100\text{mm}$ UNPLASTICISED POLYVINYL CHLORIDE PIPE

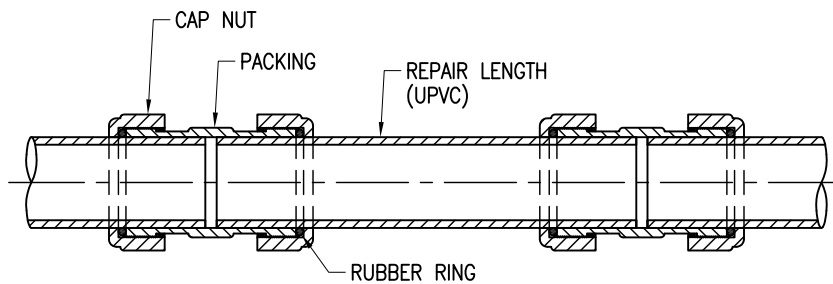

SIMPLE JOINT

REPAIR TO $\phi 50\text{mm}$ OR SMALLER UNPLASTICISED POLYVINYL CHLORIDE PIPE

SIMPLE JOINT OR UNPLASTICISED POLYVINYL CHLORIDE REPAIR COUPLING IS USED FOR UNPLASTICISED POLYVINYL CHLORIDE PIPE

JOINTS ON EXISTING CAST IRON WATER MAINS

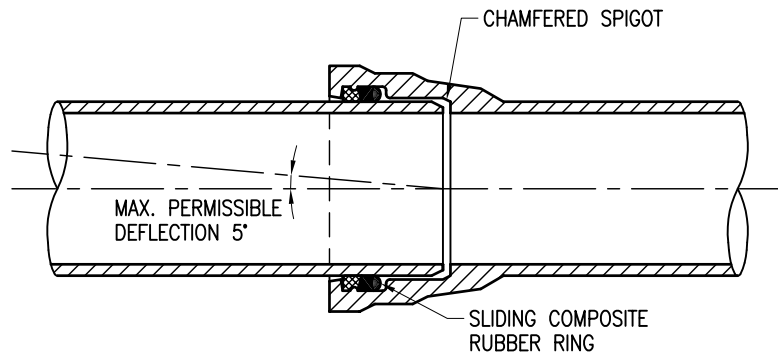

TYTON JOINT

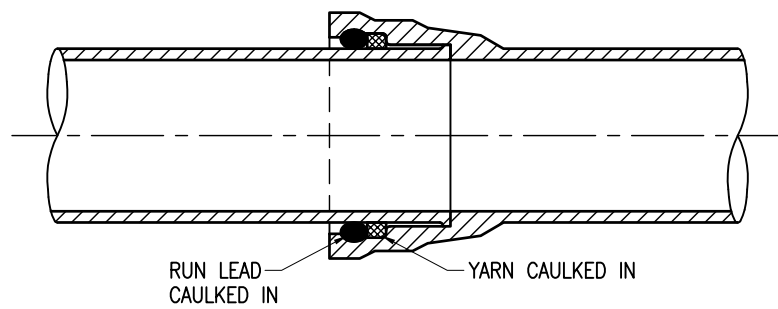

SPIGOT AND SOCKET (RUN LEAD)

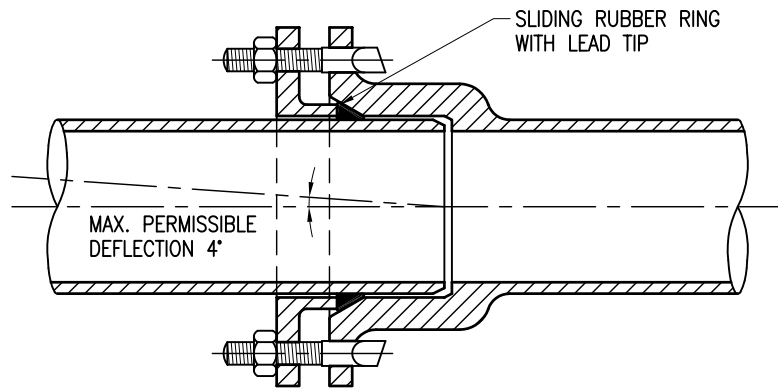

BOLTED JOINT

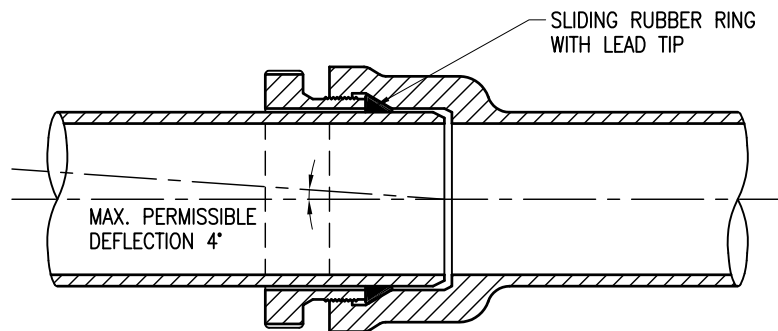

SCREWED GLAND

RESTRICTED ZONE FOR UTILITIES AROUND DEEP SUMP GULLIES

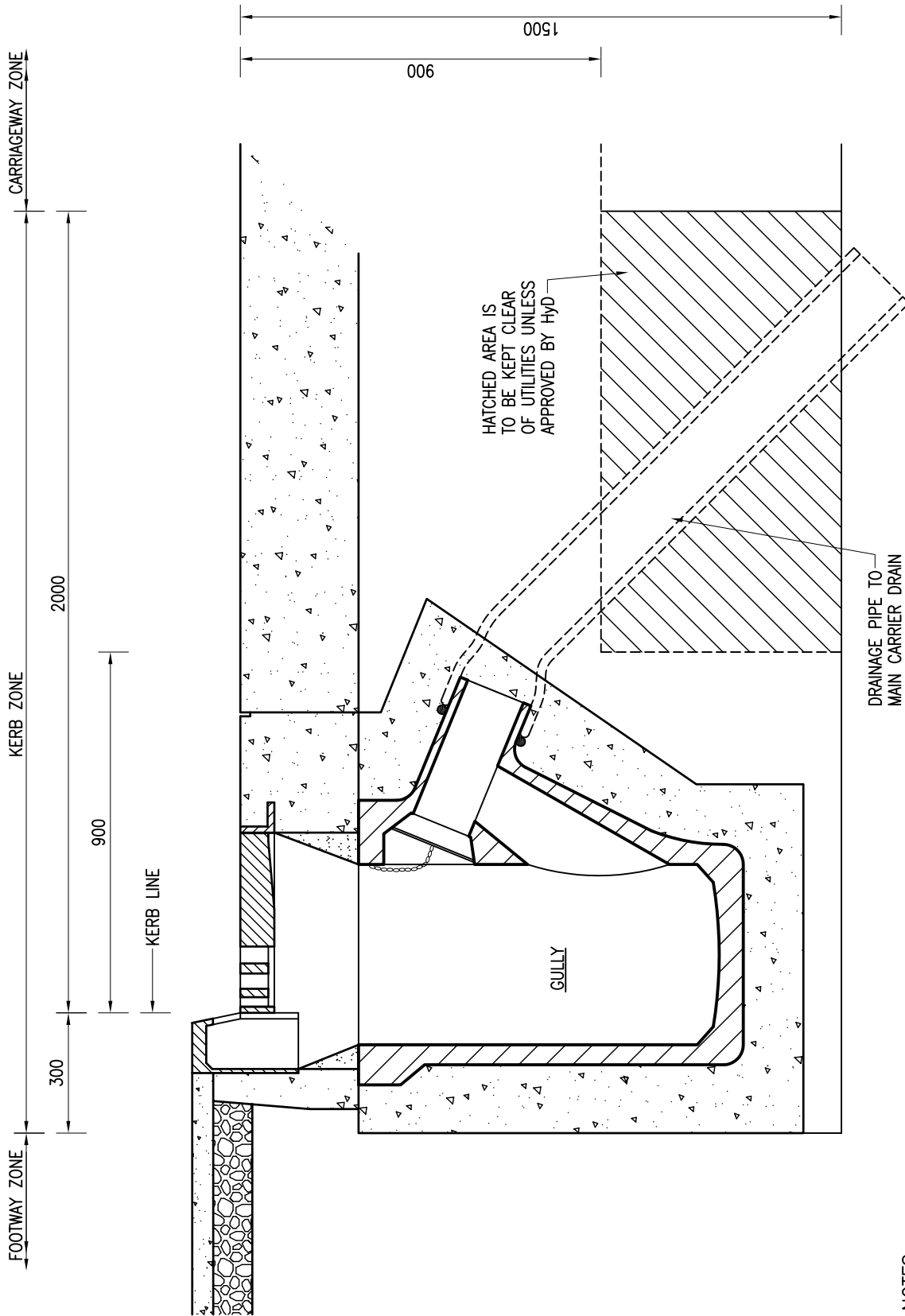

NOTES :

1. ALL DIMENSIONS ARE IN MILLIMETRES.
2. DETAILS OF GULLY ARE BASED ON HYD STANDARD DRAWING H3110A.

MEMO

<i>From</i> <u>E/C</u>	<i>To</i> <u>E/Region (Distribution)</u>
<i>Ref.</i> _____ <i>in</i> _____	<i>(Attn.:</i> _____ <i>)</i>
<i>Tel. No.</i> _____	<i>Your Ref.</i> _____ <i>In</i> _____
<i>Fax. No.</i> _____	<i>dated</i> _____ <i>Fax. No.</i> _____
<i>Date</i> _____	<i>Total pages</i> _____

**HYDROSTATIC PRESSURE TEST RESULT ON _____ DIA. _____ MAIN _____ LENGTH
LOCATION - _____**

Please be informed that a hydrostatic pressure test has been performed on the above mentioned pipeline. Details as certified by the undersigned Waterworks Inspector are as follows:-

- (a) Level of Pressure Gauge (APD) _____ metre
- (b) T.W.L. of Service Reservoir (APD) _____ metre
- (c) Lowest Level of Mains (APD) _____ metre
- (d) Maximum Working Head (= (b) minus (c)) _____ metre
- (e) Required Test Head (_____ times (d)) _____ metre
- (f) Height of Pressure Gauge above the Lowest Point _____ metre
- (g) Required Test Pressure Reading (= (e) minus (f)) _____ metre = _____ kPa
- (h) Pressure Reading of _____ kPa maintained for _____ hours (1 m = 1.42 p.s.i.)
- (i) Leakage _____ litres = _____ litres per hour
- (j) Permissible Leakage = _____ litres per hour
- (k) Remarks and Plan Reference (if any) : _____

2 This section of pipeline has been cleaned and sterilised in accordance with DI No. 805.

3 Certified by :

Works Supervisor/

Waterworks Inspector/

Engineer/Construction

Guidelines in Making Replacement Service Connections in R&R Works

Goals:

1. To avoid illegal connections and thus minimise loss of water
2. To improve operation efficiency and customer services

Objectives:

1. To avoid reinstating illegal connections and abandoned tees when making replacement service connections
2. To keep records of those suspicious connections for future follow up action if situation does not permit verification of the legality of the existing connections
3. To make provisions to allow for future investigation of water loss (due to e.g. leakage or illegal connections) in the inside services downstream from the replacement service connections
4. To map the correlation between the premises where the registered consumers reside and the corresponding service tee connections

Guidelines

Item Ref.	Item Description	Action Party	Enabling Party
	(A) Site Works		
A01	Study the scope of connection works and seek advice from Region on the corresponding probable boundary of supply at an appropriate stage for planning of connection works. (See also Note 1)	Designer/ RSS	Region
	[Note 1: AM Section has arranged DO/HQ to disseminate a shape file containing georeferenced grids of premises with registered consumers for RSS' viewing and reference. Action completed]	DO/HQ	AM
A02	Identify as far as practicable legitimate consumers and their corresponding connection points (CP) along the new water mains based on MRP/site inspections/liaison with	RSS	

Item Ref.	Item Description	Action Party	Enabling Party
	consumers at an appropriate stage and map these CPs with the consumer meters/premises, and record those unmapped/uncharted connections for further investigation by others. (See Note 2)		
	[Note 2: a legitimate connection point is a connection which connects WSD water mains to a private mains (or inside/fire service) to serve at least one legitimate consumer (i.e. to a registered consumer meter or fire service). There may be cases where illegal connections are made along the existing mains/inside services but before the consumer meters. These cases are to be dealt with separately in A07 and the “C” series of these Guidelines.]		
A03	Conduct valve operation, if desirable and practicable, in planning the connection of the existing CPs to the new mains. Record the findings to facilitate future mapping.	RSS	
A04	Seek Region’s assistance for difficult cases (e.g. those involving suspicious types of pipe materials, abnormal connection arrangement (including e.g. tee without isolation valve), long buried inside services before meters etc).	RSS	Region
A05	Solicit assistance from Customer Service Division (CSD) for remaining difficult cases (e.g. RSS could not gain access for site inspection).	Region	CSD
A06	Make connections only for legitimate CP subject to the provisions in B05. When making such connections, considerations should be made to shorten as far as possible the length of supply pipe and the inside service, i.e. the connection point should be as close to the premises as possible, all subject to the site/project constraints, in consultation with Region when necessary.	RSS	Region
A07	Advise Designer/RSS to install check meters or make provision for future installation of check meters at the connection points for those suspicious inside services (e.g. those of long length and mostly buried with reasonable ground for suspicion). In cases where installation of check meters could not be accommodated in R&R works, Region to take it up.	CSD	Designer /RSS/Region

Item Ref.	Item Description	Action Party	Enabling Party
A08	Prepare a report as shown in Annex 1 to Region with a copy to AM Section (for posting to the DMS, if feasible).	RSS	
A09	Submit as-built record via RRDMS (or in hard copies where RRDMS submissions are inapplicable) for the identified legitimate connection points and correlate them with the premises identified to be served by the new mains. In cases where the mapped premises do not exist on the base map, correlation could be indicated on hard copies with an outline of the concerned premises together with available details (such as address) for future follow up. Such information should be included in the report on replacement service connections (see A08).	RSS	
A10	Report irregularities (e.g. illegal connections teed off from inside services or leakage of inside services) found on site to CSD.	RSS	CSD
	(B) Checking of uncharted tees		
B01	When connecting the new water mains to the system, install additional valves on the existing water mains to be abandoned for checking uncharted service water main connections.	RSS	
B02	After completion of CP connections, close the additional valves installed on the existing water mains for checking any uncharted CP.	RSS	
B03	Upon receipt of no water supply from premises due to B02, conduct site inspection to confirm the existence of any uncharted CP. Supply from the existing water mains may be temporarily reinstated during the course of investigation.	RSS	Region
B04	If the uncharted CP has consumer meters, make connections to the new water main. When making such connections, considerations should be made to shorten as far as possible the length of supply pipe and the inside service, i.e. the connection point should be as close to the premises as possible, all subject to the site/project constraints, in consultation with Region when necessary.	RSS	Region

Item Ref.	Item Description	Action Party	Enabling Party
B05	For uncharted CP confirmed to have no consumer meter, no replacement connection should be made and RSS should inform CSD to follow up with the consumer. For uncharted CP where legitimate consumer meter could not be ascertained (e.g. due to consumer's uncooperative attitude, RSS should advise CSD to follow up immediately. CSD should advise RSS whether connection should be made as soon as practicable on the understanding that the R&R programme should not be adversely impacted. Should replacement connection be made eventually without confirming the legitimacy of the connection because of other over-riding considerations, RSS should take and include all necessary records into the Report set out in A08 for future follow up action.	RSS	CSD
	(C) Measures to minimise inside service leakage and facilitate future investigation of water loss		
C01	Advise Designer/RSS to install flowmeter on the existing network to enable monitoring of the network performance including inside services before and after R&R works. In cases where installation of flowmeters could not be accommodated in R&R works, Region to take it up.	WLM	Designer /RSS/ Region
C02	Rationalise the supply network for simplification and improvement of supply redundancy; consider if the bundle of inside services could be replaced by a common water main (i.e. to shorten the length of inside services and thus possibility of inside service leakage and illegal connections) subject to site/project constraints including land, villagers' reaction, etc.	Designer /RSS	Region

From : [Project Division]

To : [Region]

**Report on Replacement Service Connections
Made under Works Order No.??? under Contract No.???**

(A) Background Information

Name of Consultant:

Name of Contractor:

Contract No.:

Contract Title:

Works Order No.:

Date of commencement of Works Order:

Date of completion of Works Order:

(B) Mapped premises not included in RRDMS due to non-existence of the premises on the basemap

*NIL/Please refer to Drawing No. ??? in Annex 1 (note: with legend to show these connections)

Connection Reference (say MC 01):

VRN of the tee valves:

Record Site Photos

Connection Reference (say MC 02):

VRN of the tee valves:

Record Site Photos

...

...

...

...

...

...

(C) Unmapped premises with legitimate consumers

*NIL/Please refer to Drawing No.: ??? in Annex 1 (note: with legend to show unmapped premises)

Premises Reference (say PR 01):

Meter(s) no:

Record Site Photos

Premises Reference (say PR 01):

Meter(s) no:

Record Site Photos

...

...

...

...

...

...

(D) Suspected illegal/abandoned mains not connected

*NIL/Please refer to Drawing No. ??? in Annex 1 (note: with legend to show these connections)

Connection Reference (say IC 01):

Record Site Photos

Connection Reference (say IC 02):

Record Site Photos

...

...

...

...

...

...

**(E) Suspicious connections reinstated and required follow up investigation by
Region/CS Division**

*NIL/Please refer to Drawing No. ??? in Annex 1 (note: with legend to show these connections)

Connection Reference (say SC 01):

VRN of the tee valve:

Record Site Photos

Connection Reference (say SC 02):

VRN of the tee valve:

Record Site Photos

...

...

...

...

...

...

* Delete where inapplicable

CATHODIC PROTECTION SYSTEM

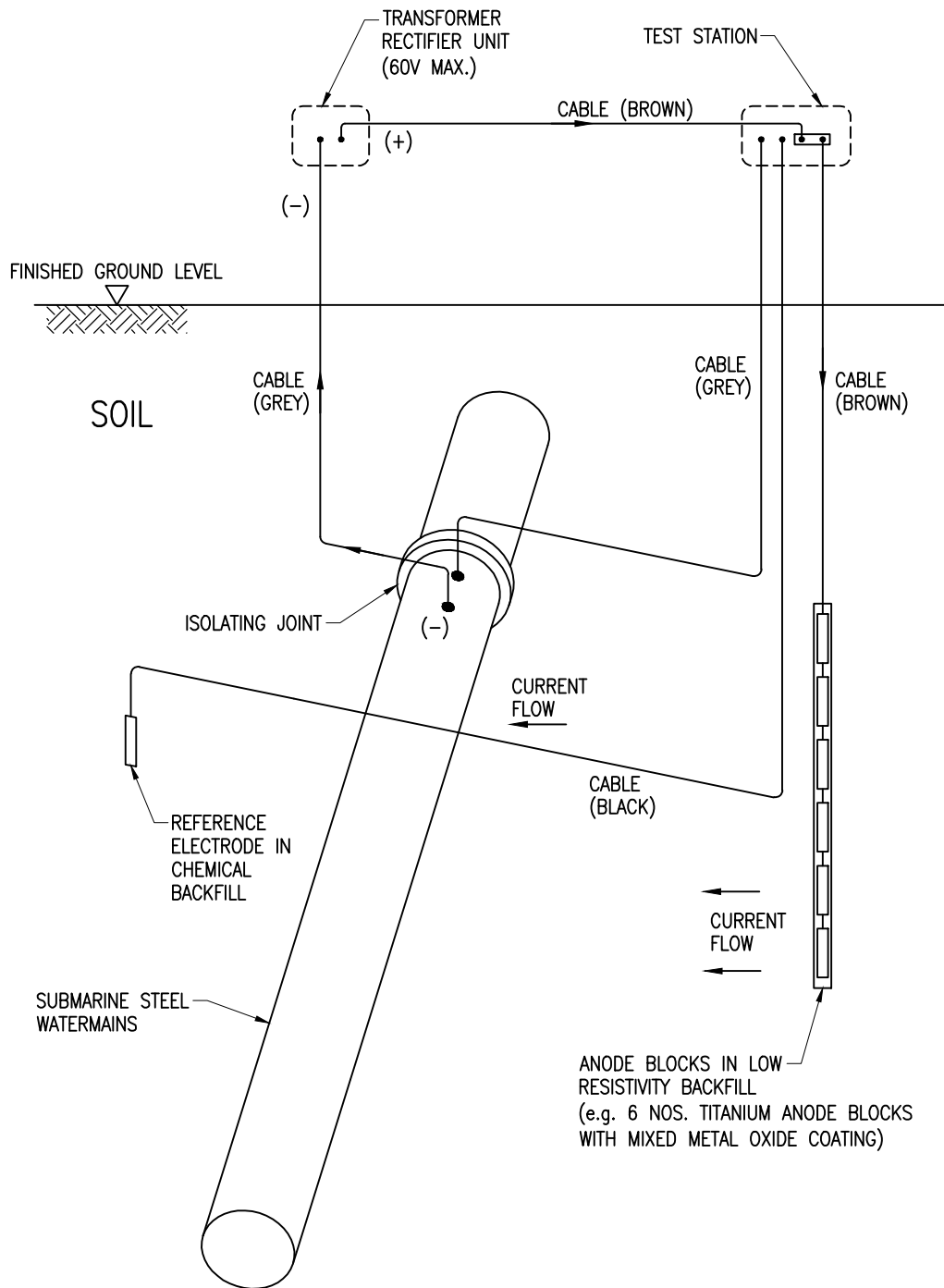

TYPICAL LAYOUT OF IMPRESSED CURRENT SYSTEM

CAD REF. : AP030401-A.dwg



CATHODIC PROTECTION SYSTEM

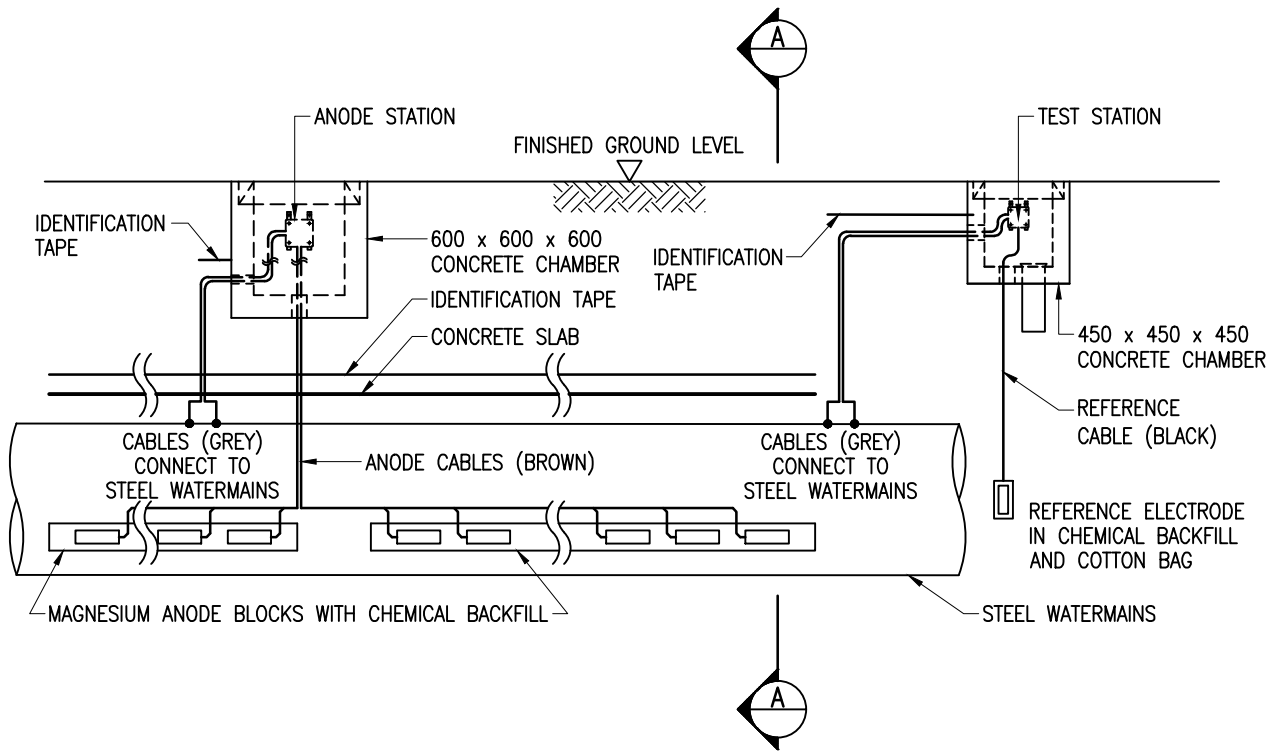

INSTALLATION DETAILS OF SACRIFICIAL ANODE

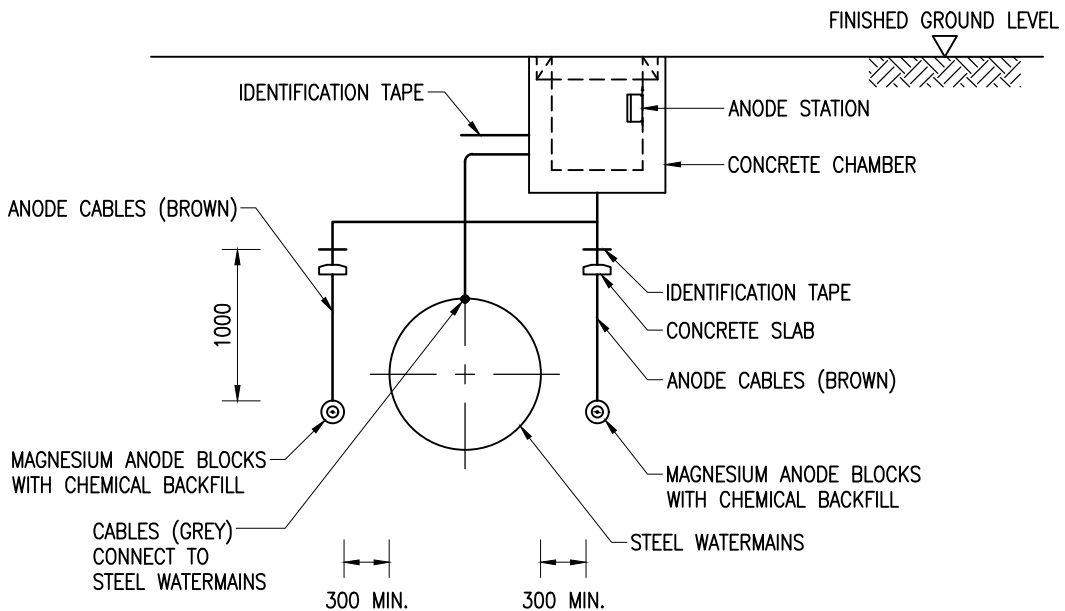

SECTION A - A

SACRIFICIAL ANODE CATHODIC PROTECTION FOR WATERMAINS ABOVE DN800 - GENERAL ARRANGEMENT

NOT TO SCALE

NOTES:

1. ALL DIMENSIONS ARE IN MILLIMETRES.
2. ALL CABLES SHALL BE XLPE/PVC OR PVC/PVC NON-ARMoured SINGLE CORE.

CAD REF. : AP030402-A.dwg



水務署
Water Supplies Department

CATHODIC PROTECTION SYSTEM

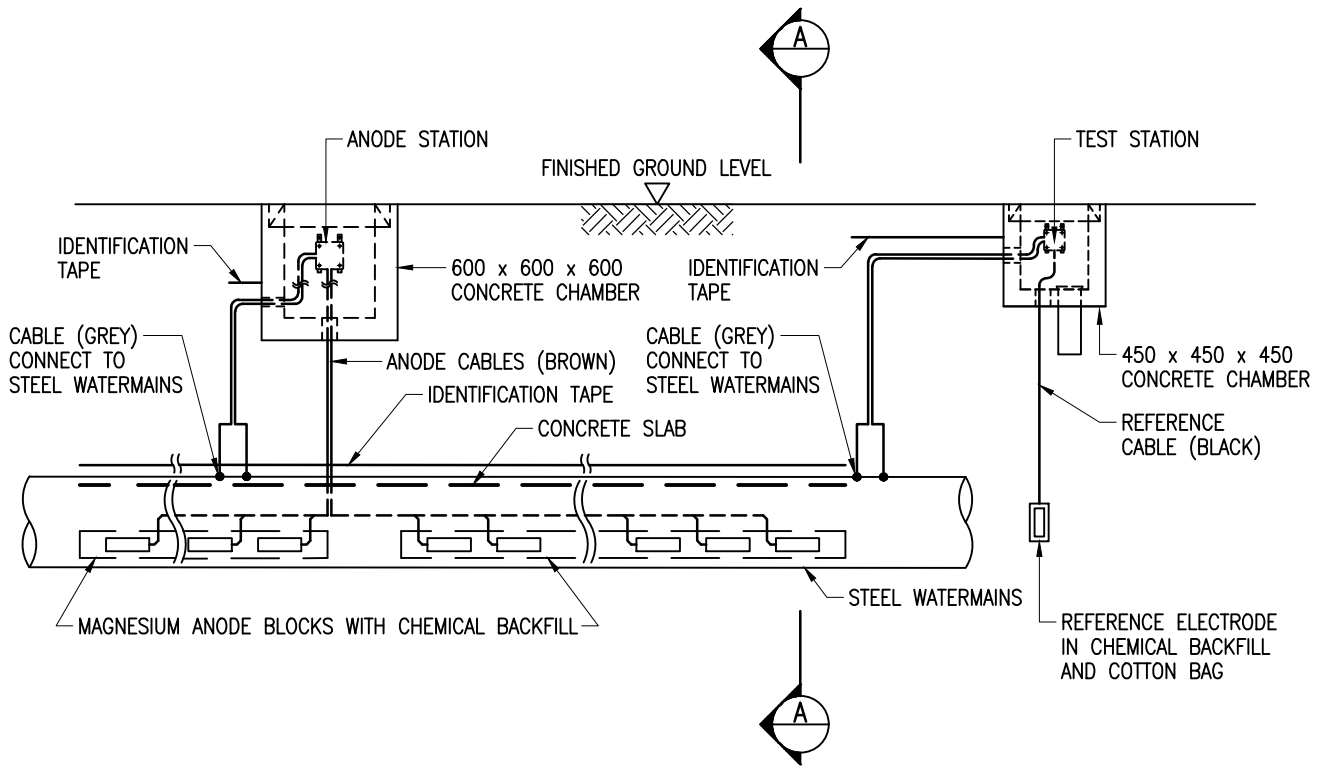

INSTALLATION DETAILS OF SACRIFICIAL ANODE

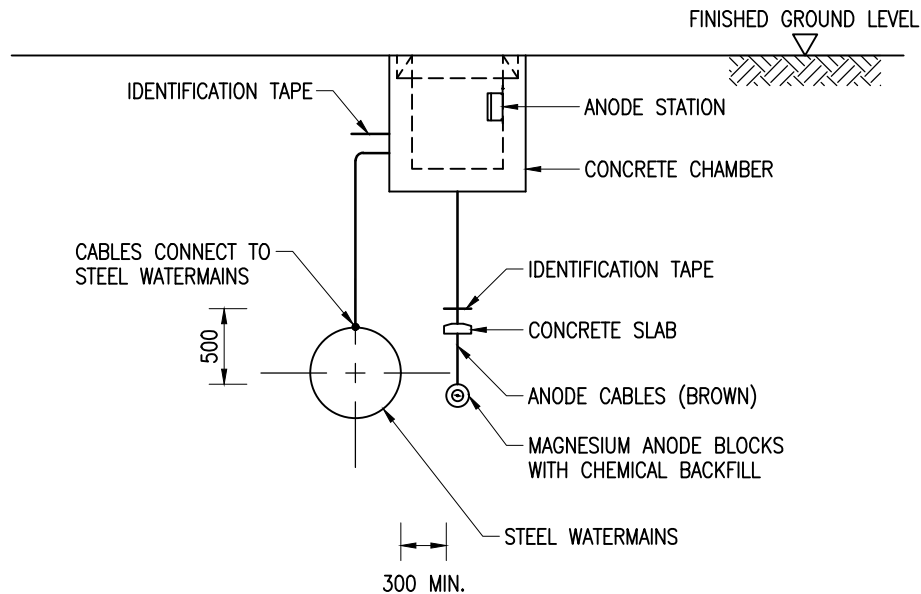

SECTION A - A

SACRIFICIAL ANODE CATHODIC PROTECTION FOR WATERMAINS DN800 AND BELOW - GENERAL ARRANGEMENT

NOT TO SCALE

NOTES:

1. ALL DIMENSIONS ARE IN MILLIMETRES.
2. ALL CABLES SHALL BE XLPE/PVC OR PVC/PVC NON-ARMOURED SINGLE CORE.

CAD REF. : AP030403-A.dwg



水務署

Water Supplies Department

CATHODIC PROTECTION SYSTEM

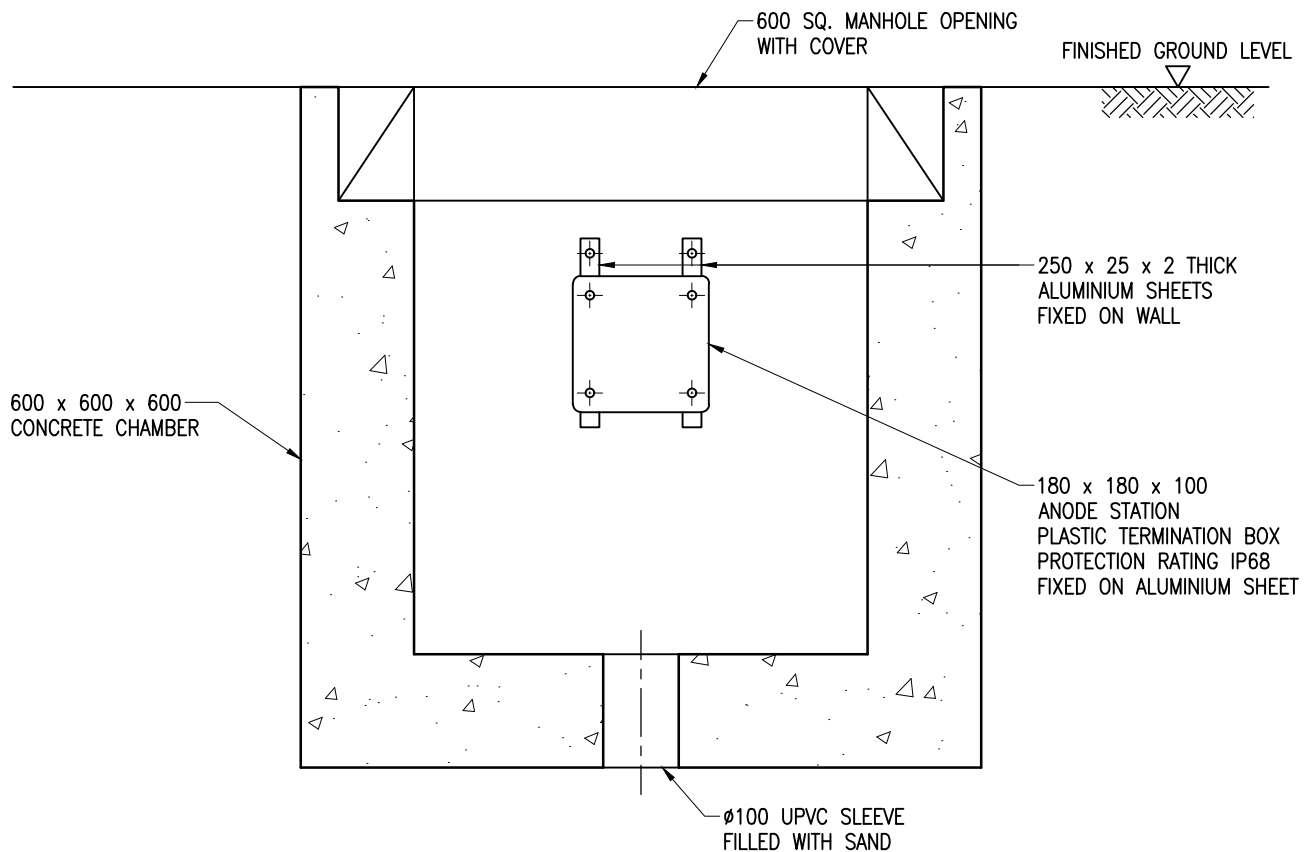

DETAILS OF ANODE STATION

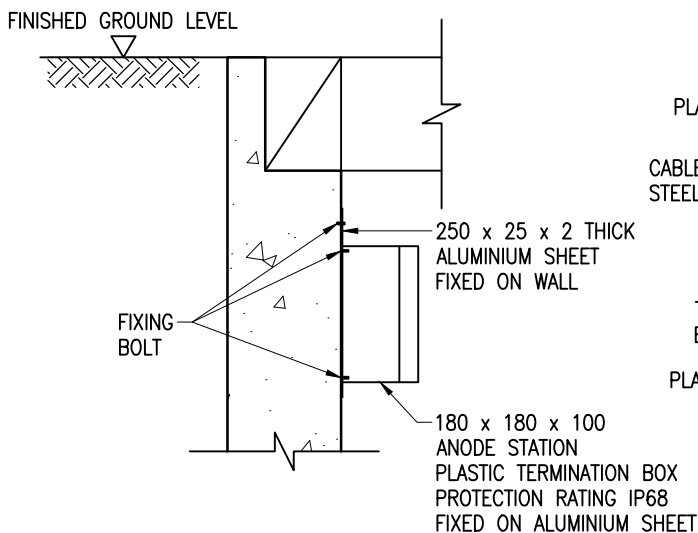

DETAILS OF ANODE STATION FIXING

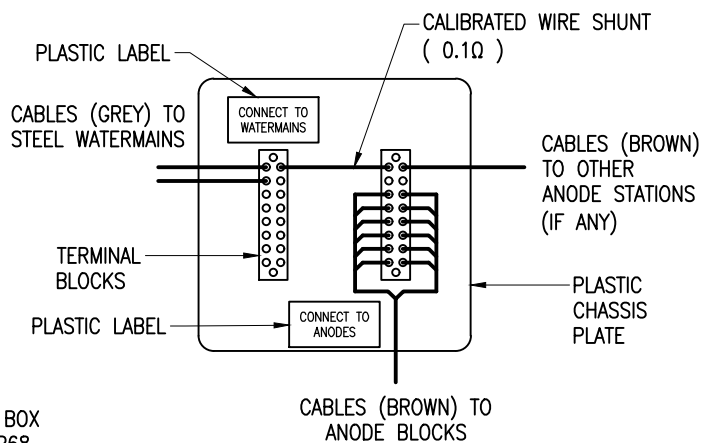

DETAILS OF TYPICAL ANODE STATION INTERIOR

SACRIFICIAL ANODE CATHODIC PROTECTION ANODE STATION – GENERAL ARRANGEMENT

NOT TO SCALE

NOTES:

1. ALL DIMENSIONS ARE IN MILLIMETRES.
2. ALL CABLES SHALL BE XLPE/PVC OR PVC/PVC NON-ARMoured SINGLE CORE.

CAD REF. : AP030404-A.dwg



水務署
Water Supplies Department

CATHODIC PROTECTION SYSTEM

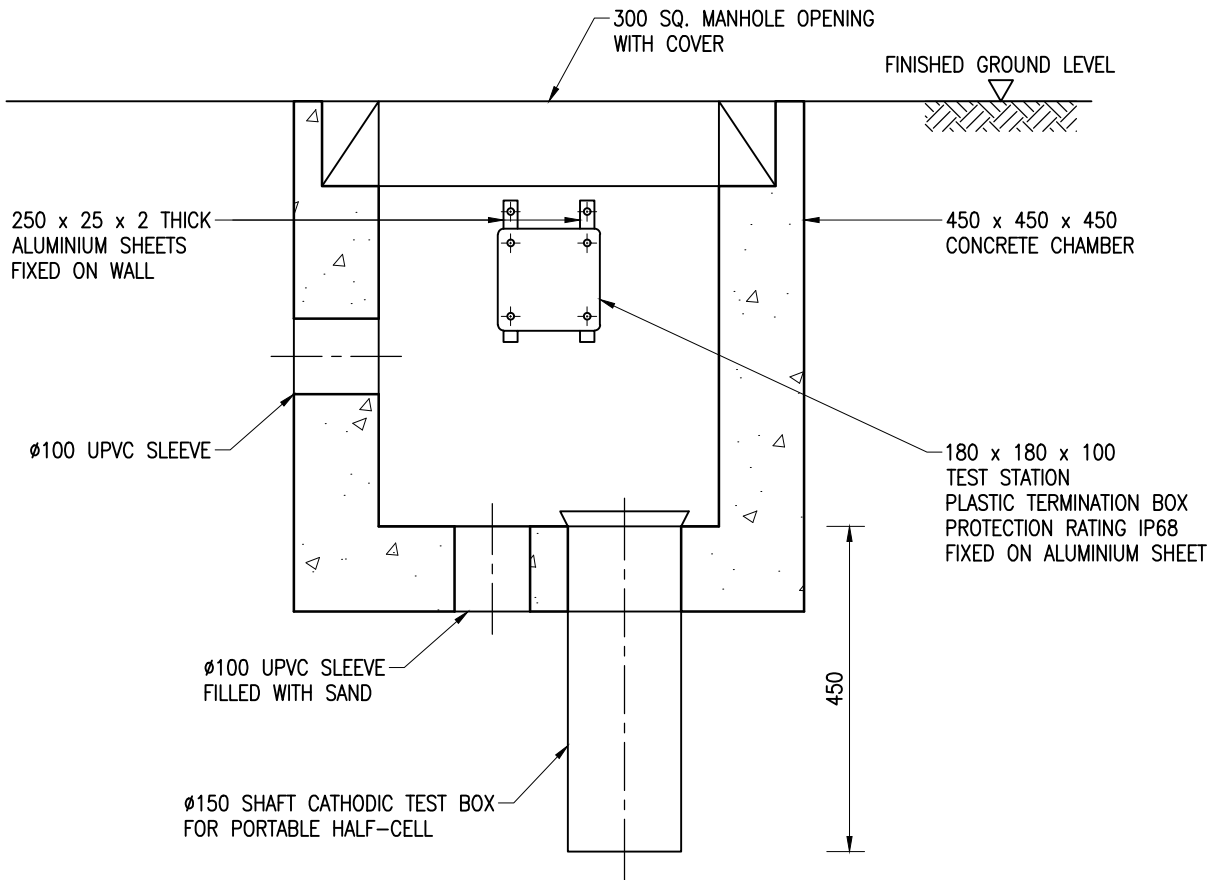

DETAILS OF TEST STATION

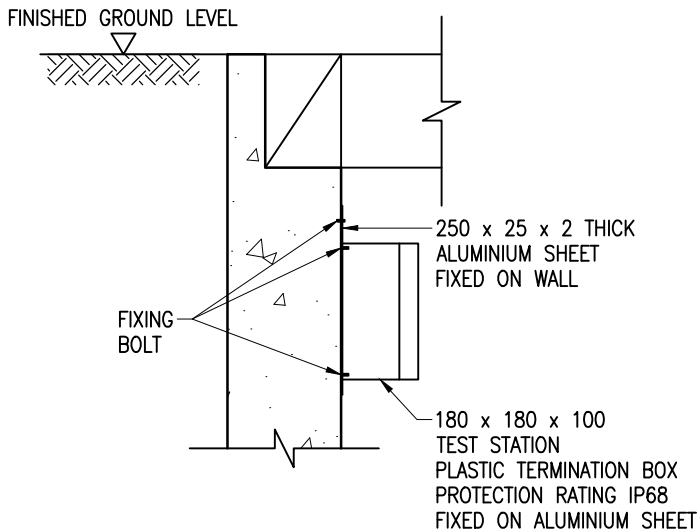

DETAILS OF TEST STATION FIXING

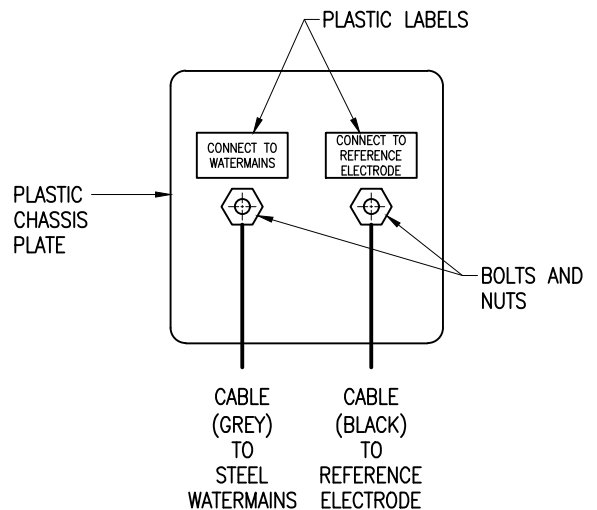

DETAILS OF TYPICAL TEST STATION INTERIOR

SACRIFICIAL ANODE CATHODIC PROTECTION TEST STATION – GENERAL ARRANGEMENT

NOT TO SCALE

NOTES:

1. ALL DIMENSIONS ARE IN MILLIMETRES.
2. ALL CABLES SHALL BE XLPE/PVC OR PVC/PVC NON-ARMOURED SINGLE CORE.

NOT USED

Amendment No. 1/2015



NOT USED

Amendment No. 1/2015



水務署

Water Supplies Department

INSTALLATION OF PEDESTAL AND SWAN NECK HYDRANTS

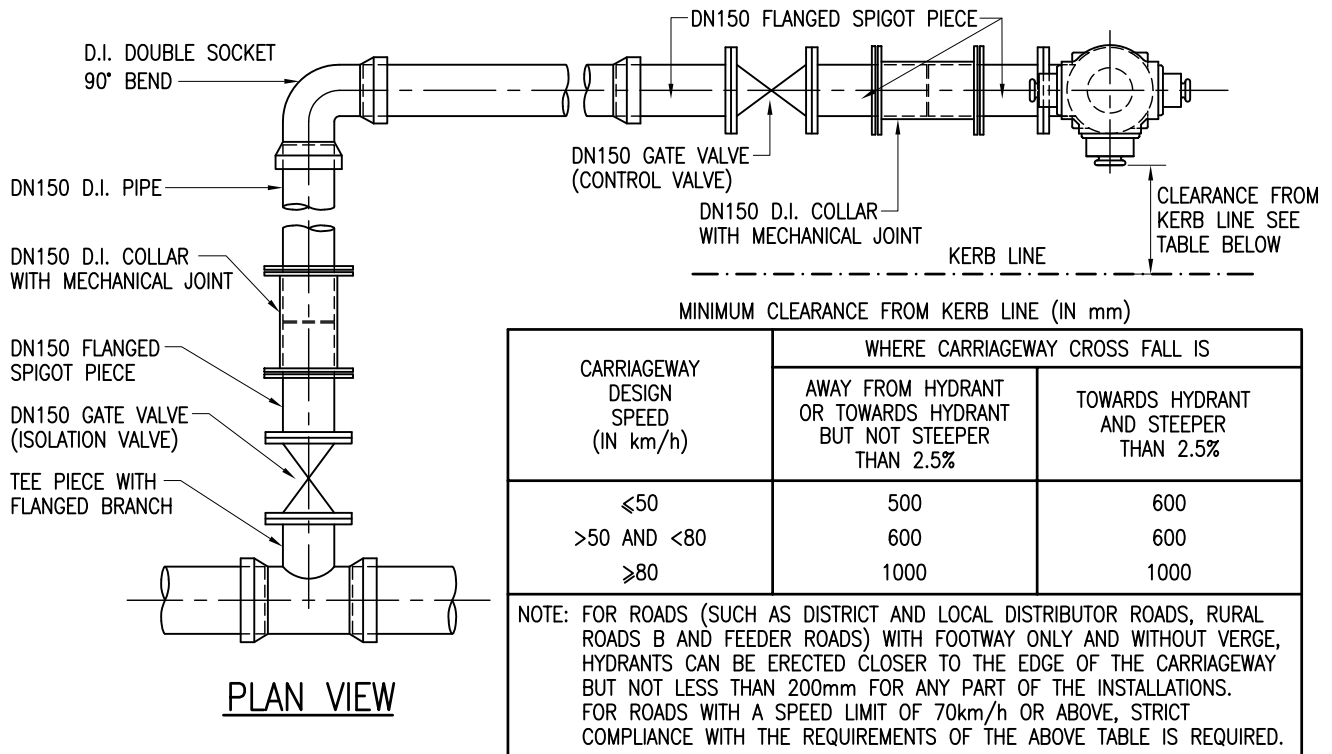

INSTALLATION OF PEDESTAL HYDRANT – Ø150mm DUCTILE IRON PIPES

EXTRACTED FROM STANDARD DRAWING WSD 1.17

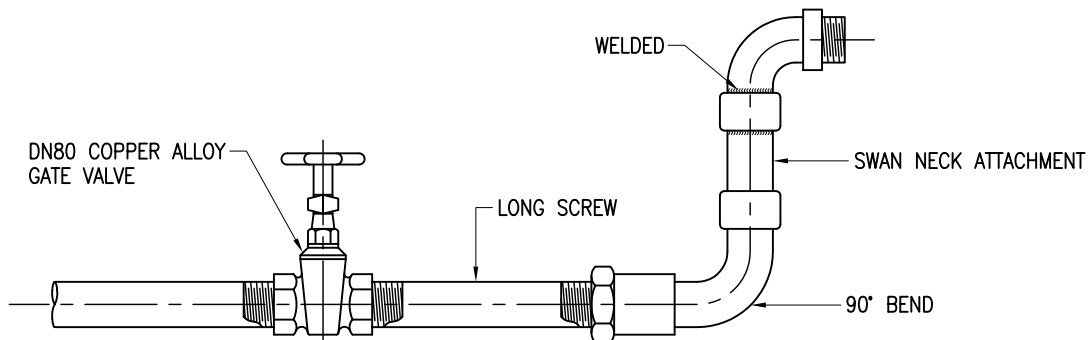

INSTALLATION OF Ø80mm SWAN NECK HYDRANT – Ø80mm GALVANISED IRON PIPES

FOR EXISTING SWAN NECK

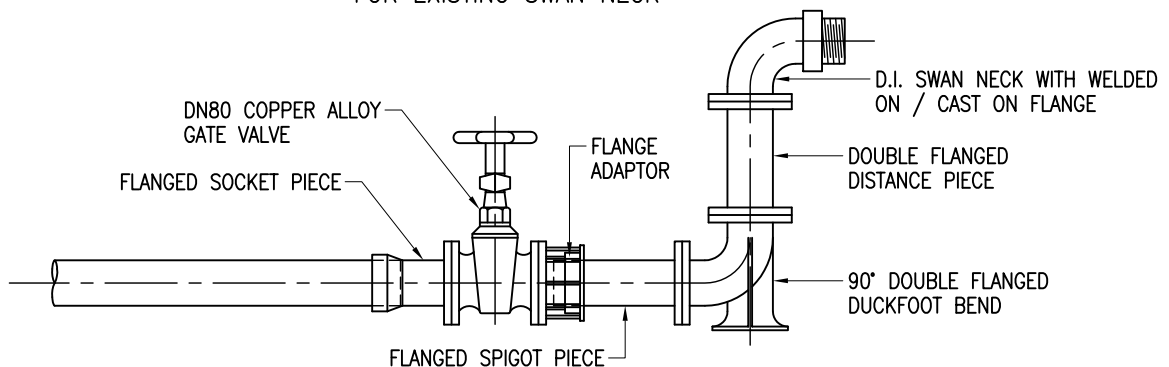

INSTALLATION OF Ø80mm SWAN NECK HYDRANT – Ø80mm DUCTILE IRON PIPES

FOR DN100 DUCTILE IRON PIPES, ADD A REDUCER IN FRONT OF GATE VALVE

WATER SUPPLIES DEPARTMENT
Notification Form for Shallow Covered Water Mains

From _____
Ref. _____ in _____
Tel. No. _____
Fax. No. _____
Date _____

To _____ CTO/DO
(Attn.: _____)
Your Ref. _____ In _____
dated _____ Fax. No. _____
Total pages _____

General information of Shallow Covered Water Mains (SCM)

1. SCM No. : _____
(assigned by DO/HQ in case of a newly laid or newly identified SCM unit)
2. Location : * Footpath/Carriageway/Verge/Cycle track/Others, please specify _____
at _____
(Number and name of street, estate or village)
_____ * HK
_____ KLN
(Place and District) _____ NT
Other specified details: _____
(e.g. Lamp post no. or PH no. etc)
3. Type : Fresh Salt
4. Condition : Newly Laid Abandoned Altered Existing Pipe
5. Date of laying : _____
6. Reference Drawing/File/Sketch No. : _____
7. MRP No. : _____

Details of protected SCM

Diameter : _____ *mm/inch Material : * DI/MS/PE/GI (Lined)/UPVC/ _____
(others, please specify)

Length : _____ m Crown Level : _____ m A.P.D. Cover : _____ m

Method of protection : By concrete surround By steel cover plates
 By R.C. slab By sheathing pipe By other method
(Please specify)

Remarks : _____

Checked by :

Engineer

/ /

For DO/HQ use only	
Date Received	
Date Recorded	
Recorded by	
Checked by	

* Delete whichever is inapplicable

Tick as appropriate

Note : This notification form should be forwarded to Drawing Office together with the relevant Drawing(s)/Sketch(es) showing the position of the SCM.
e.g. As-Built Drawing, WWO85 etc.

MAINS RECORDS SIGN CONVENTIONS AND DESIGNATIONS

SIGN CONVENTIONS

TYPE	LEGEND
MAINS	
FRESH/SALT WATER MAINS	
RAW/UNTREATED WATER MAINS/CONDUIT	
BEING LAID MAINS	
PROPOSED MAINS	
WASHOUT PIPE	
SLUDGE PIPE	
TREATED EFFLUENT MAINS	
WATER MAINS REQUIRE REGULAR FLUSHING	
PRIVATE MAINS (SEE NOTE 2)	
MAINS OF OTHER DEPARTMENTS (SEE NOTE 3)	
REPLACEMENT AND REHABILITATION MAINS	
PENDING HANDOVER TO WSD	
FIRE SERVICES	
PEDESTAL FIRE HYDRANT	
GROUND FIRE HYDRANT	
HEAVY DRAW-OFF FIRE HYDRANT	
SWAN NECK FIRE HYDRANT	
TWIN OUTLET SWAN NECK FIRE HYDRANT	
FIRE SERVICES CONNECTION	
VALVES	
BUTTERFLY VALVE	
SLUICE VALVE	
GATE VALVE	
STOP COCK	
SINGLE AIR VALVE	
DOUBLE AIR VALVE	
WASHOUT VALVE	
NON RETURN/REFLUX VALVE	
FLOW REGULATING VALVE	
NORMALLY CLOSED VALVE	
PRESSURE CONTROL/REDUCING/RELIEF VALVE	
FLAP VALVE	
OTHERS	
STANDPIPE	
VENTURI TUBE	
INSPECTION MANHOLE TEE	
AIR VALVE ON INSPECTION MANHOLE TEE	
INSPECTION MANHOLE	
WATER TUNNEL	
ESSENTIAL VALVE REFERENCE NUMBER	
LEAKAGE COLLECTION CHAMBER	
LEAK NOISE CORRELATION POINT	
CATHODIC PROTECTION POINT	
CHECK METER/FLOWMETER	
WASTE DETECTION METER	
DISTRICT METER WITH STRAINER	
FLOW MEASUREMENT CHAMBER FOR ULTRASONIC FLOW METER	
SHALLOW COVERED WATER MAINS	
CHANGE IN PIPE	
BLANK FLANGE/END CAP	
PIPES CONNECTED	
PIPES CROSS OVER	

- NOTES:**
- WSD MAINS INCLUDE :
 - MAINS LAID AND MAINTAINED BY WSD.
 - MAINS LAID BY OTHER DEPARTMENTS OR PRIVATE PARTIES BUT MAINTAINED BY WSD AT WSD'S COST.
 - PRIVATE MAINS INCLUDE MAINS IN PRIVATE ROADS, PRIVATE HOUSING ESTATES, ETC. NOT MAINTAINED BY WSD.
 - MAINS OF OTHER DEPARTMENTS INCLUDE MAINS LAID BY OTHER GOVERNMENT DEPARTMENTS NOT MAINTAINED BY WSD.
 - EXTRACTED FROM DRAWING NO. SK3988B.

ABBREVIATIONS

PIPE MATERIALS

AC	ASBESTOS CEMENT
CI	CAST IRON
CONC	CONCRETE
COPP	COPPER ALLOY
DI	DUCTILE IRON
GI	GALVANIZED IRON
GIL	LINED GALVANIZED IRON
GRP	GLASS FIBRE REINFORCED PLASTIC
HDPE	HIGH DENSITY POLYETHYLENE
MDPE	MEDIUM DENSITY POLYETHYLENE
PE	POLYETHYLENE
GMS	GALVANIZED MILD STEEL
MS	MILD STEEL
S	STEEL
UPVC	UNPLASTICISED POLYVINYL CHLORIDE

REHABILITATION METHODS

RA	CURED IN PLACE PIPE (CIPP)
RB	CLOSE FIT ("FOLD AND FORM" SYSTEM)
RC	PIPE BURSTING
RD	SLIP LINING/SLIP INSERTION
RE	CLOSE FIT ("SWAGELINING" SYSTEM)
RF	FIBRE REINFORCED PLASTIC (FRP) SYSTEM
RG	INTERNAL LINING REPAIRED
RH	EXTERNAL COATING REPAIRED

DESIGNATIONS

- '450DI99' DESIGNATES 450mm DIAMETER DUCTILE IRON PIPE LAID IN 1999.
- '600S03(E)' DESIGNATES 600mm DIAMETER STEEL PIPE LAID IN 2003 (ENTRUSTMENT).
- '600DI97(W10582/2B)' DESIGNATES 600mm DIAMETER DUCTILE IRON PIPE LAID IN 1997 WITH DRAWING REFERENCE (W10582/2B).
- '150DI04WO, 150DI04F, 150DI04OF' DESIGNATES 150mm DIAMETER, DUCTILE IRON PIPE MATERIAL, LAID IN 2004, OF TYPE WASHOUT PIPE, FIRE SERVICE MAINS AND OVERFLOW PIPE RESPECTIVELY.
- '150CIRA04' DESIGNATES 150mm DIAMETER CAST IRON PIPE REHABILITATED IN 2004 BY CURED IN PLACE PIPE METHOD (SEE ABBREVIATIONS).
- '600S03(L), 600S03(DRY), 600S03(PC)' DESIGNATES 600mm DIAMETER, STEEL PIPE MATERIAL, LAID IN 2003 WITH LEAKAGE COLLECTION SYSTEM, DRY MAINS AND PENDING COMMISSION MAINS RESPECTIVELY.
- '80PE09(TM)' DESIGNATES 80mm DIAMETER, POLYETHYLENE PIPE MATERIAL, LAID IN 2009, TEMPORARY MAINS FOR FLUSHING.

CAD REF. : AP030900.dwg

DETAILS OF ARRANGEMENT FOR FLUSHING AT DEAD-END MAINS ADJACENT TO DISTRICT BOUNDARY VALVE

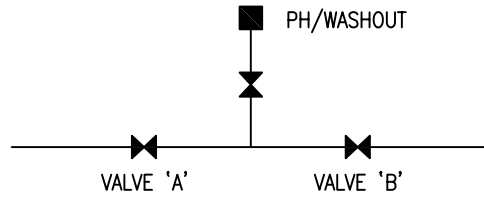

OPTION 1

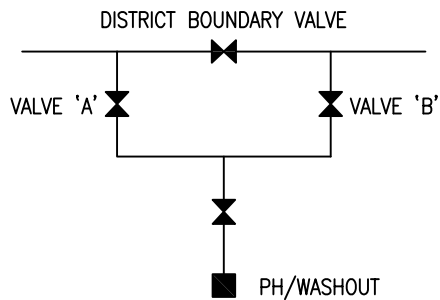

OPTION 2

NOTE :

1. UNDER NORMAL OPERATION CONDITION, ONLY VALVE 'A' OR VALVE 'B' ARE OPENED.

Advantages and Disadvantages of Various Methods of Rehabilitation of Water Mains

Type of Rehabilitation Method	Advantages	Disadvantages
Close Fit Lining	<ul style="list-style-type: none"> ● Commonly used for structural rehabilitation of small to medium size pipes with PE liners which are comparatively easy for maintenance. ● “Fold and Form” system - can accommodate a size ranging from DN 600 to DN 900 for semi-structural lining. Particularly applicable when the available working space is limited, because the lining can be spliced in short segments on site before folding. 	<ul style="list-style-type: none"> ● “Swagelining” system - requires a long stick of lining to be butt welded and laid behind the access pit prior to insertion. Sufficient working space should be allowed for welding before swaging and insertion. ● “Fold and Form” system – can only allow for a maximum size normally up to DN 400 for fully-structural lining. Lining is normally delivered on drums held by drum trailers. Sufficient lead time should be allowed for the procurement and delivery of lining. ● Semi-structural rehabilitation of cement-lined steel pipe should not be adopted, unless the cement lining can be completely removed to avoid the creation of ridges in the lining.
Cured-in-place Pipe (CIPP)	<ul style="list-style-type: none"> ● Able to be tailor-made in factory to suit the diameter of the host pipe to be rehabilitated. ● Able to accommodate bends within the host pipe up to 22.5°. ● Uses a lining thinner than that of Close Fit Lining for rehabilitating pipes with the same size. 	<ul style="list-style-type: none"> ● Increasing difficulty in installation of CIPP lining with increasing diameter of the host pipe. ● Requires high quality control for resin mixing, impregnation, installation and curing. ● Requires proprietary sealing system to protect the interface between the CIPP lining and the host pipe. ● Less easier to accommodate variation in the diameter of the host pipe. ● More difficult and complicated for maintenance as compared with standard PE liners. Rarely used nowadays.

Type of Rehabilitation Method	Advantages	Disadvantages
Sliplining	<ul style="list-style-type: none"> ● A relatively simple and efficient rehabilitation technique for long runs with few connections. ● Does not require a long stick as pipe welding can be carried out on site. ● Able to accommodate minor variation in the diameter of the host pipe (as the sliplining does not need to be “close fit” with the host pipe). ● As an alternative to Close Fit Lining for structural rehabilitation of large diameter pipes with PE liners. 	<ul style="list-style-type: none"> ● Less easier to accommodate bends. ● Requires adequate clearance between the sliplined pipe and host pipe to allow for smooth insertion, thus leading to significant reduction in cross-sectional area of the host pipe and hydraulic capacity.
Internal FRP Layer Lining & External FRP Layer Wrap	<ul style="list-style-type: none"> ● A relatively quick rehabilitation technique to be carried out manually, with minimal impact to the host pipe. ● Requires a small site access to the host pipe (for internal FRP layer lining only). 	<ul style="list-style-type: none"> ● For use in large diameter steel pipes only, with localised defects and weak spots in the host pipe to be repaired before application of the lining/wrap. ● Requires high quality control for application of lining/wrap. ● More difficult and complicated for maintenance as compared with normal steel pipe coated with epoxy lining.
Automatic Internal Coating Replacement	<ul style="list-style-type: none"> ● A relatively quick rehabilitation technique, where man-entry into the host pipe is not required. ● Require a small site access to the host pipe. 	<ul style="list-style-type: none"> ● For use in steel pipes only, with localised defects and weak spots in the host pipe to be repaired before application of the lining.
Manual Internal Coating Replacement	<ul style="list-style-type: none"> ● A relatively economical and reliable rehabilitation technique. ● Does not require installation of sealing system at pipe ends. ● Structural rehabilitation of large diameter steel pipes can be achieved by patching up localised weak spots with steel plate before applying epoxy coating which is comparatively easy for maintenance. 	<ul style="list-style-type: none"> ● For use in steel pipes only, with localised defects and weak spots in host pipe to be repaired before application of lining. ● Requires man-entry into the pipeline, and cleaning and sand blasting to ensure good adhesion of epoxy/polyurethane to the host pipe. ● Requires a longer time for the application and curing of epoxy lining.

SCHEMATIC ARRANGEMENT FOR CONNECTING PIPE REHABILITATED BY CLOSE FIT LINING / SLIPLINING TO EXISTING / NEW PIPE

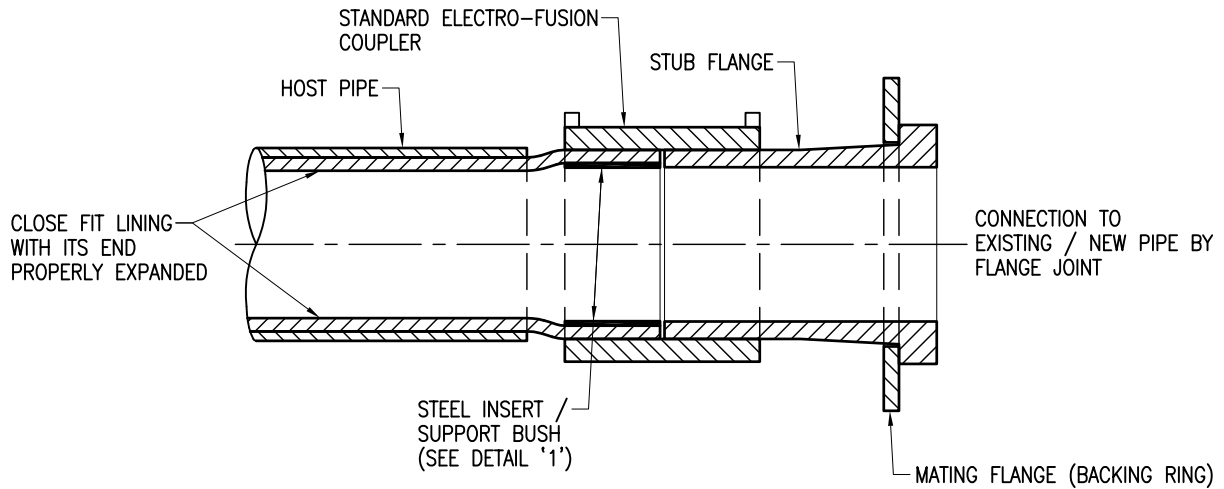

METHOD 1 : USING STANDARD ELECTRO-FUSION COUPLER
(FOR CLOSE FIT LINING)

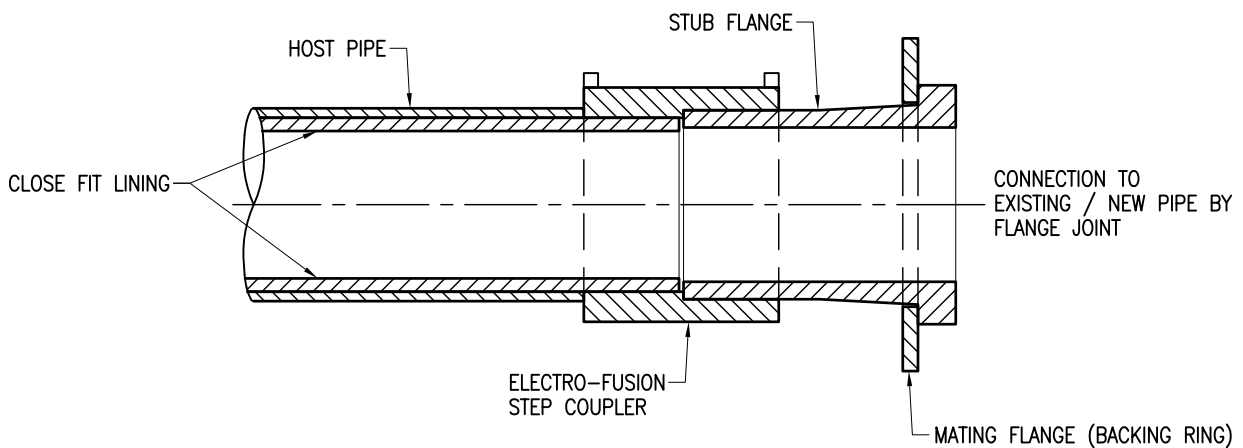

METHOD 2 : USING ELECTRO-FUSION STEP COUPLER
(FOR CLOSE FIT LINING)

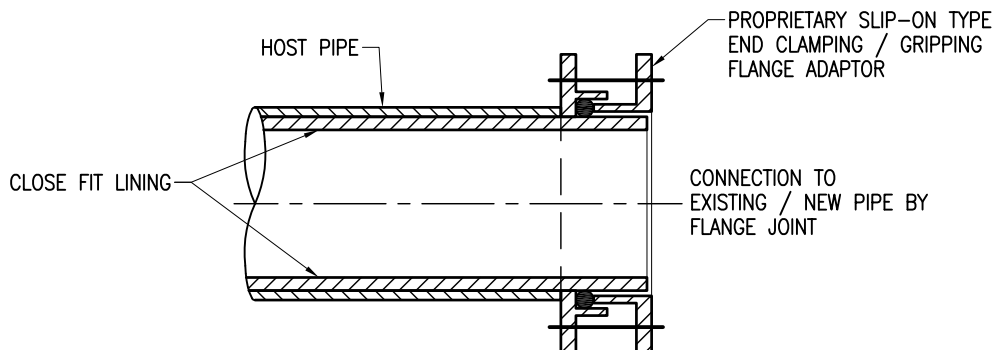

METHOD 3 : USING PROPRIETARY FLANGE ADAPTOR
(FOR CLOSE FIT LINING)

SCHEMATIC ARRANGEMENT FOR CONNECTING PIPE REHABILITATED BY CLOSE FIT LINING / SLIPLINING TO EXISTING / NEW PIPE

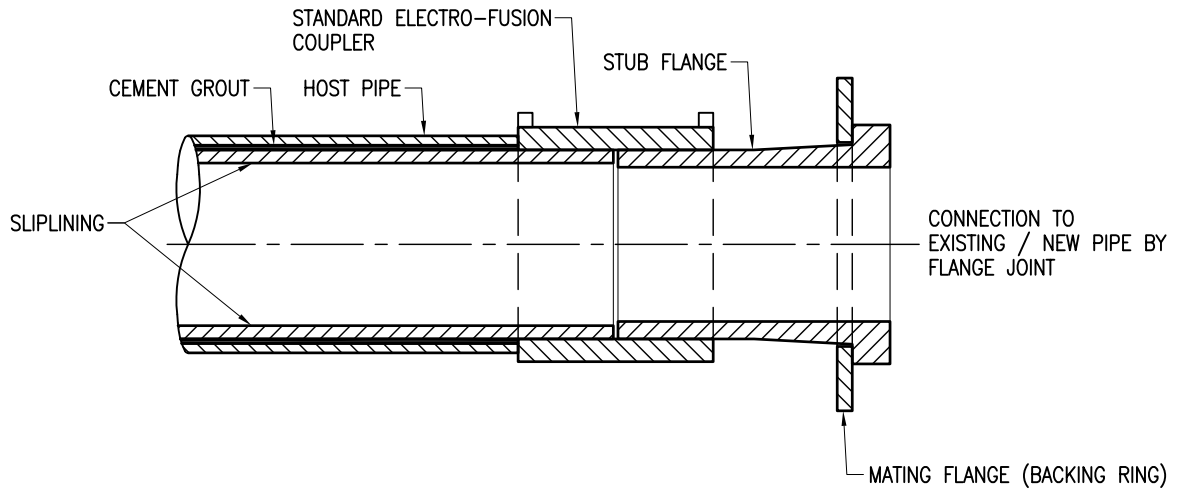

METHOD 4 : USING STANDARD ELECTRO-FUSION COUPLER (FOR SLIPLINING)

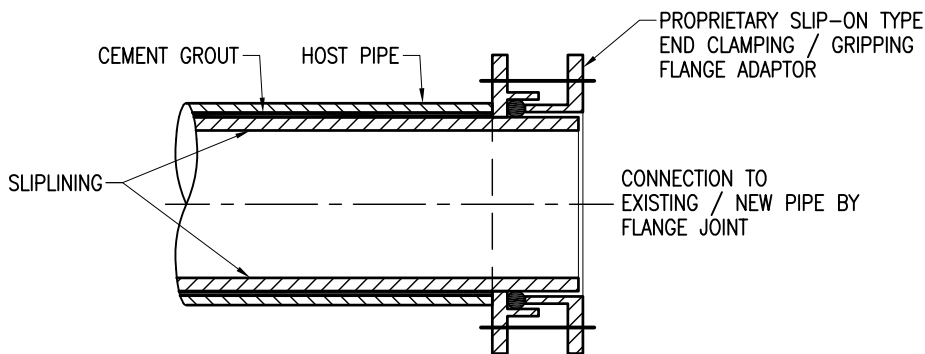

METHOD 5 : USING PROPRIETARY FLANGE ADAPTOR (FOR SLIPLINING)

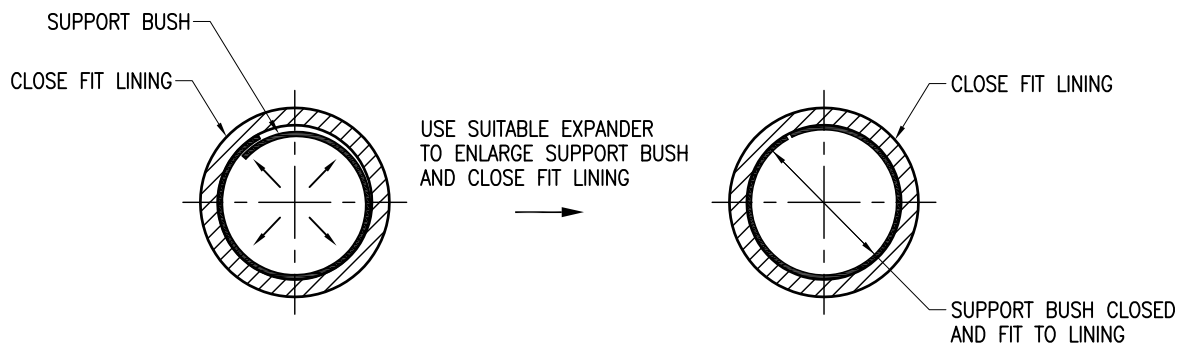

DETAIL '1'

INSTALLATION OF SUPPORT BUSH AT END OF CLOSE FIT LINING

SCHEMATIC ARRANGEMENT FOR CONNECTING PIPE REHABILITATED BY CURED-IN-PLACE PIPE (CIPP) METHOD TO EXISTING / NEW PIPE

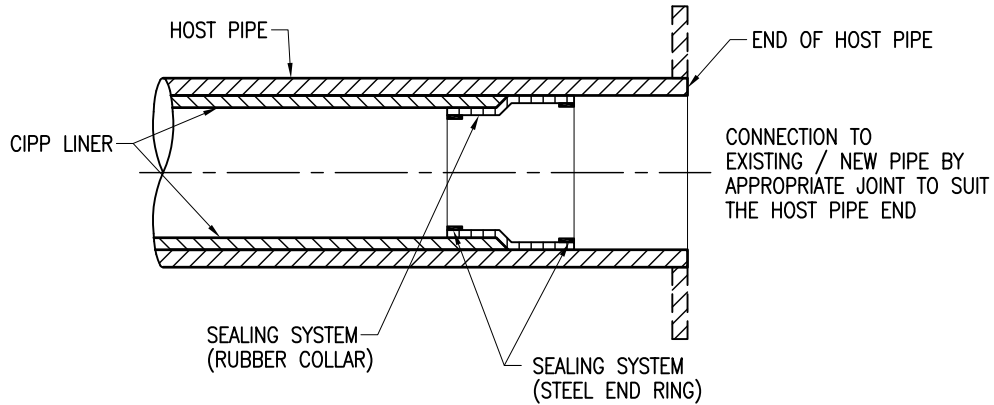

METHOD 1 : INSTALLATION OF SEALING SYSTEM WITHIN HOST PIPE

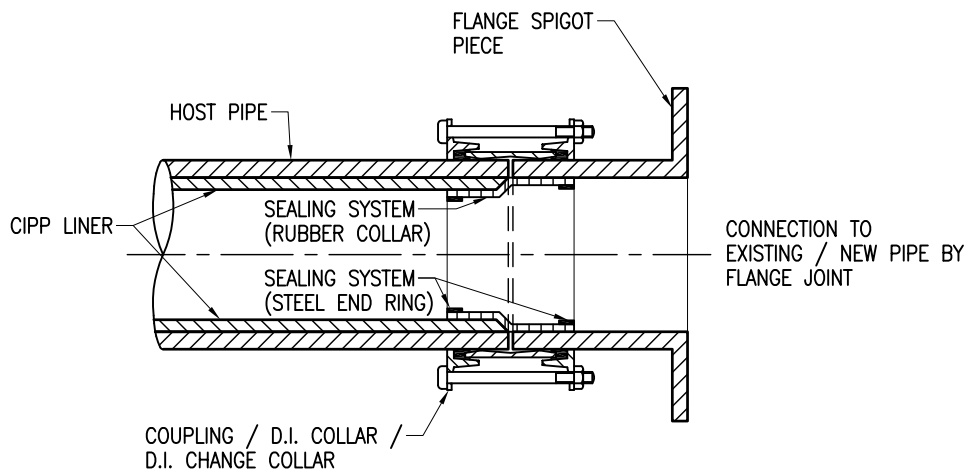

METHOD 2 : INSTALLATION OF SEALING SYSTEM AT END OF HOST PIPE

SCHEMATIC ARRANGEMENT FOR INSTALLING SEALING SYSTEM FOR EXTERNAL FIBRE REINFORCED POLYMER (FRP) LAYER WRAP

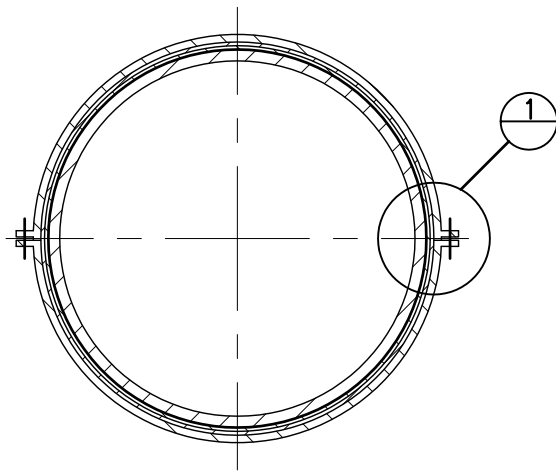

SECTION A - A

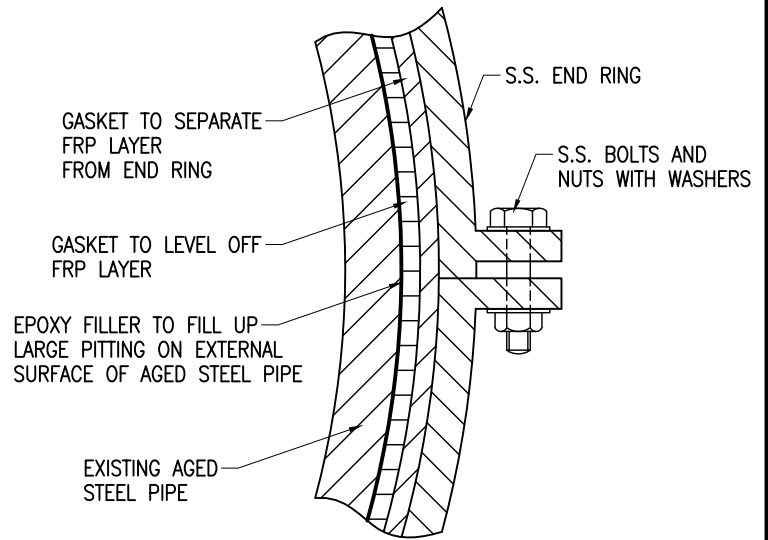

DETAIL '1'

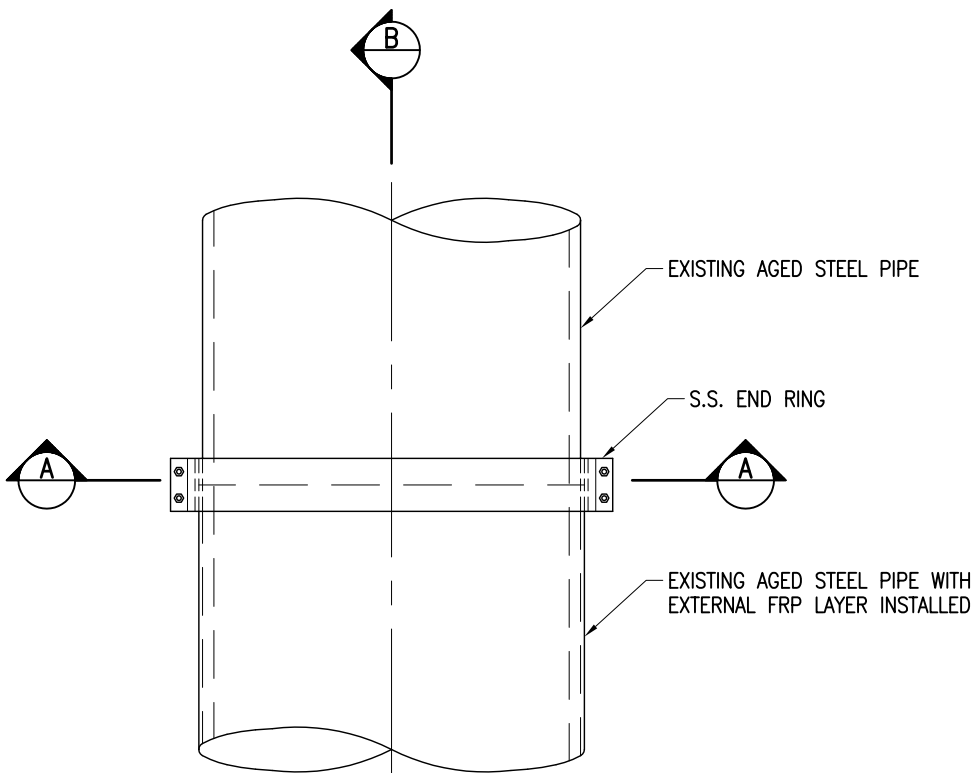

PLAN

SCHEMATIC ARRANGEMENT FOR INSTALLING SEALING SYSTEM FOR EXTERNAL FIBRE REINFORCED POLYMER (FRP) LAYER WRAP

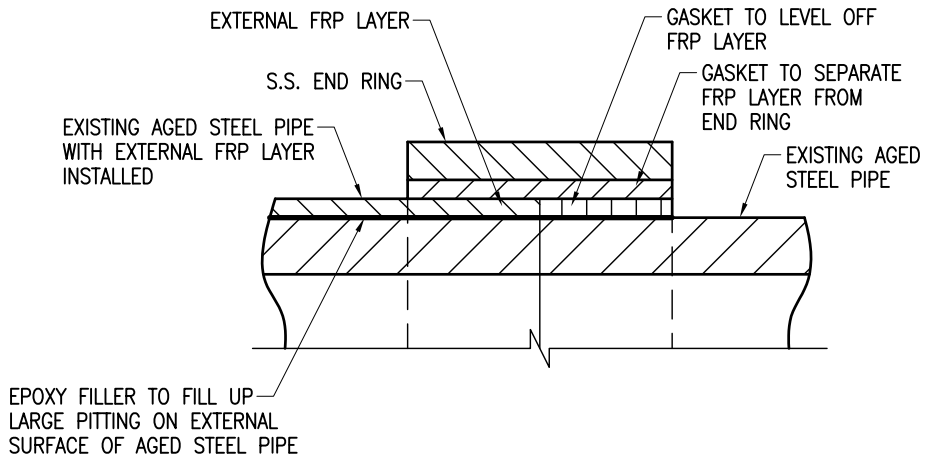

DETAIL '2'

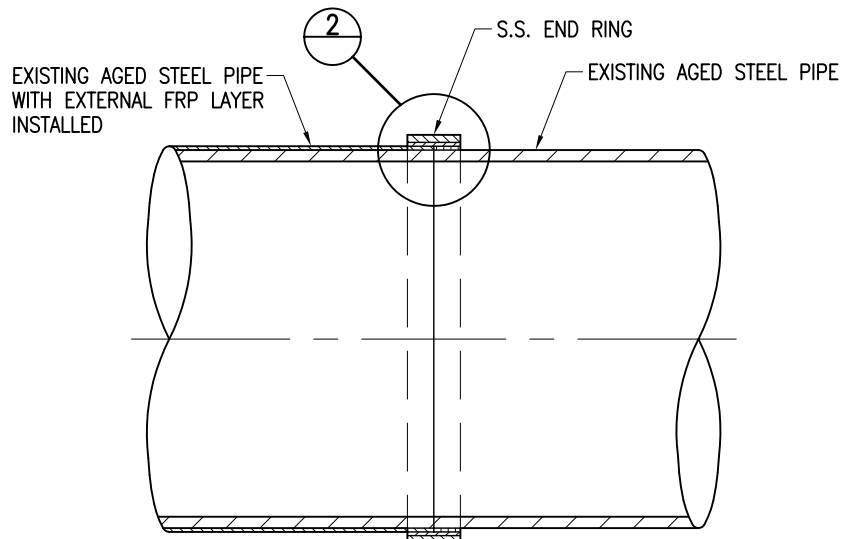

SECTION B - B

REPAIR OF DAMAGED PIPE REHABILITATED BY CURED-IN-PLACE PIPE (CIPP) METHOD

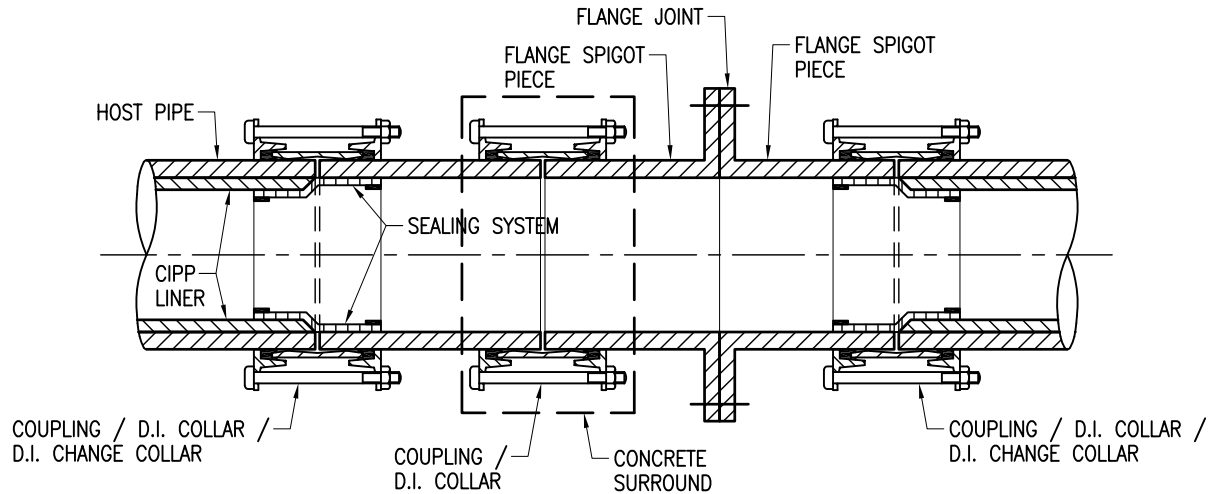

METHOD 1 : FOR REPAIR OF ASBESTOS CEMENT / CAST IRON / DUCTILE IRON OR STEEL PIPE FROM DN300 TO DN600

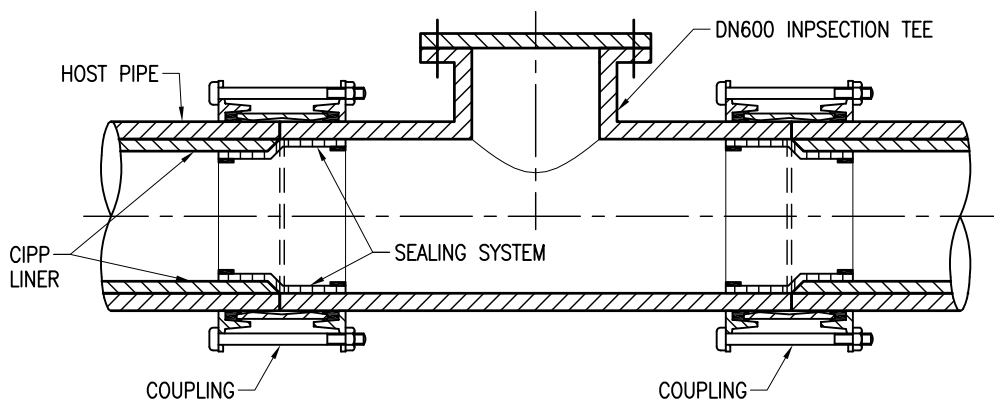

METHOD 2 : FOR REPAIR OF STEEL PIPE FROM DN700 OR ABOVE

REPAIR OF DAMAGED PIPE REHABILITATED BY CURED-IN-PLACE PIPE (CIPP) METHOD

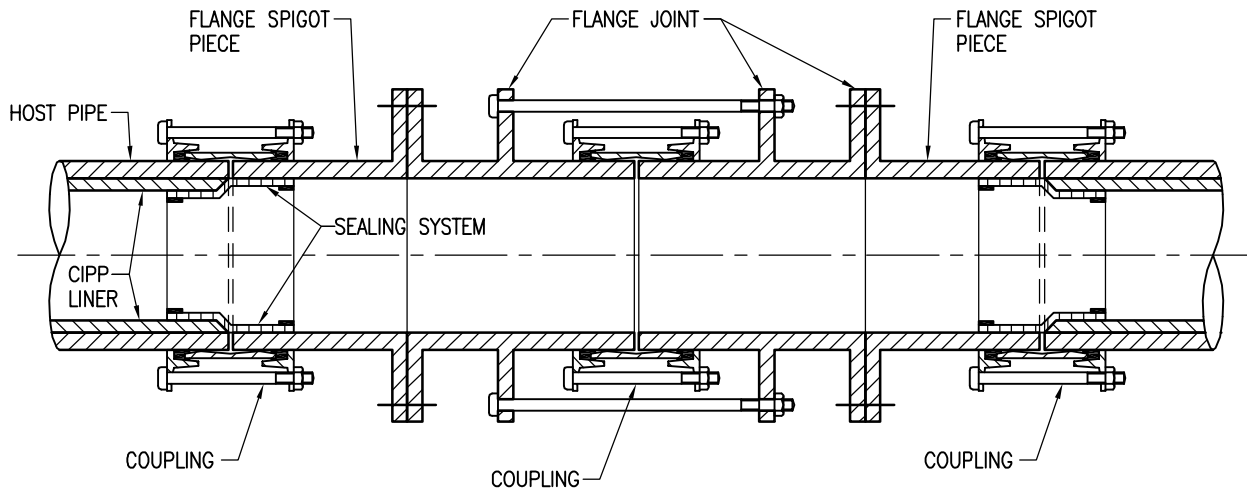

METHOD 3 : FOR REPAIR OF STEEL PIPE
FROM DN300 TO DN600

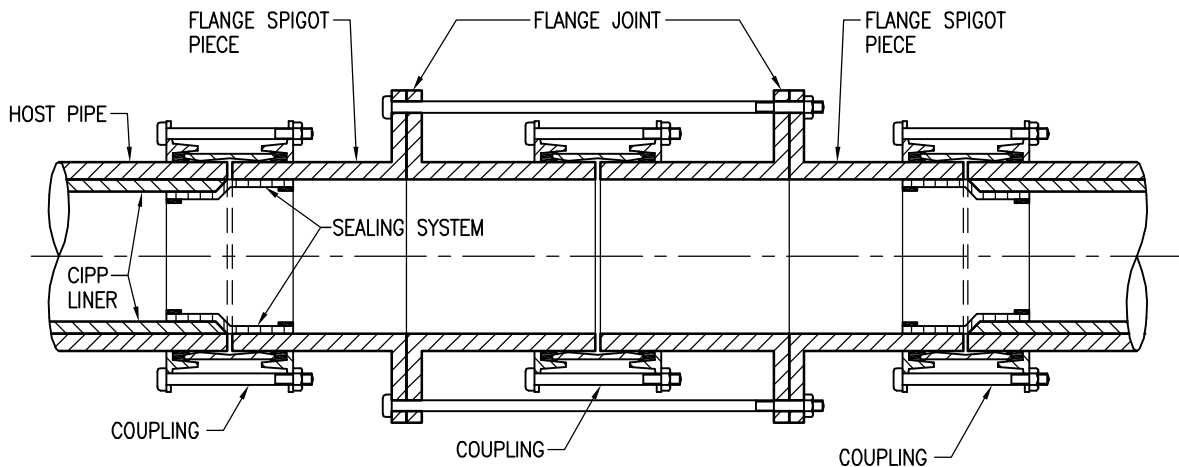

METHOD 4 : FOR REPAIR OF STEEL PIPE
FROM DN300 TO DN600

NOTES :

1. METHOD 1 INVOLVES THE USE OF STANDARD FITTINGS ONLY. IT IS IN GENERAL PREFERABLE TO METHODS 3 AND 4, PROVIDED THAT SUFFICIENT TIME IS AVAILABLE FOR THE LAYING AND HARDENING OF CONCRETE SURROUND BEFORE RESUMING WATER SUPPLY.
2. METHODS 3 AND 4 ARE TO BE USED UNDER SPECIAL CIRCUMSTANCES FOR SPEEDING UP THE REPAIR PROCESS, BEARING IN MIND THAT THE USE OF TAILOR-MADE FITTINGS OR LONG TIGHTENING BOLTS IS REQUIRED.

PROCEDURE FOR REPAIR OF PIPE REHABILITATED BY INTERNAL FIBRE REINFORCED POLYMER (FRP) LAYER LINING

1 WELD STEEL PLATE ON DAMAGED AREA

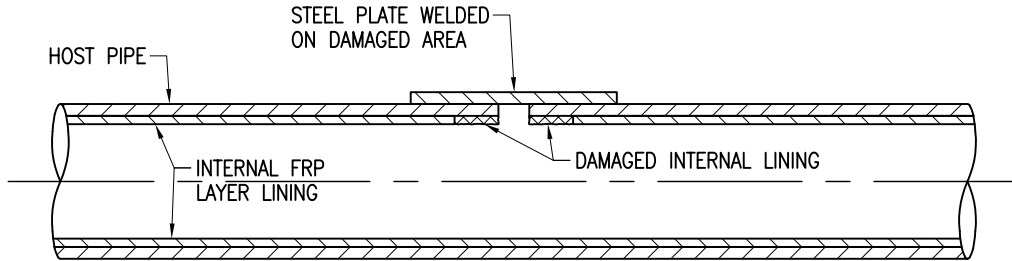

2 CUT DAMAGED LINING, APPLY BITUMEN PAINT AND PREPARE TWO WIDE SLOTS

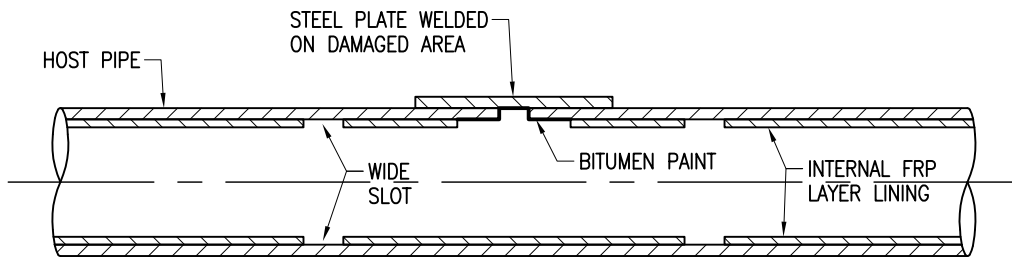

3 INSTALL TEMPORARY SEALING SYSTEM

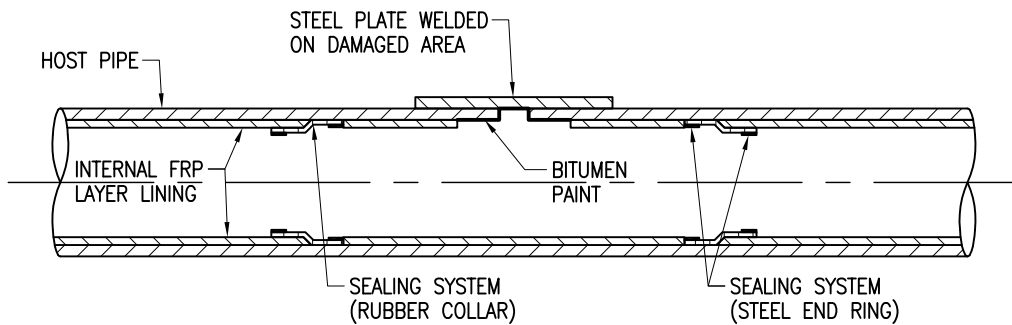

4 PERMANENT REPAIR OF DAMAGED INTERNAL FRP LAYER LINING

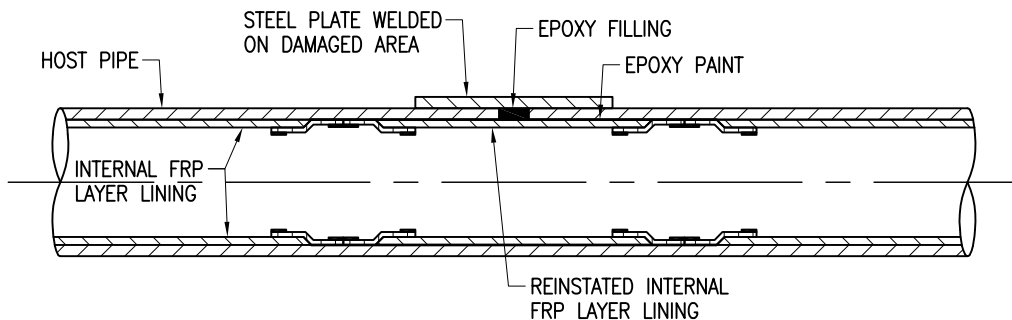

PROCEDURE FOR REPAIR OF PIPE REHABILITATED BY EXTERNAL FIBRE REINFORCED POLYMER (FRP) LAYER WRAP

1 IDENTIFY AND EXPOSE DAMAGED AREA

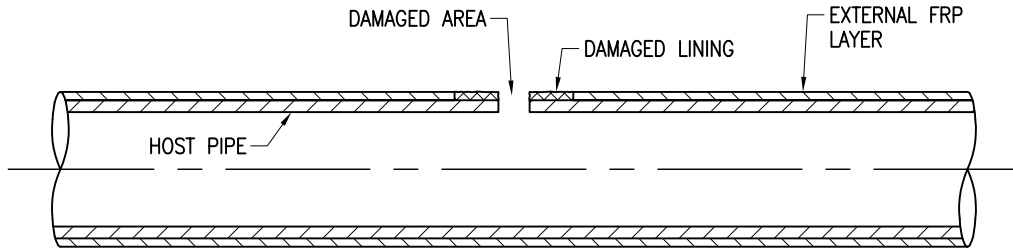

2 WELD STEEL PLATE ON DAMAGED AREA AND CUT BACK DAMAGED LINING

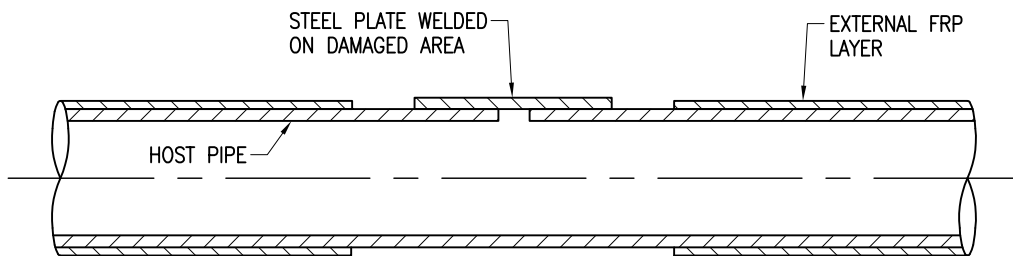

3 FILL UP EXTERNAL UNEVEN SURFACE BY EPOXY

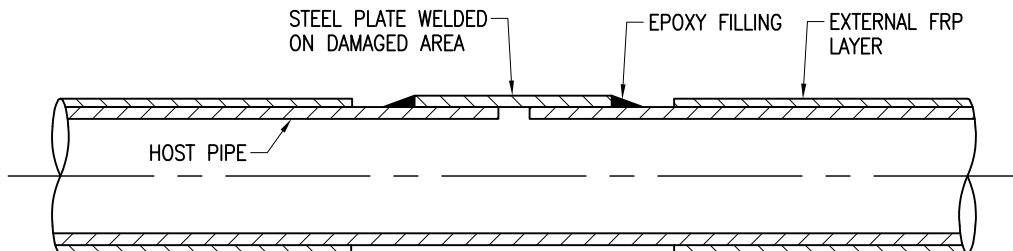

4 REPAIR DAMAGED EXTERNAL FRP LAYER

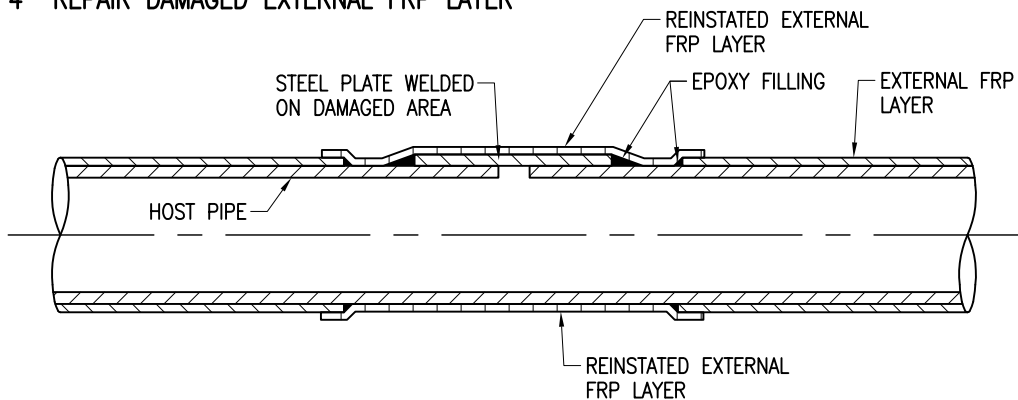

PROCEDURE FOR INSTALLATION OF PRE-FABRICATED FITTING ON PIPE REHABILITATED BY INTERNAL FIBRE REINFORCED POLYMER (FRP) LAYER LINING

1 CUT EXISTING REHABILITATED PIPE FOR INSTALLATION OF PRE-FABRICATED FITTING

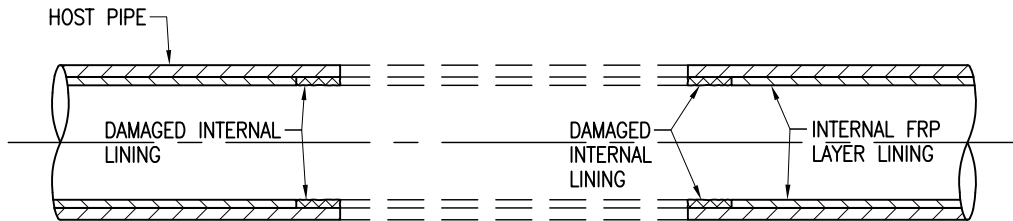

2 INSTALL PRE-FABRICATED FITTING

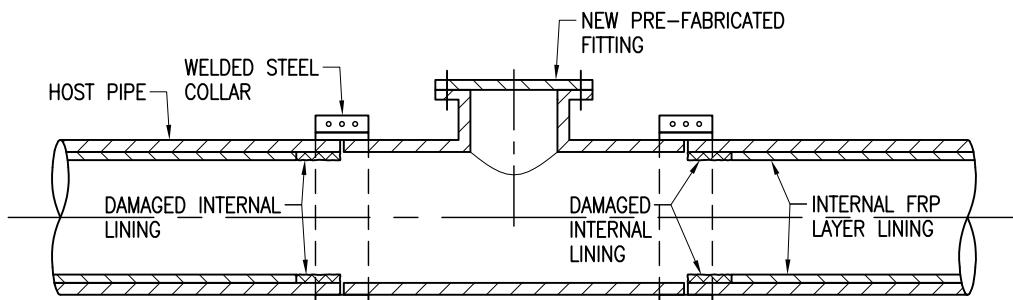

3 CUT BACK DAMAGED LINING

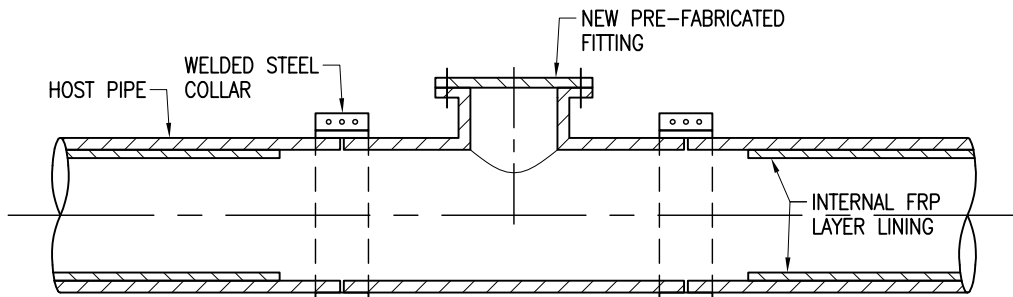

4 APPLY EPOXY BETWEEN CUT ENDS OF HOST PIPE AND EXISTING INTERNAL FRP LAYER LINING AND INSTALL SEALING SYSTEM

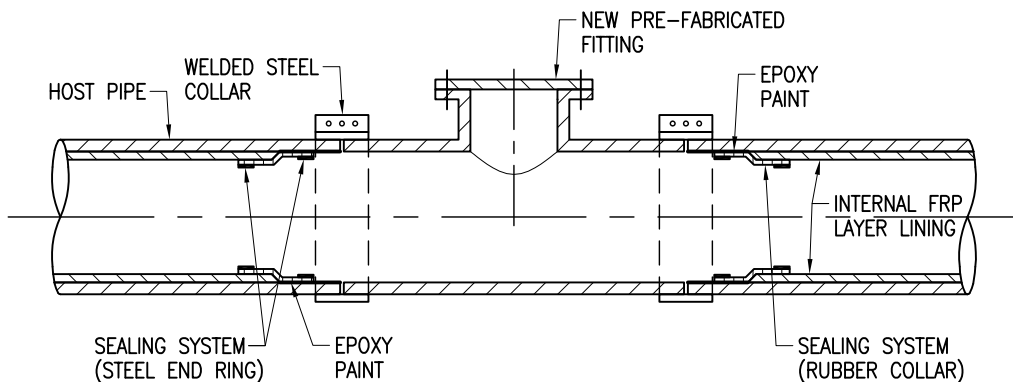

PROCEDURE FOR INSTALLATION OF PRE-FABRICATED FITTING ON PIPE REHABILITATED BY EXTERNAL FIBRE REINFORCED POLYMER (FRP) LAYER WRAP

1 REMOVE EXTERNAL FRP LAYER FOR INSTALLATION OF NEW FITTING

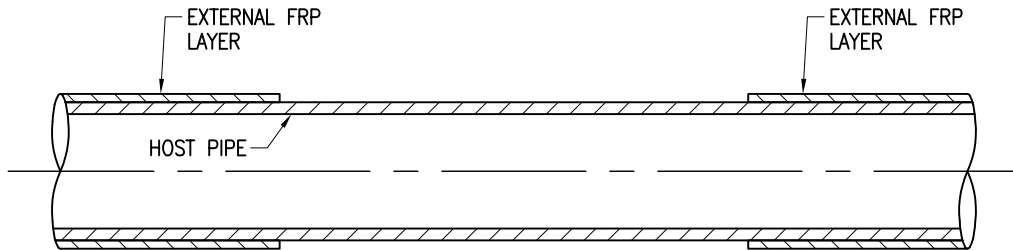

2 CUT EXISTING HOST PIPE AND INSTALL NEW FITTING

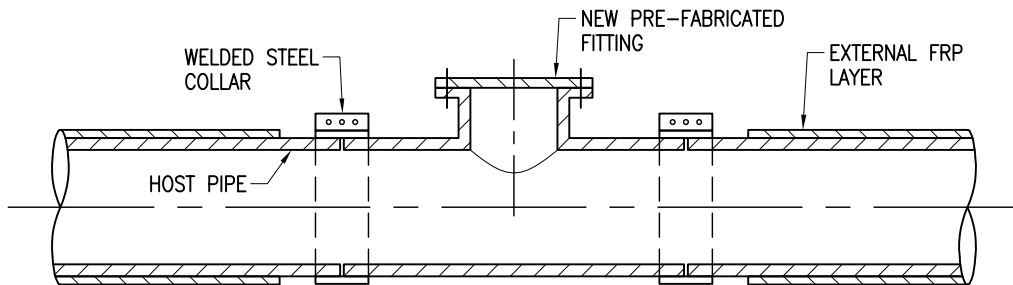

3 APPLY EPOXY BETWEEN WELDED STEEL COLLAR AND EXISTING EXTERNAL FRP LAYER

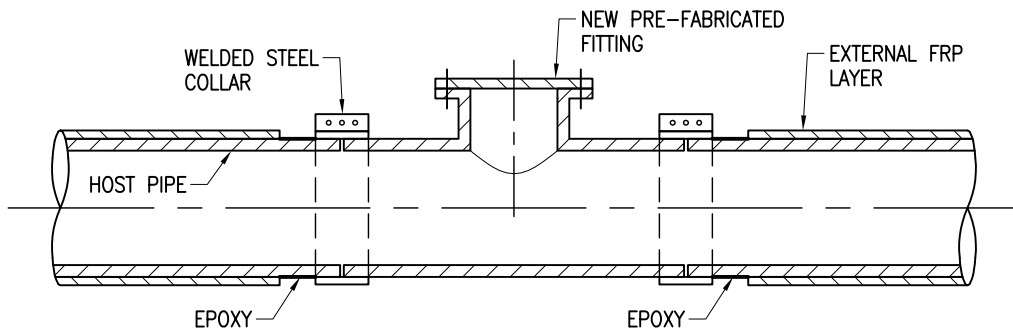

4 INSTALL SEALING SYSTEM

