











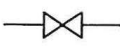

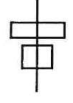

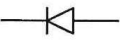

LIST OF SYMBOLS (1 OF 2)

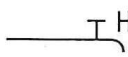
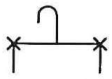
	ANGLE VALVE
	LOOSE JUMPER TYPE STOPCOCK
	GATE VALVE
	STORAGE CISTERN
	FLOAT SWITCH
	BALL FLOAT VALVE / FLOAT OPERATED VALVE
	NON-RETURN VALVE / CHECK VALVE
	DOUBLE NON-RETURN VALVE / CHECK VALVE
	WATER METER
	DRAW OFF POINTS - COLD WATER
	DRAW OFF POINTS - HOT WATER
	DRAW OFF POINT - COLD & HOT WATER
	DRAW OFF POINT - COLD & HOT WATER (SHOWER TYPE)
	WASHOUT PIPE
	OVERFLOW PIPE
	PUMP SET
	CALORIFIER
	BOILER
	STRAINER

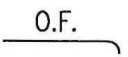
LIST OF SYMBOLS (2 OF 2)

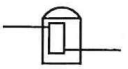

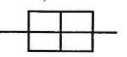
BASIN



FLUSHING CISTERN & WATER CLOSET

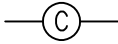

CHECK METER POSITION (FOR CHECKING AND WASTE DETECTION PURPOSES)



INSTANTANEOUS GAS WATER HEATER



PRESSURE REDUCING VALVE (SMALL END DENOTES LOW PRESSURE)



PRESSURE RELIEF VALVE / SAFETY VALVE



TEMPERATURE RELIEF VALVE



COMBINED TEMPERATURE AND PRESSURE RELIEF VALVE



ANTI-VACUUM VALVE



EXPANSION VESSEL



BUTTERFLY VALVE

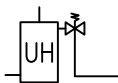

UNVENTED ELECTRIC THERMAL STORAGE WATER HEATER



PRESSURE TYPE THERMAL STORAGE WATER HEATER

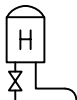

NON-PRESSURE TYPE HEATER



BACKFLOW PREVENTER

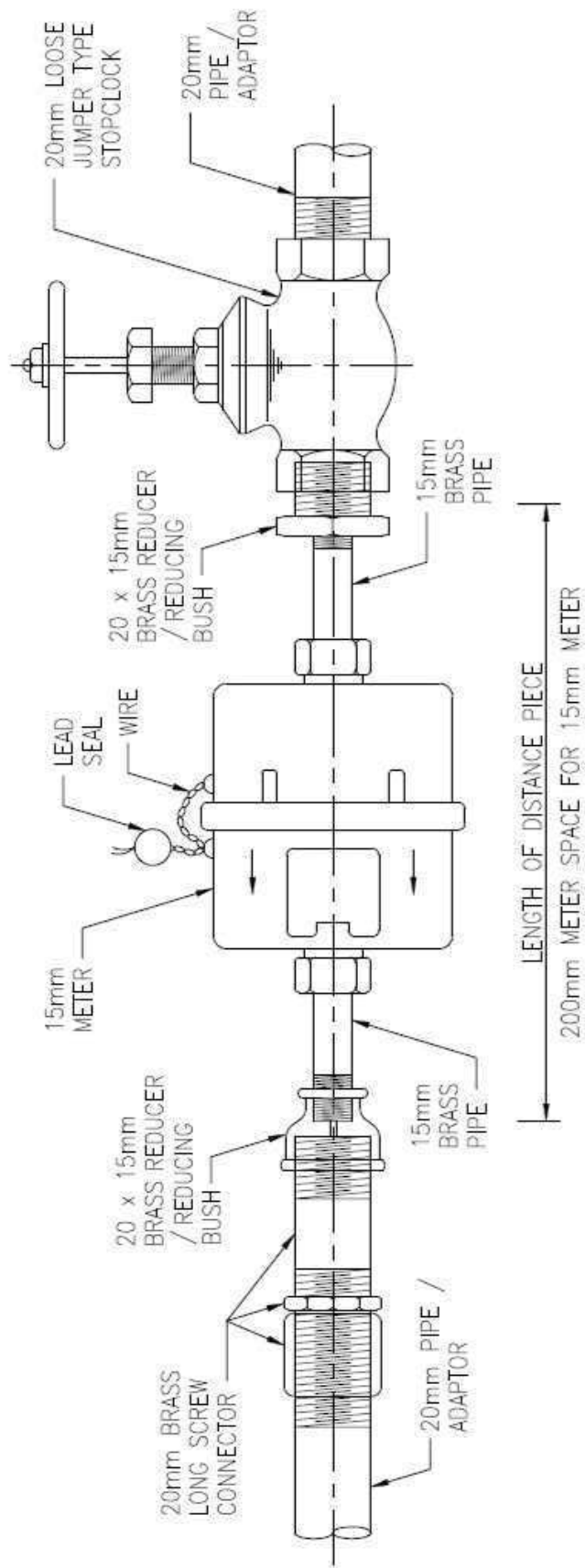

NOTES:

1. ALL THREADING TO BS 21.
2. METER POSITION TO BE USED FOR LINED G.I., COPPER AND THERMOPLASTIC INSIDE SERVICE.

TYPICAL INSTALLATION OF A 15mm DIAMETER WATER METER

FIG. 3

METER SIZE (mm)		15	25	40
<u>DIMENSION (mm)</u> A	NON-AMR METERS	200	311	#346/ *421
	AMR METERS	200	370	421

Remark: (#) For meter planned to be installed before 1 September 2022.
 (*) For meter planned to be installed on or after 1 September 2022.

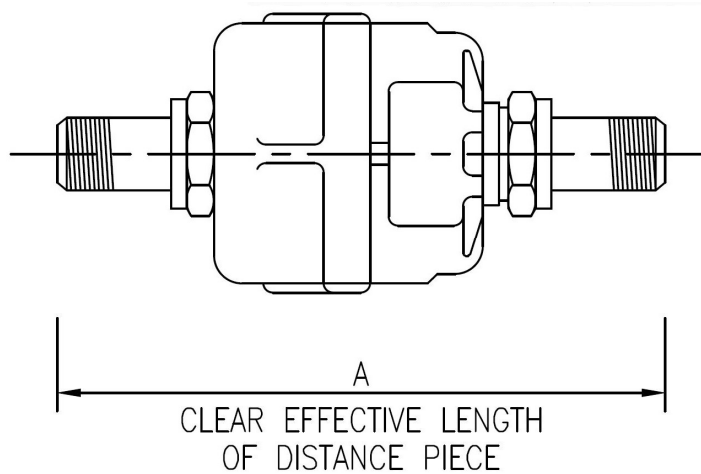

METER SIZE (mm)	50	80	100	150	200	250	300
<u>DIMENSION (mm)</u> A	310	413	483	500	520	450	500

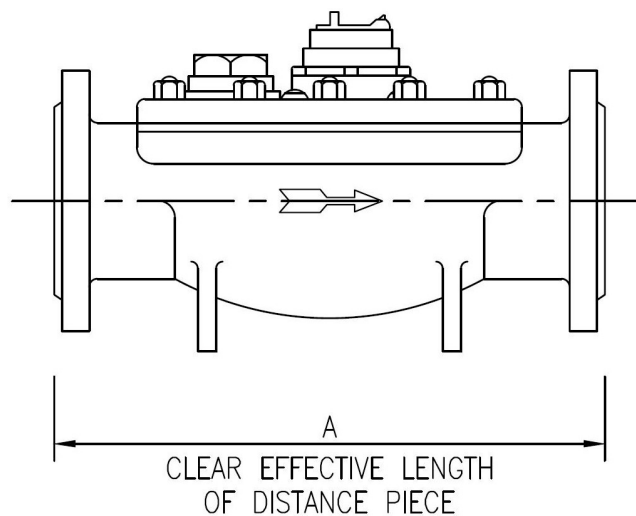

METER DIMENSIONS

Fig. 4

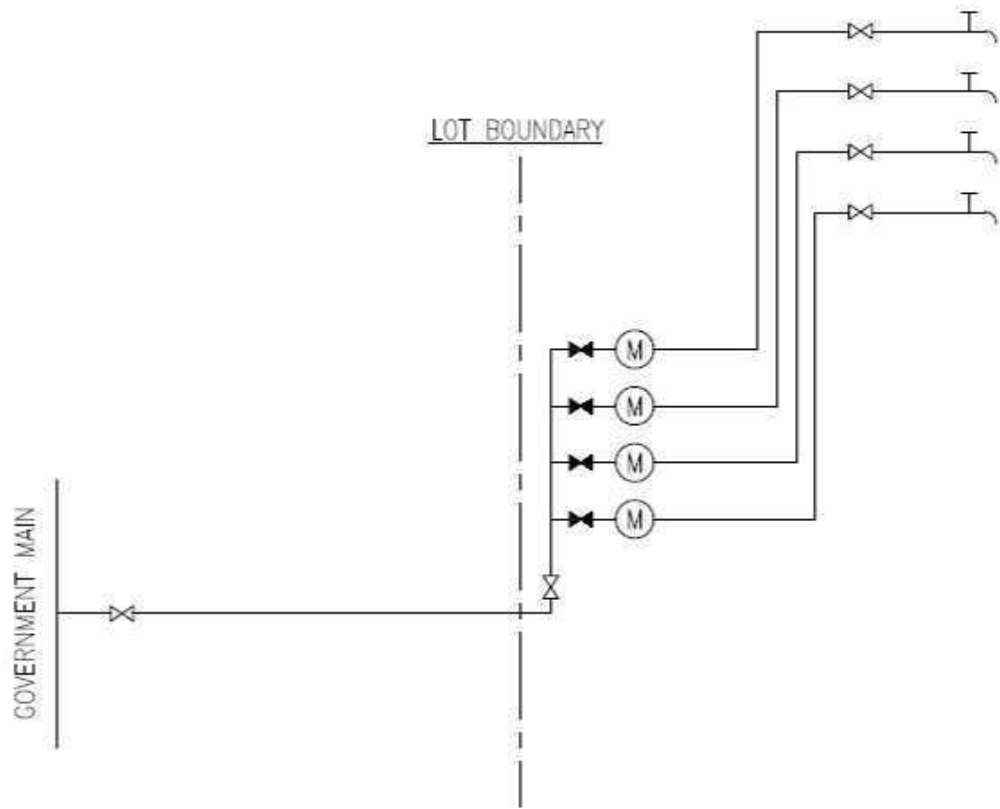

DIRECT SUPPLY (WITHOUT STORAGE TANK)

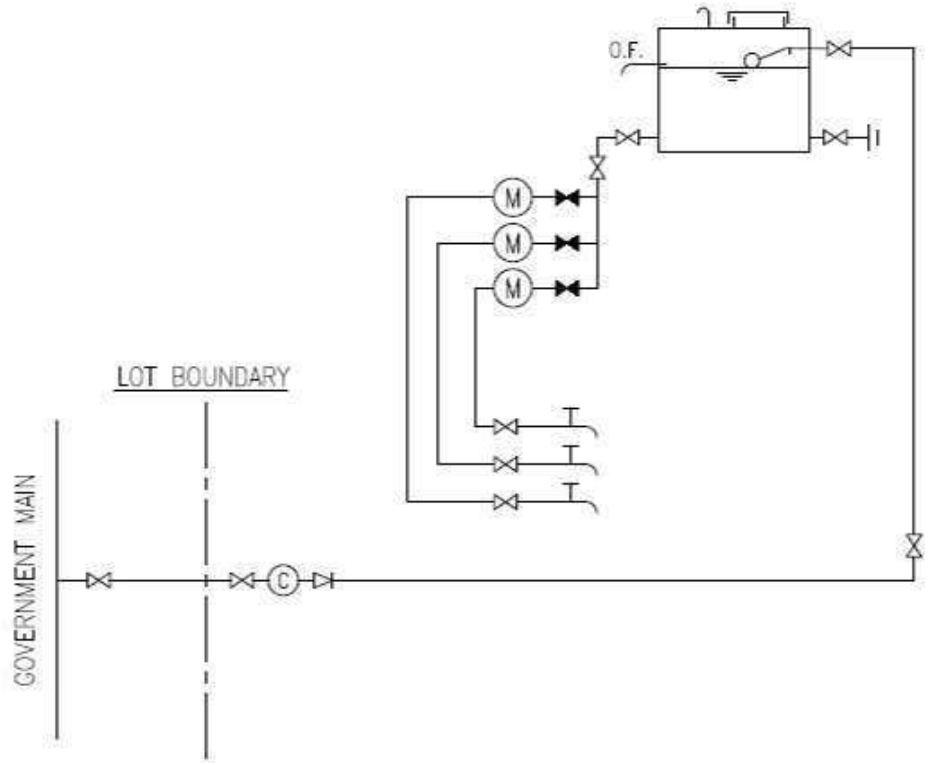

INDIRECT SUPPLY SYSTEM (THROUGH STORAGE TANK)

NOTES:

1. IN CASE THE METERS ARE SITED AT ROOF LEVEL AND THE SYSTEM PRESSURE IS LESS THAN 15M, FULLWAY GATE VALVES INSTEAD OF LOOSE JUMPER STOPCOCKS SHALL BE FITTED BEFORE METER POSITIONS.

FIG. 5

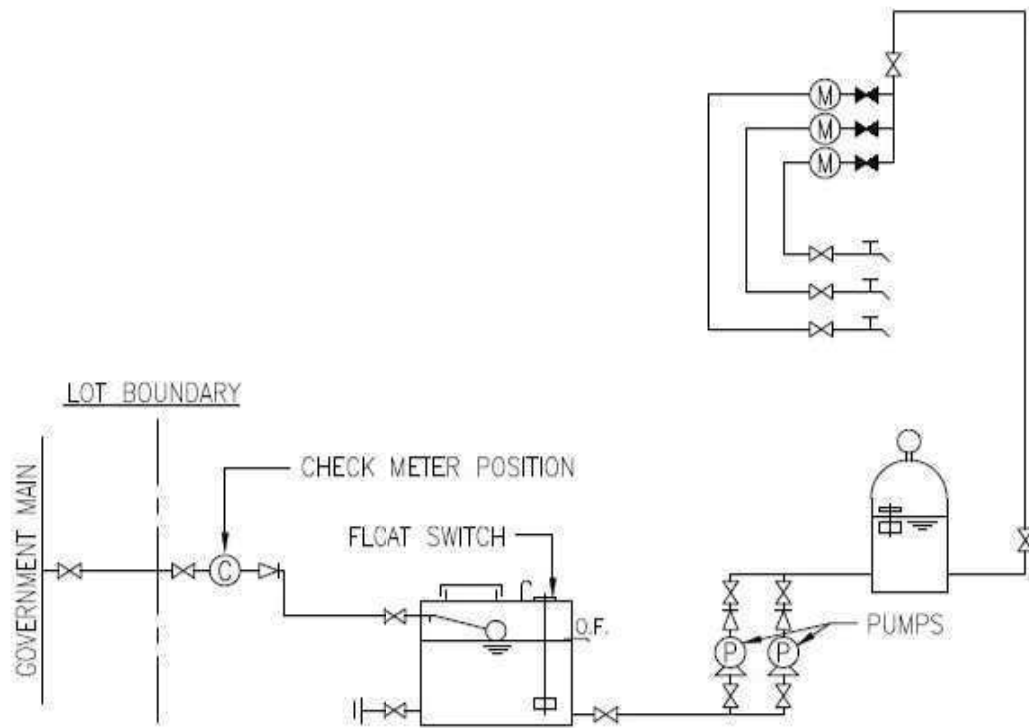

HYDRO PNEUMATIC PUMP SYSTEM

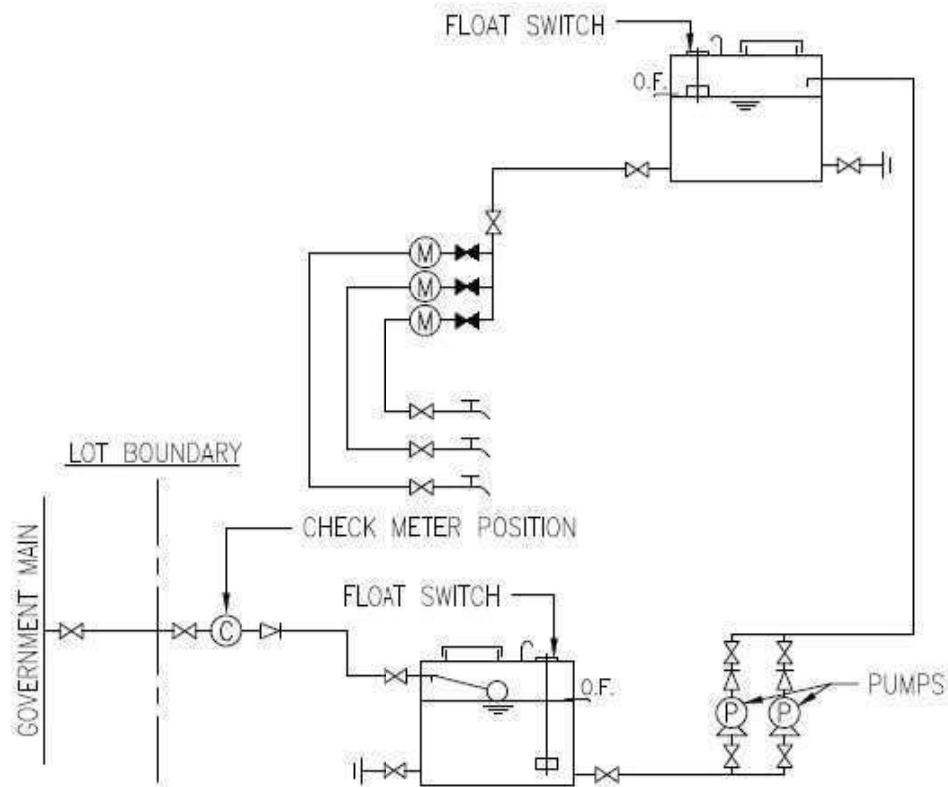

SUMP AND PUMP SYSTEM

INDIRECT SUPPLY SYSTEM

NOTES:

1. IN CASE THE METERS ARE SITED AT ROOF LEVEL AND THE SYSTEM PRESSURE IS LESS THAN 15M, FULLWAY GATE VALVES INSTEAD OF LOOSE JUMPER STOPCOCKS SHALL BE FITTED BEFORE METER POSITIONS.

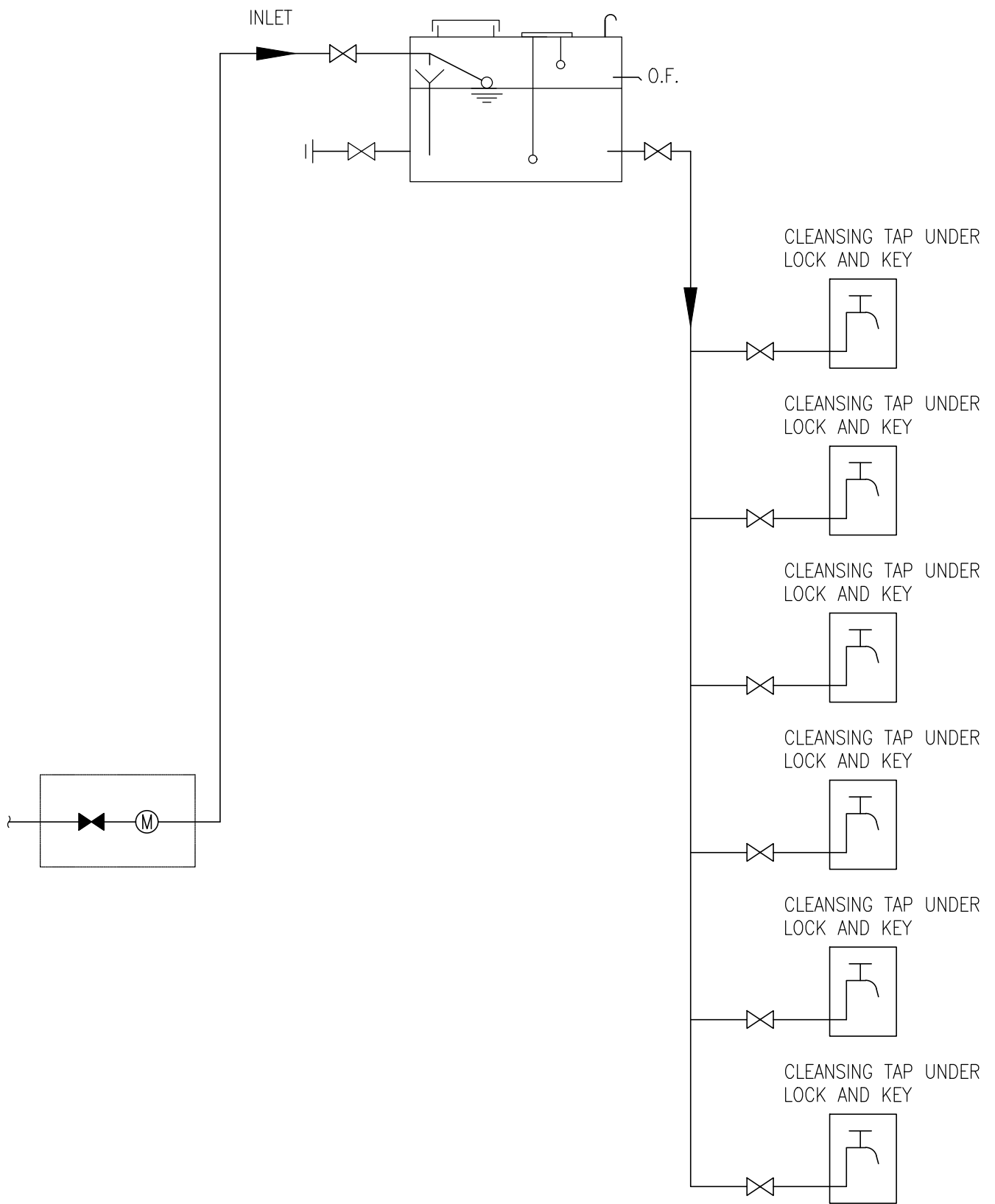

SCHEMATIC DIAGRAM FOR CLEANSING (TYPE I)

FIG. 6A

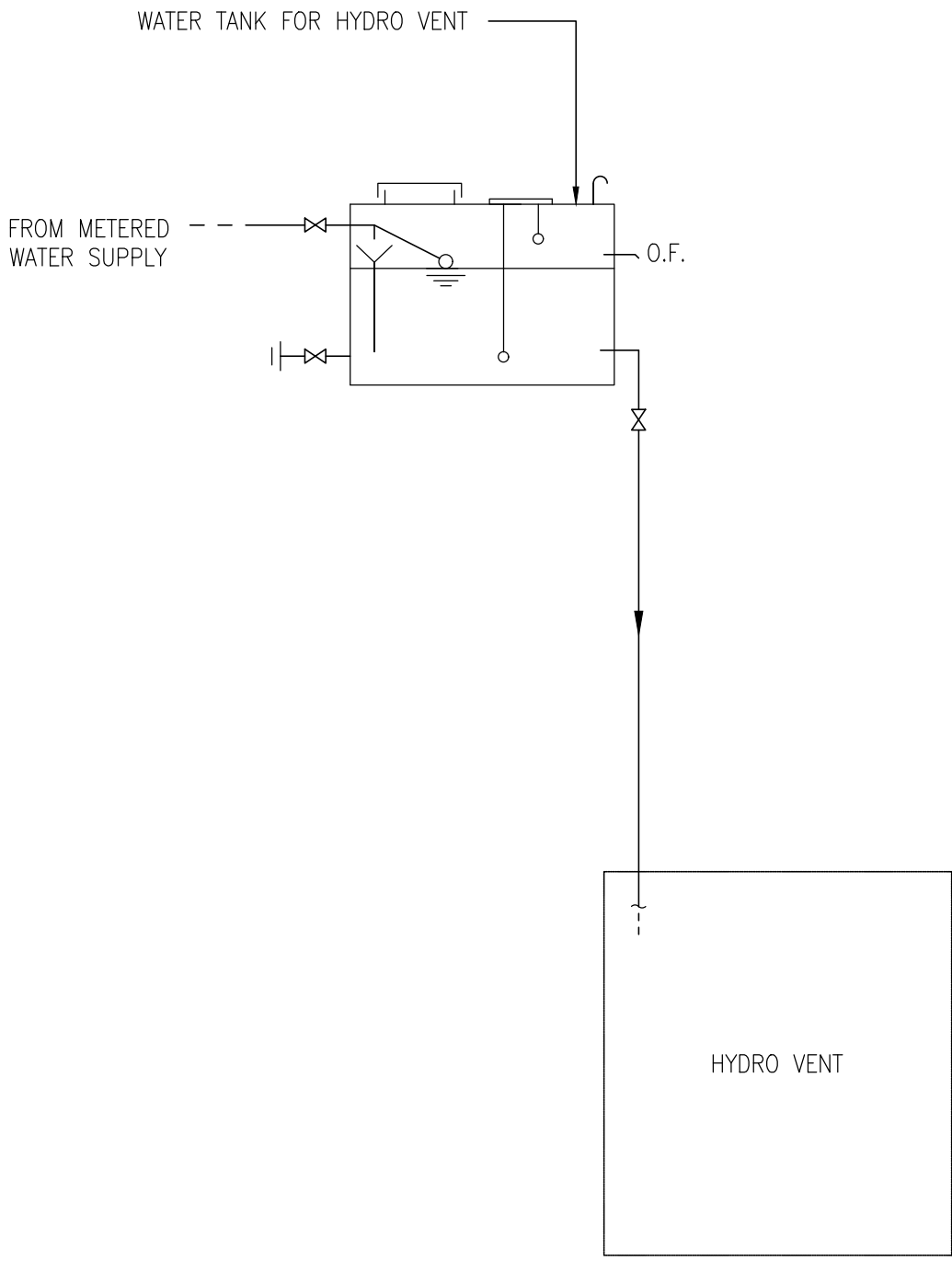

SCHEMATIC LAYOUT OF HYDRO-VENT
RE-CIRCULATION SYSTEM
(SHEET 1 OF 2)

FIG. 6C

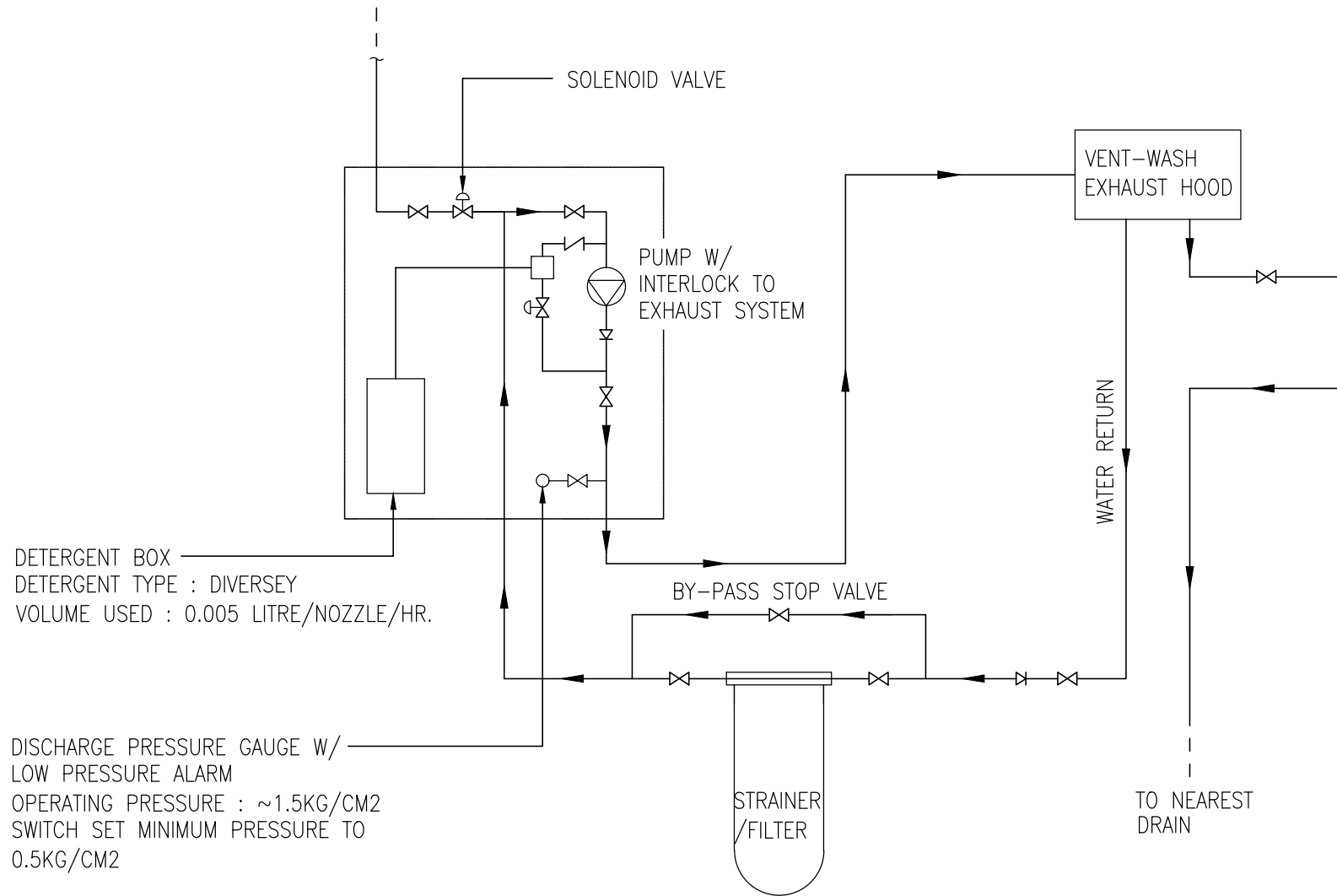

SCHEMATIC LAYOUT OF HYDRO-VENT

RE-CIRCULATION SYSTEM

(SHEET 2 OF 2)

REFERENCE ONLY AND THE DETAIL ARRANGEMENT
SHALL BE SUBJECTED TO INDIVIDUAL DESIGN

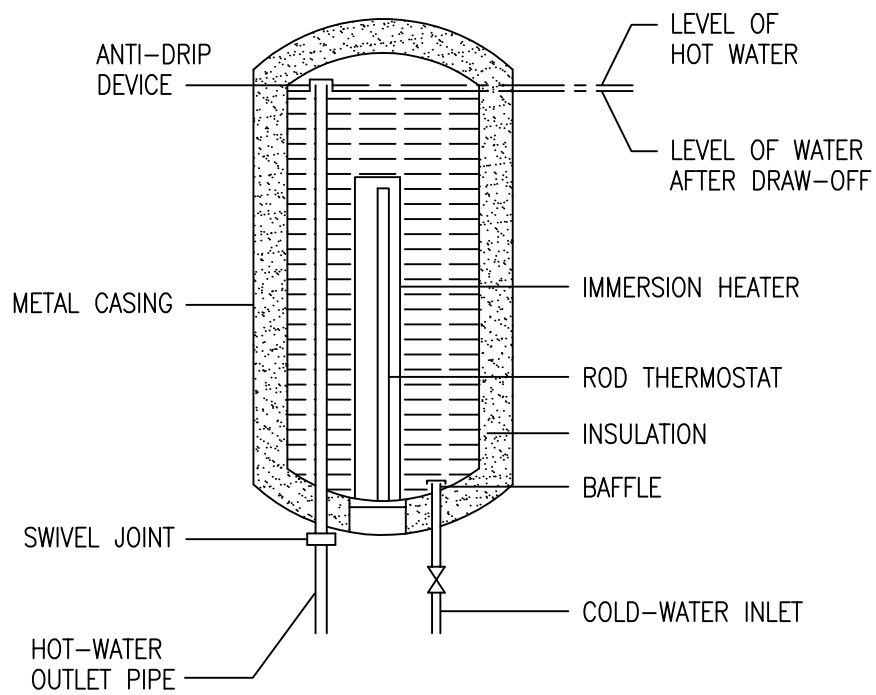

ESSENTIAL COMPONENTS OF A NON-PRESSURE TYPE HEATER

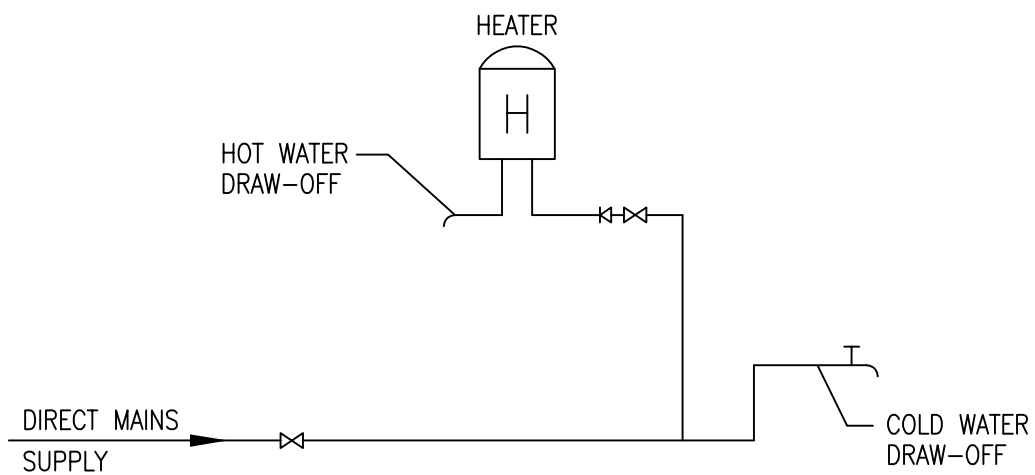

LAYOUT OF A NON-PRESSURE TYPE DISPENSER

NON-PRESSURE TYPE HEATER / DISPENSER (SHEET 1 OF 2)

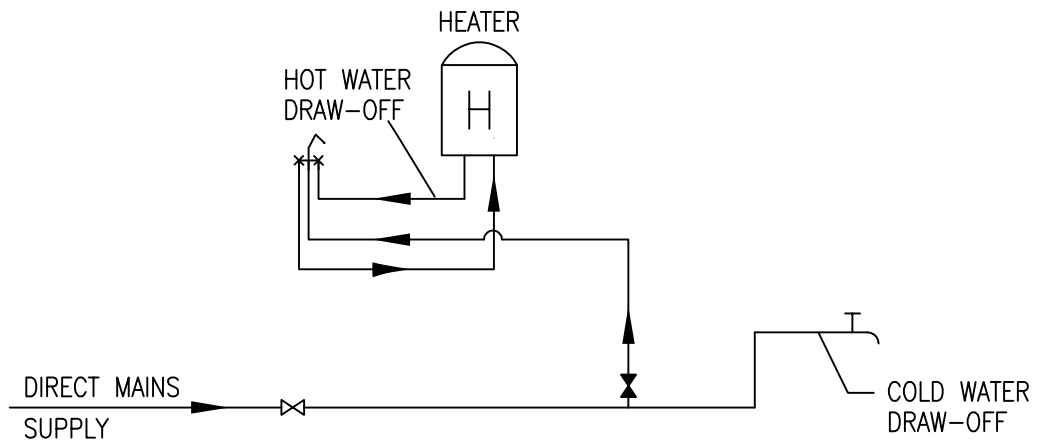

LAYOUT OF A NON-PRESSURE TYPE HEATER
WITH LOOSE JUMPER TYPE STOPCOOK

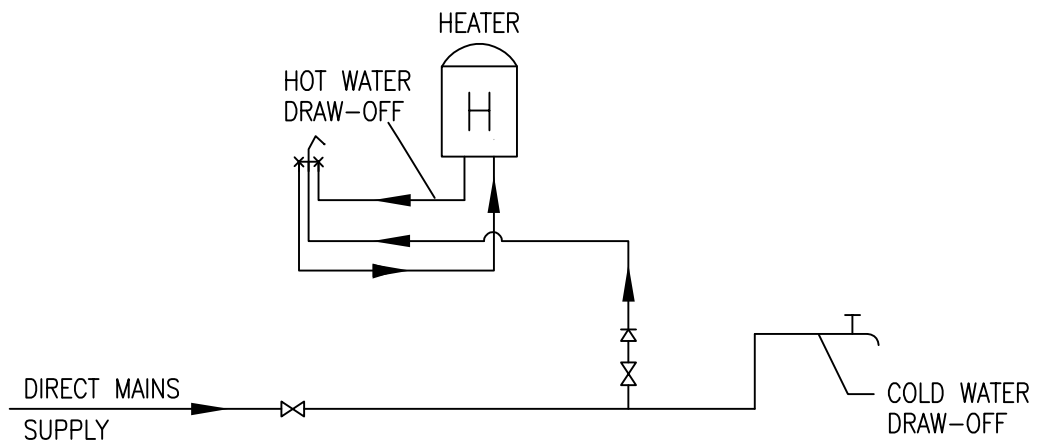

LAYOUT OF A NON-PRESSURE TYPE HEATER
WITH GATE VALVE AND NON-RETURN VALVE

NON-PRESSURE TYPE HEATER / DISPENSER (SHEET 2 OF 2)

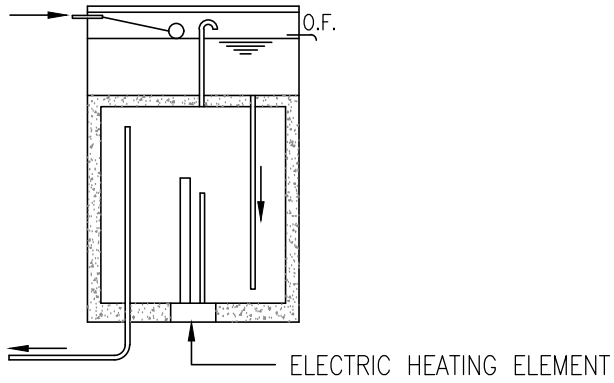

SECTION THROUGH A CISTERN TYPE WATER HEATER / DISPENSER

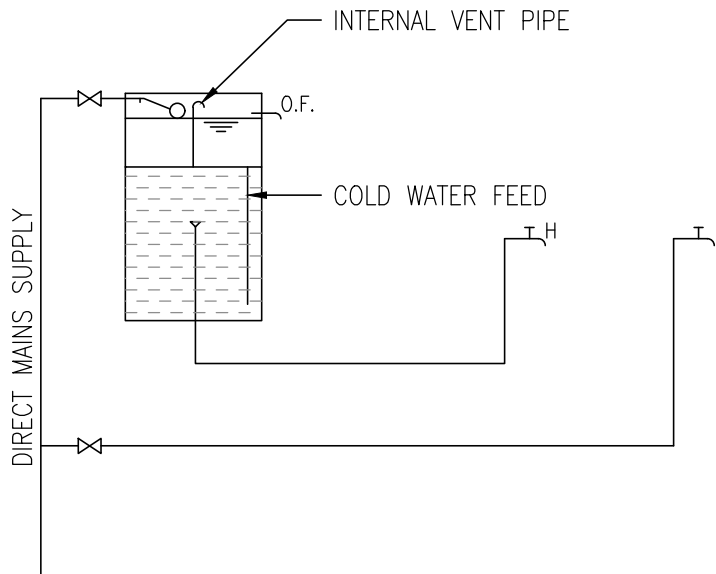

LAYOUT OF A CISTERN TYPE WATER HEATER / DISPENSER

CISTERN TYPE WATER HEATER

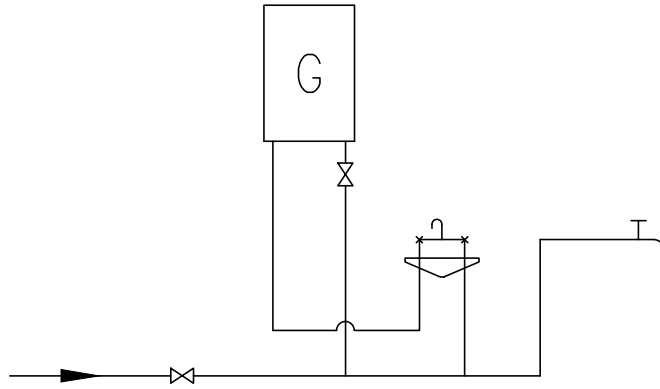

INSTANTANEOUS GAS WATER HEATER
CONNECTED DIRECTLY TO MAINS SUPPLY

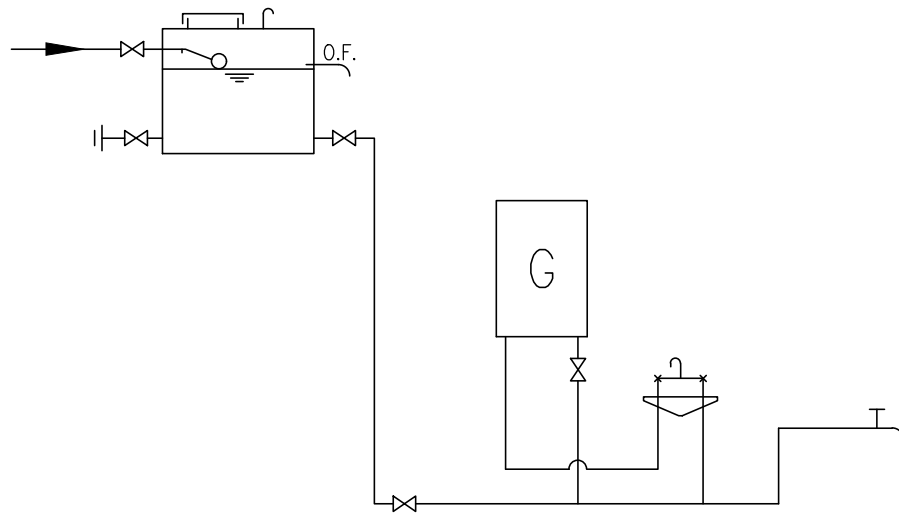

INSTANTANEOUS GAS WATER HEATER
CONNECTED INDIRECTLY TO MAINS SUPPLY

INSTANTANEOUS GAS WATER HEATER

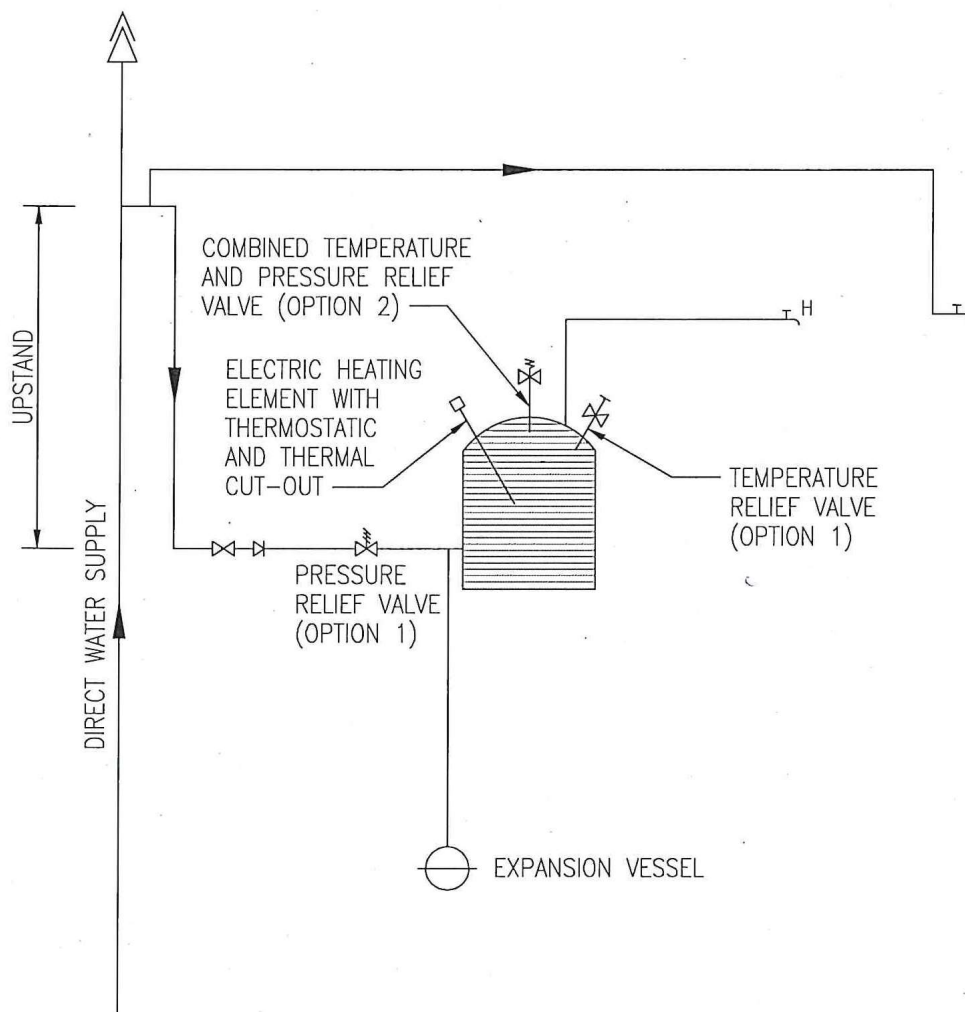

NOTES :

1. THE FACTORY TEST PRESSURE OF THE HEATER SHALL BE IN EXCESS OF 1.5 TIMES THE MAXIMUM STATIC PRESSURE AT THE MAINS WATER SUPPLY POINT.
2. A COMBINED TEMPERATURE AND PRESSURE RELIEF VALVE (OPTION 2) MAY BE USED IN LIEU OF A TEMPERATURE RELIEF VALVE AND A PRESSURE RELIEF VALVE (OPTION 1).
3. THE SAFETY DEVICES ARE UNDER THE CONTROL OF THE ELECTRICAL PRODUCTS (SAFETY) REGULATION ADMINISTERED BY THE ELECTRICAL AND MECHANICAL SERVICES DEPARTMENT.
4. EXPANSION VESSEL IS ONLY REQUIRED WHEN A NON-RETURN VALVE OR A PRESSURE REDUCING VALVE OF THE NON-BACKFLOW TYPE IS FITTED IN THE COLD WATER INLET.

LAYOUT OF UNVENTED ELECTRIC THERMAL STORAGE TYPE WATER HEATER

FIG. 10

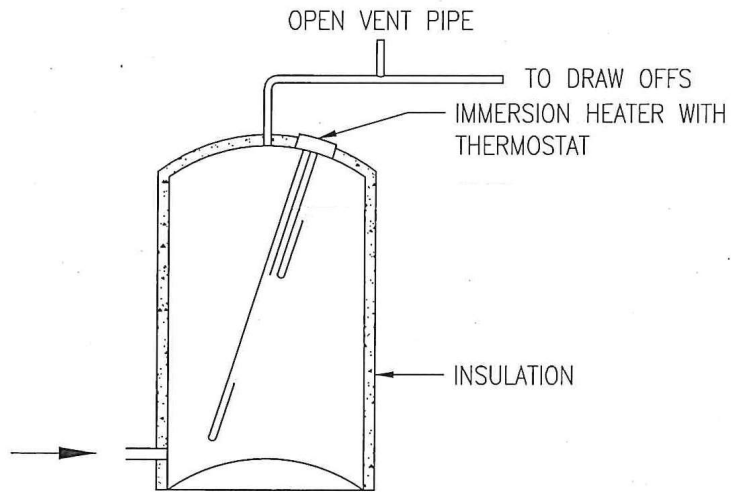

ESSENTIAL COMPONENTS OF A PRESSURE TYPE
THERMAL STORAGE WATER HEATER

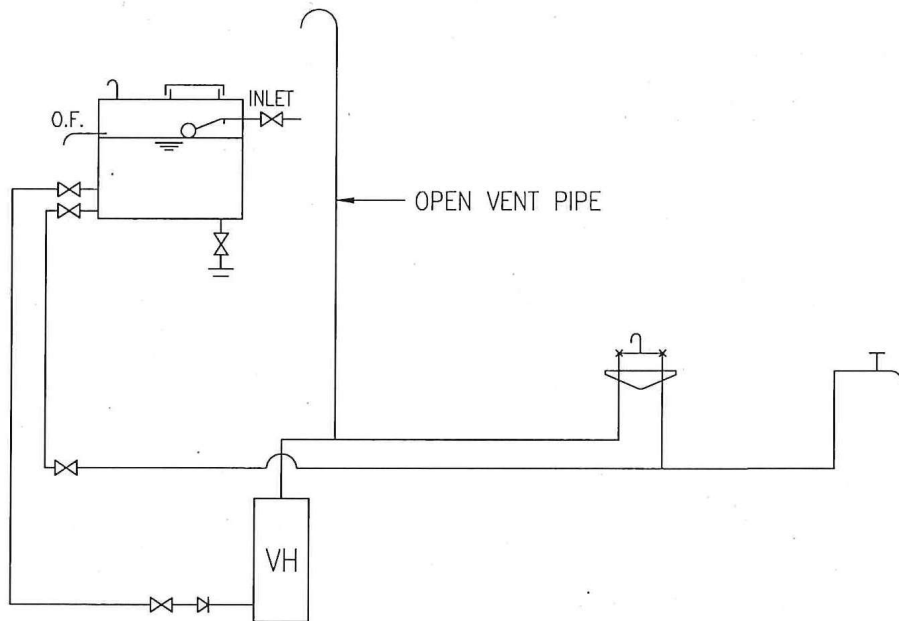

LAYOUT OF A PRESSURE TYPE THERMAL STORAGE WATER HEATER

NOTE: THIS TYPE OF HEATER SHALL BE SUPPLIED FROM A STORAGE CISTERN, EXCEPT IT IS INSTALLED IN FLATS SUPPLIED THROUGH THE INDIRECT OR SUMP AND PUMP SYSTEM.

PRESSURE TYPE THERMAL STORAGE WATER HEATER

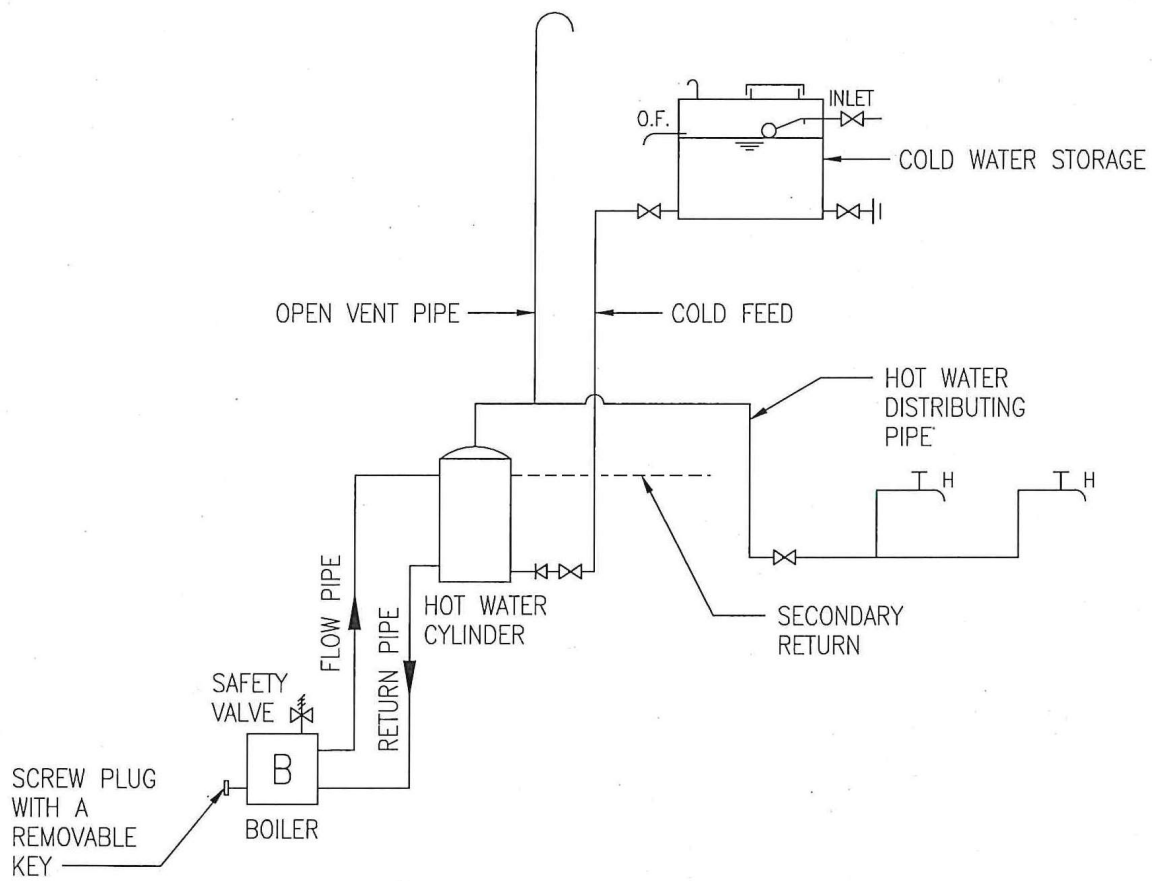

DIRECT CENTRALISED HOT WATER SYSTEM

FIG. 12

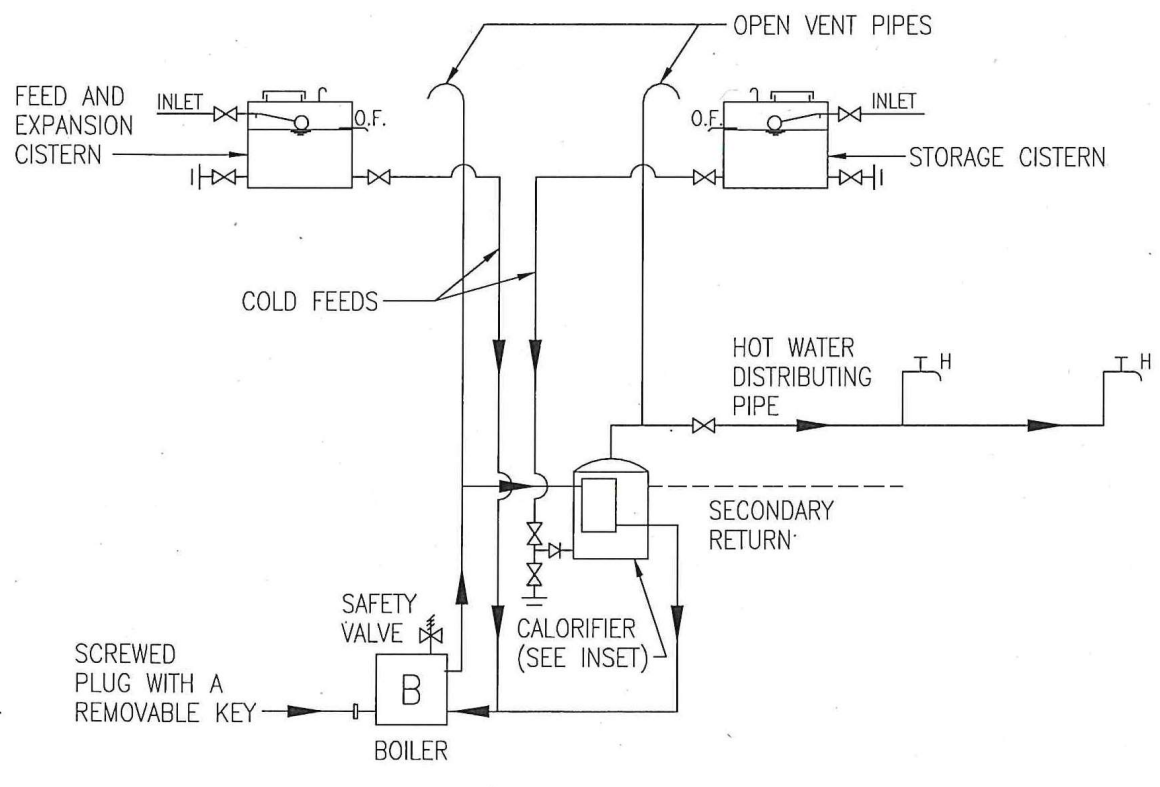
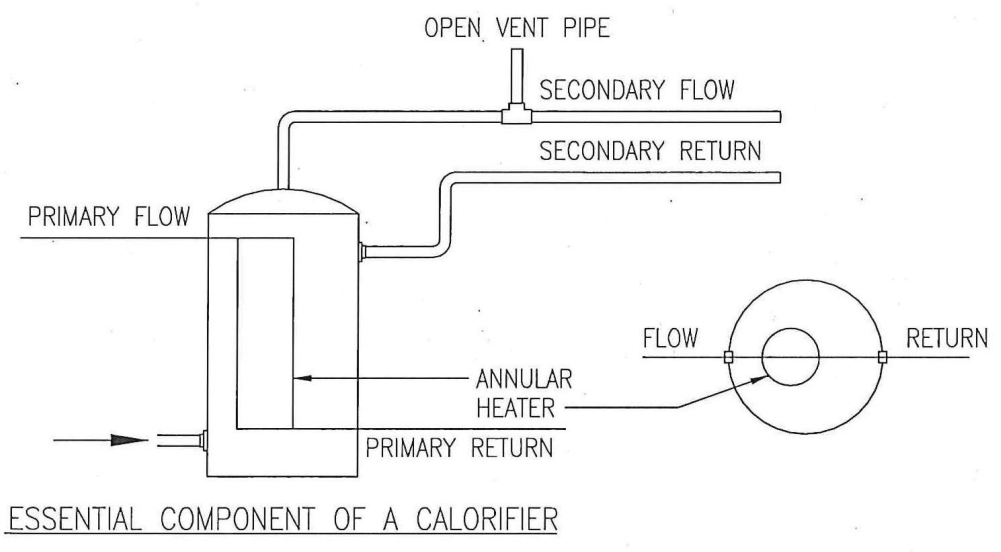
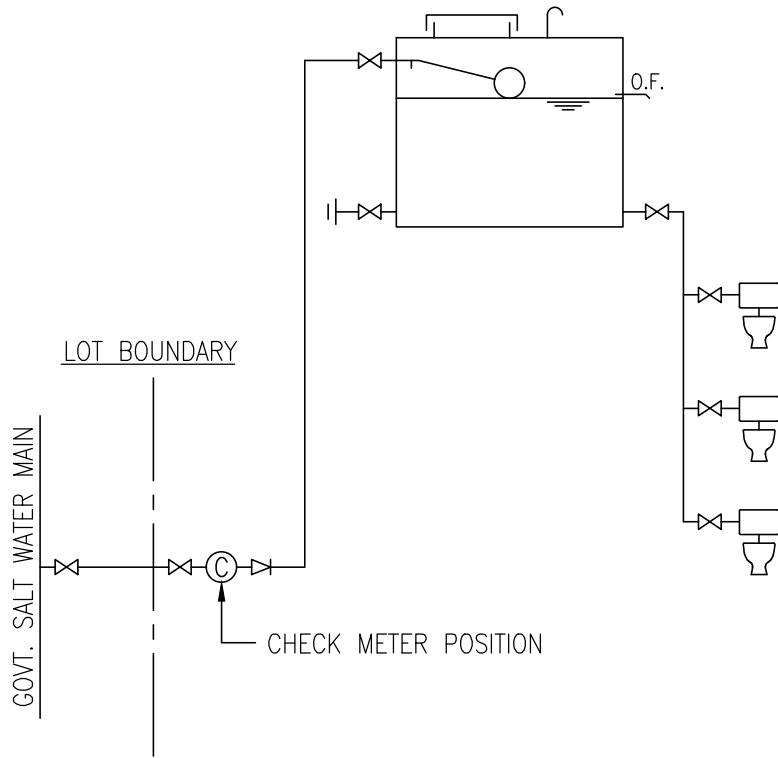
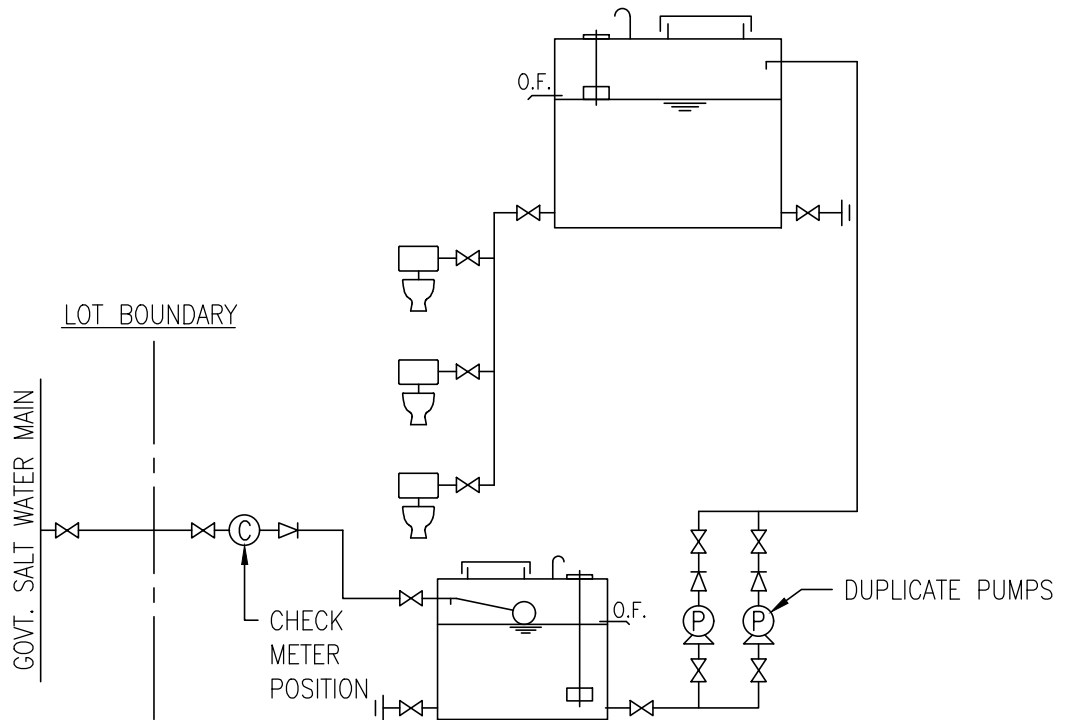

FIG. 13



INDIRECT SALT WATER FLUSHING SUPPLY SYSTEM
(WITH DIRECT SUPPLY TO ROOF STORAGE TANK)



INDIRECT SALT WATER FLUSHING SUPPLY SYSTEM
(WITH SUMP AND PUMP SYSTEM)

SALT WATER FLUSHING SUPPLY SYSTEM

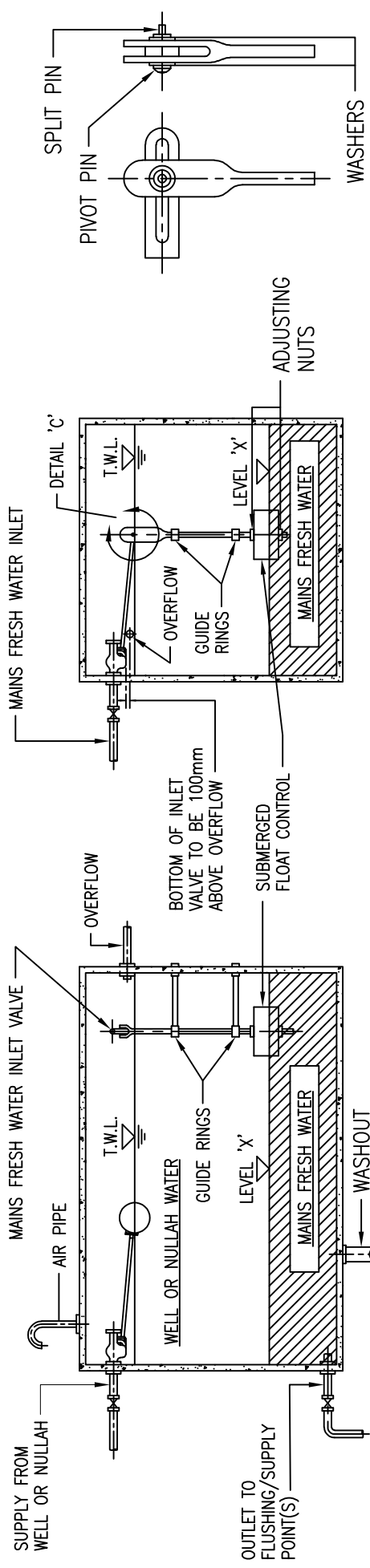

SECTION A-A

SECTION B-B

DETAIL 'c'

NOTES :

1. VOLUME BELOW LEVEL 'X' FOR MAINS FRESH WATER STORAGE SHALL BE APPROVED BY WATER AUTHORITY.
2. OVERFLOW SHALL BE TWICE THE DIAMETER OF LARGEST INLET OR OF 40mm DIAMETER WHICHEVER BE THE GREATER.
3. MATERIALS USED SHALL BE CAPABLE OF WITHSTANDING THE CORROSIVE ACTION OF SALT WATER.
4. THIS DRAWING IS EXTRACTED FROM W1543/5B.

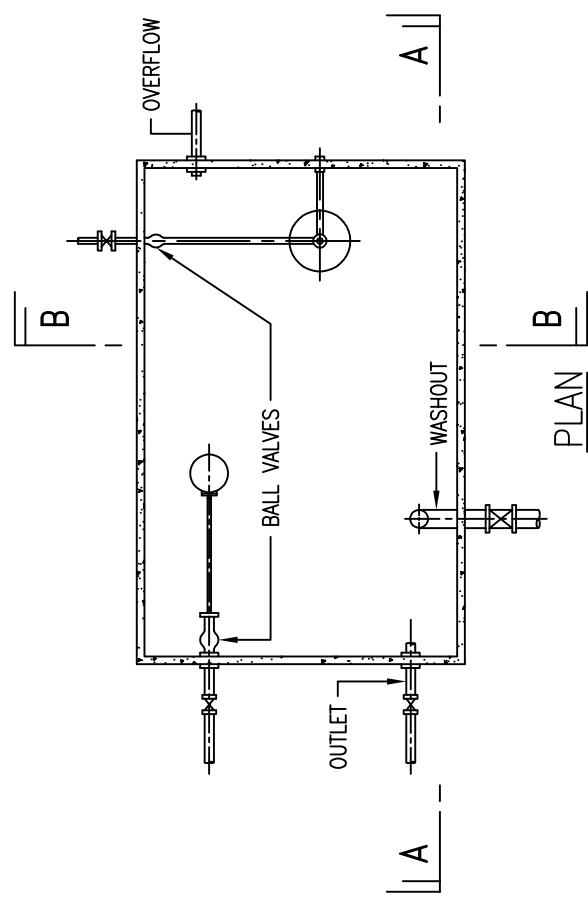

PLAN

FLUSHING SUPPLY STORAGE CISTERNS - MIXED SUPPLY

(NOT TO SCALE)

FIG. 15

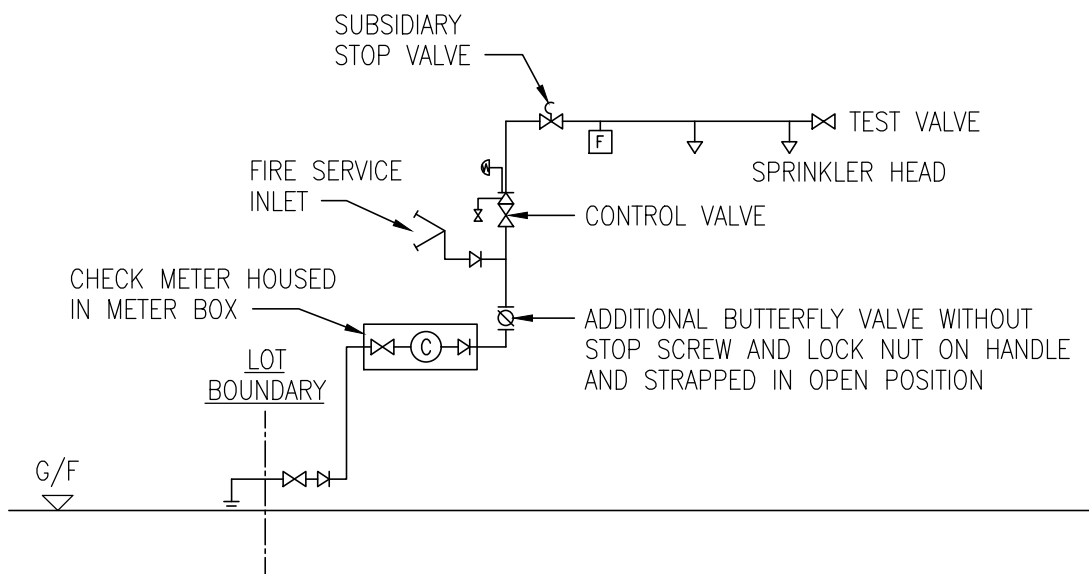

LAYOUT DRAWING FOR IMPROVISED SPRINKLER SYSTEM

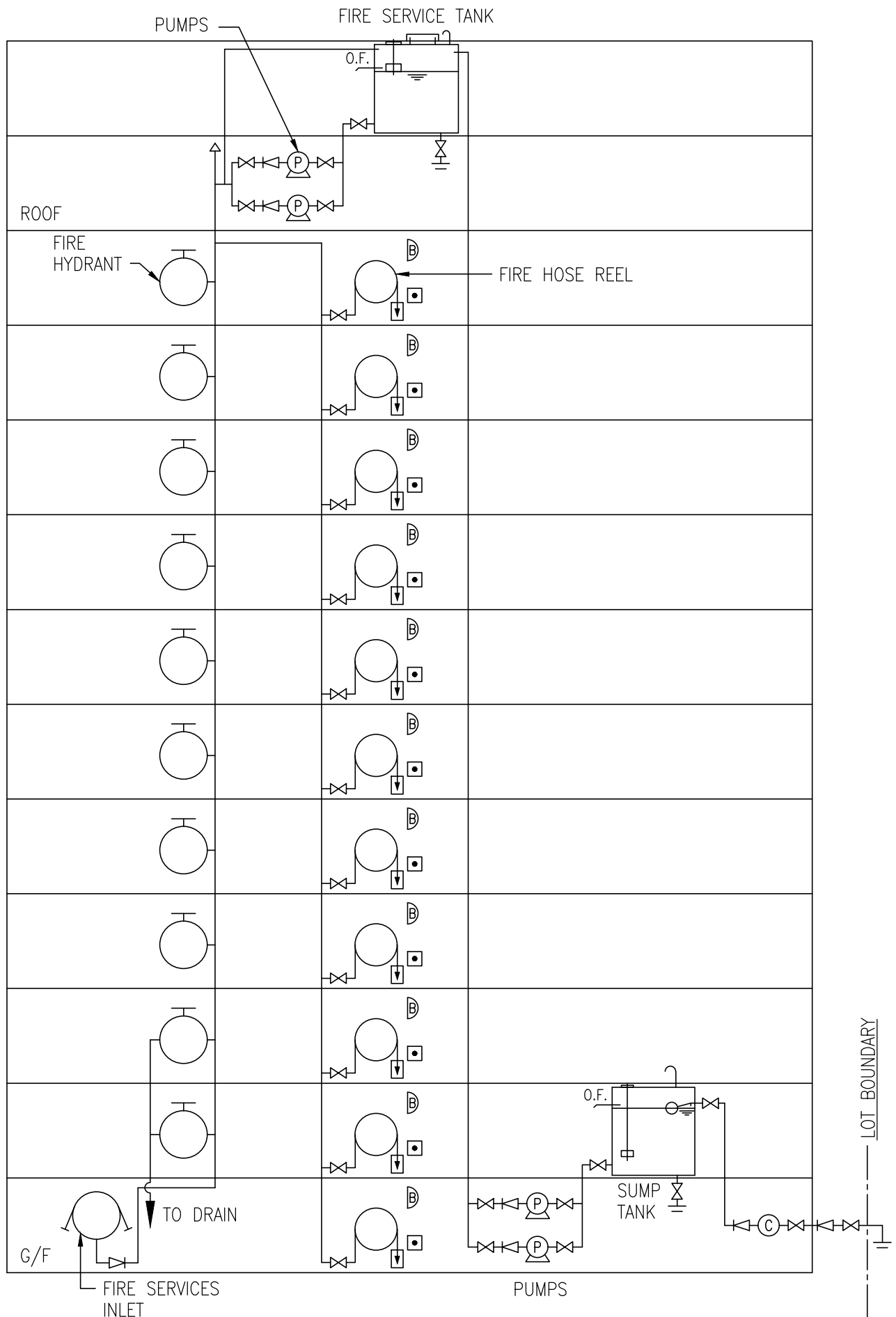

LAYOUT DRAWING FOR FIRE HYDRANT/HOSE REEL SYSTEM

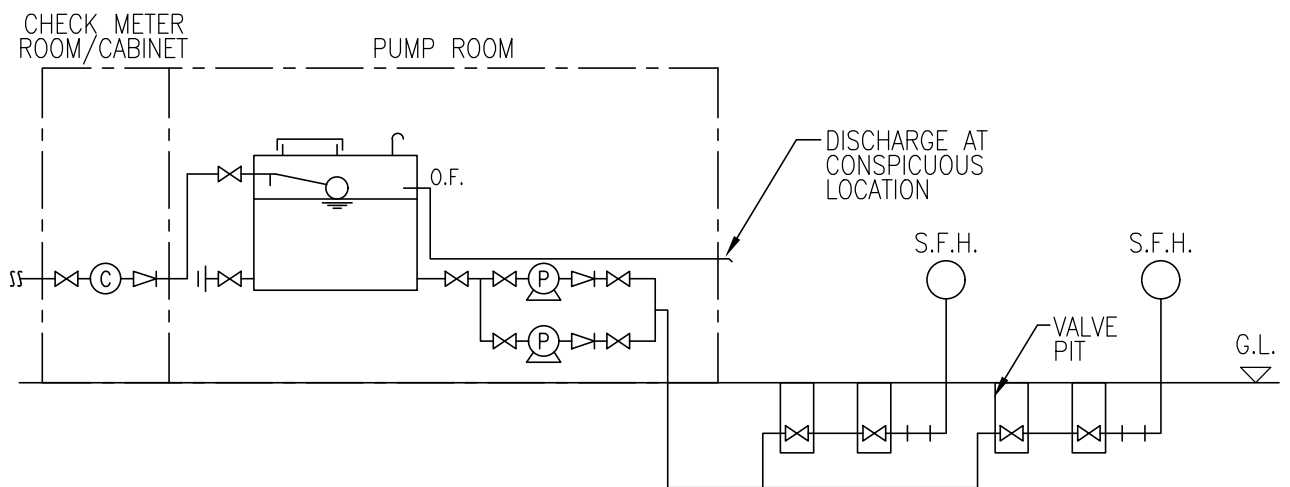

ABBREVIATION :

S.F.H. STREET FIRE HYDRANT

LAYOUT DRAWING FOR STREET FIRE HYDRANT SYSTEM

FIG. 21

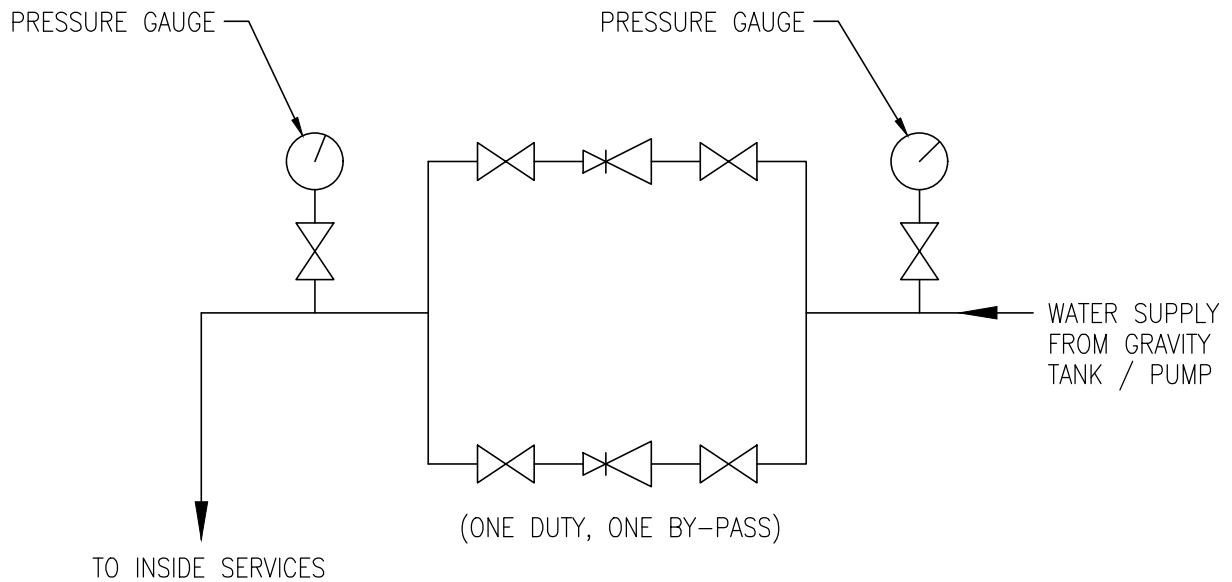

NOTES :

1. A BYPASS ARRANGEMENT WITH THE PROVISION OF A SECOND PRESSURE REDUCING VALVE TO ENABLE ISOLATION OF ANY DEFECTIVE PRESSURE REDUCING VALVE FOR REPAIR AND REPLACEMENT IS USED.
2. THE PRESSURE REDUCING VALVES FOR USE WITH FRESH WATER SHOULD BE MANUFACTURED FROM MATERIALS SUITABLE FOR USE IN CONTACT WITH POTABLE WATER.
3. THE PRESSURE REDUCING VALVES FOR USE WITH SALT WATER SHOULD BE MANUFACTURED FROM MATERIALS CAPABLE OF WITHSTANDING THE CORROSIVE EFFECT OF SALT WATER.

SCHEMATIC LAYOUT OF PRESSURE REDUCING VALVES

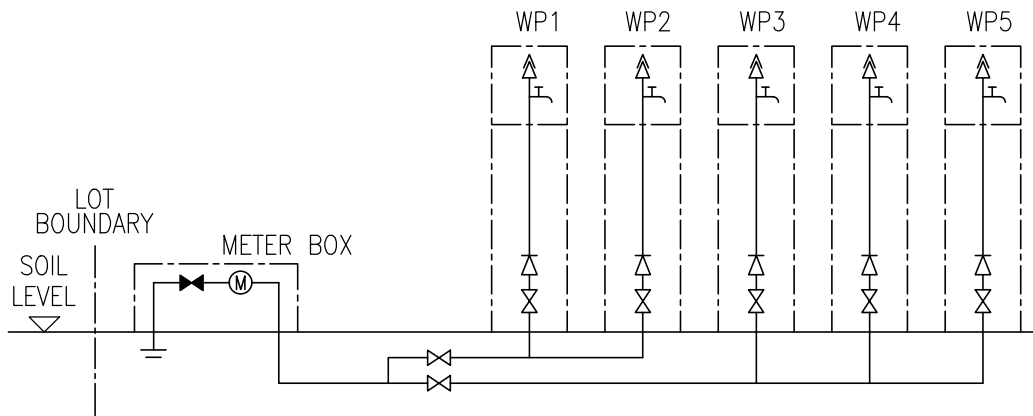

ABBREVIATION :
 WP WATER POINT

WATERING FLOWER BEDS PLUMBING SYSTEM

FIG. 23

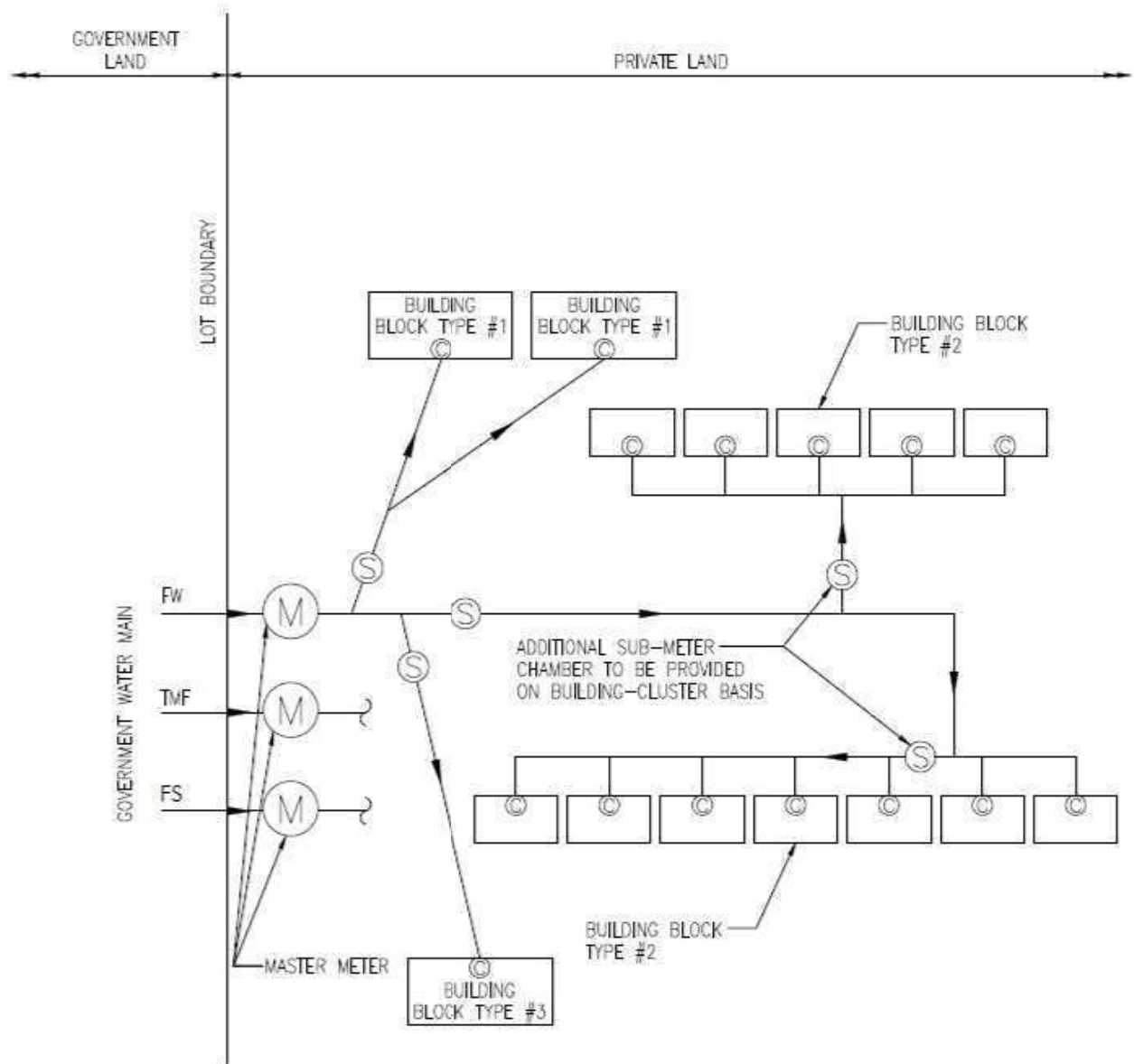

TYPICAL CONFIGURATION OF MASTER METER AND SUB-METER CHAMBERS
IN MULTIPLE-BLOCK DEVELOPMENT

NOTES :

1. SUB-METER CHAMBERS FOR FIRE SERVICE NOT SHOWN FOR CLARITY.
2. SUB-METER CHAMBERS NOT REQUIRED FOR TMF

LEGEND :

- (M) MASTER METER
- (S) CHECK METER POSITION IN SUB-METER CHAMBER / BOX / CABINET
- (C) CHECK METER POSITION IN BUILDING BLOCK

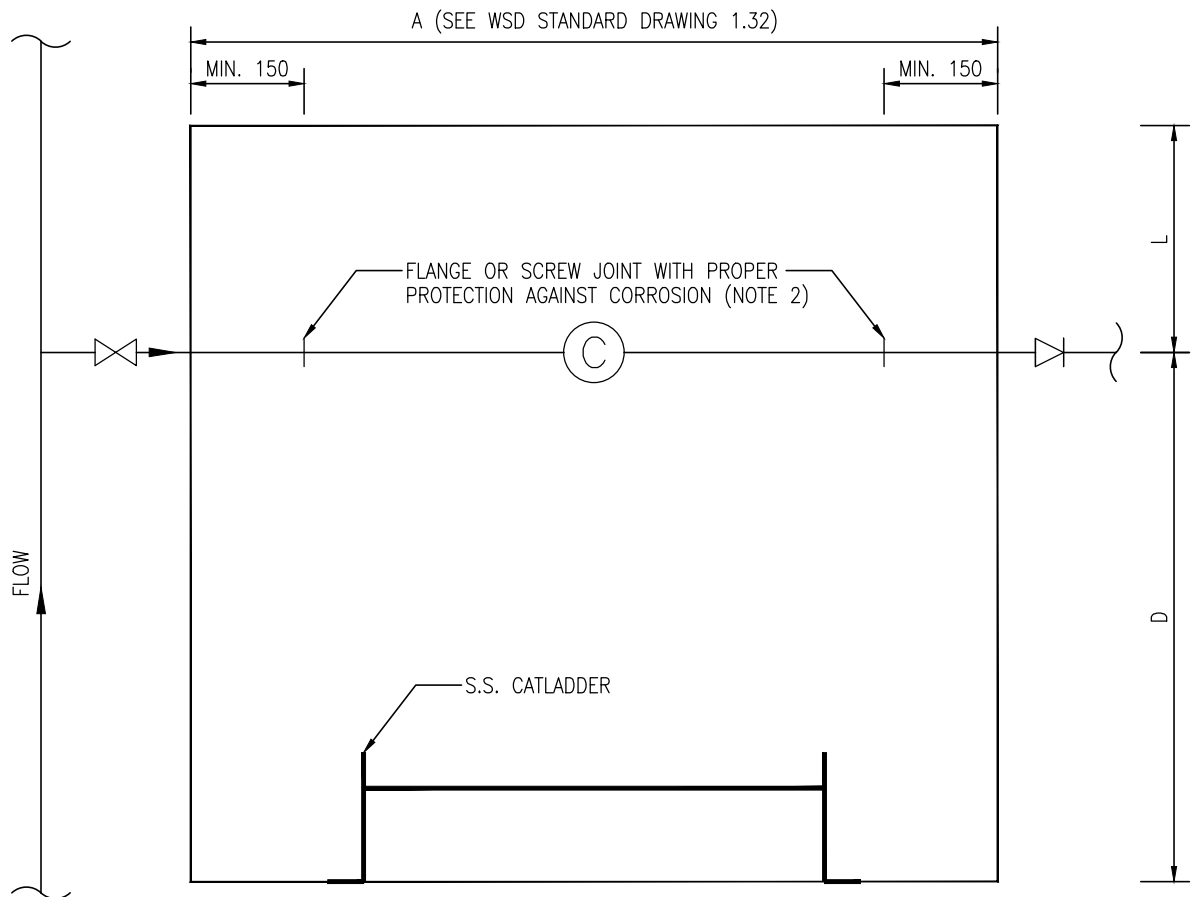

PLAN OF TYPICAL SUB-METER CHAMBER

MAX PIPE DIAMETER (mm)	MIN. WORKING CLEARANCE L (mm)	MIN. DISTANCE BETWEEN CENTRELINE OF PIPE AND INTERNAL WALL FACE D (mm)
50	310	700
80	380	
≥100	400	

NOTES :

1. DETAILS OF THE CHAMBER SIMILAR TO WASTE DETECTION CHAMBER AND SHALL BE REFERRED TO WSD STANDARD DRAWING 1.32.
2. PROTECTION TO FLANGE JOINT / COUPLING / ADAPTOR SHALL BE PROVIDED USING PETROLEUM ANTICORROSION TAPES WITH PRIMER AND MASTIC FILLER.

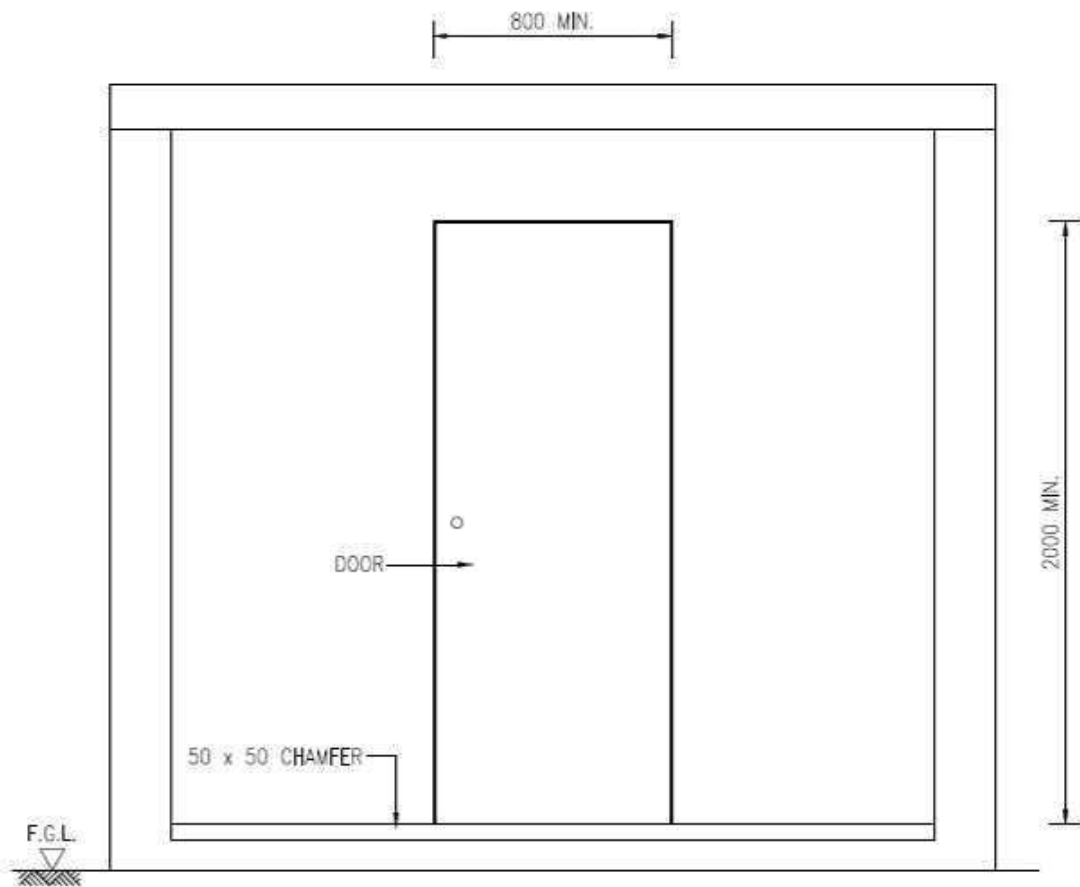

FRONT ELEVATION OF MASTER METER ROOM

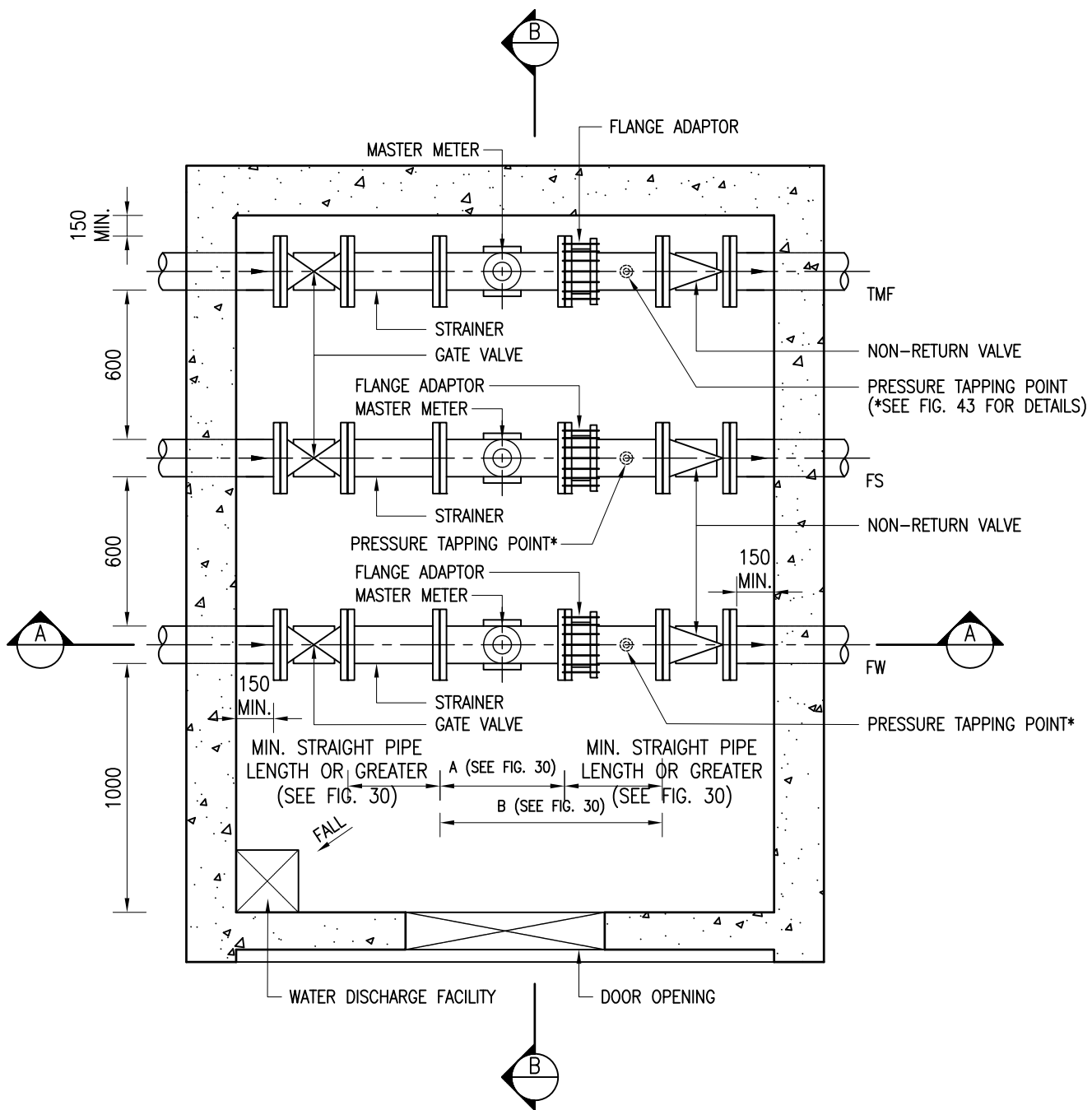

SECTIONAL PLAN OF MASTER METER ROOM

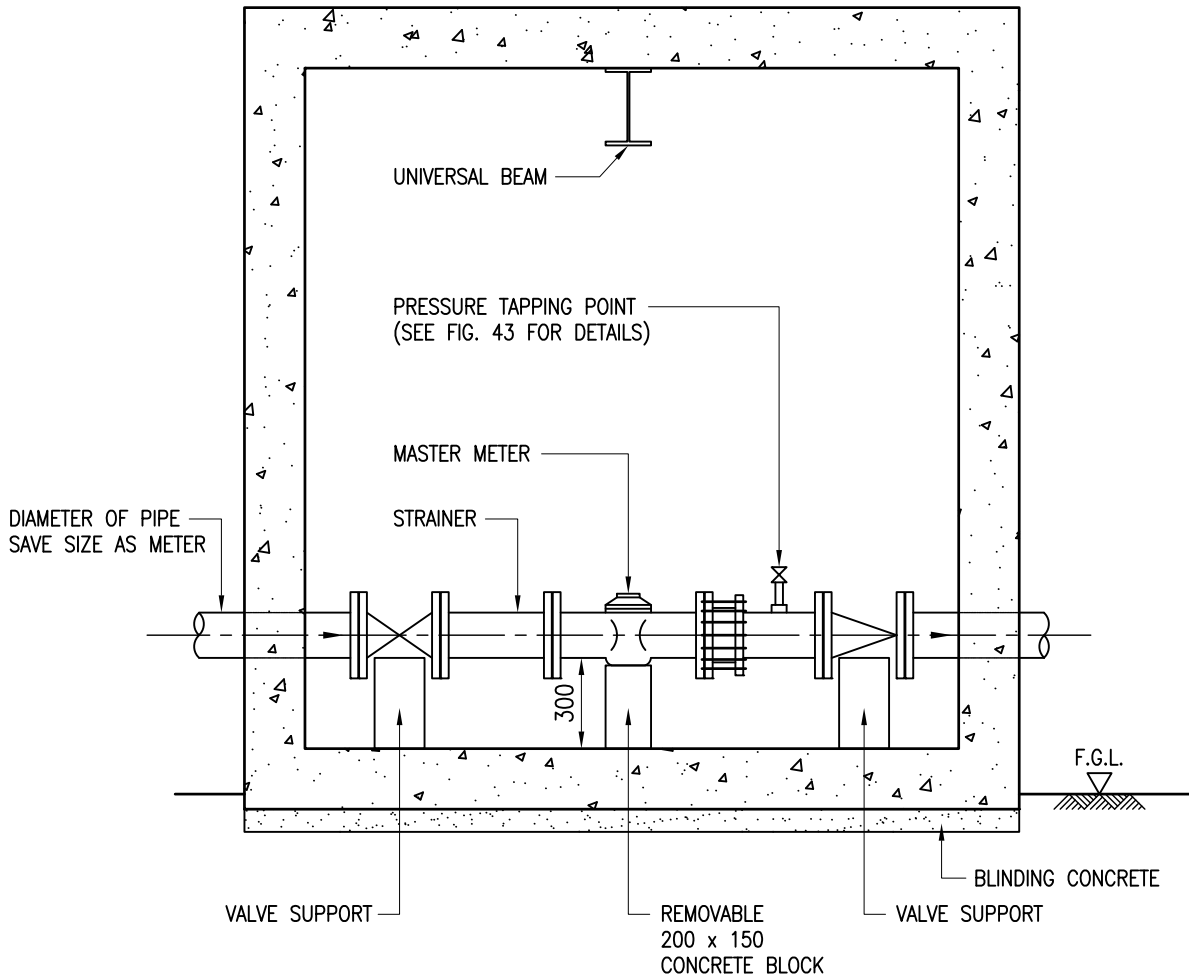

SECTION A - A OF MASTER METER ROOM

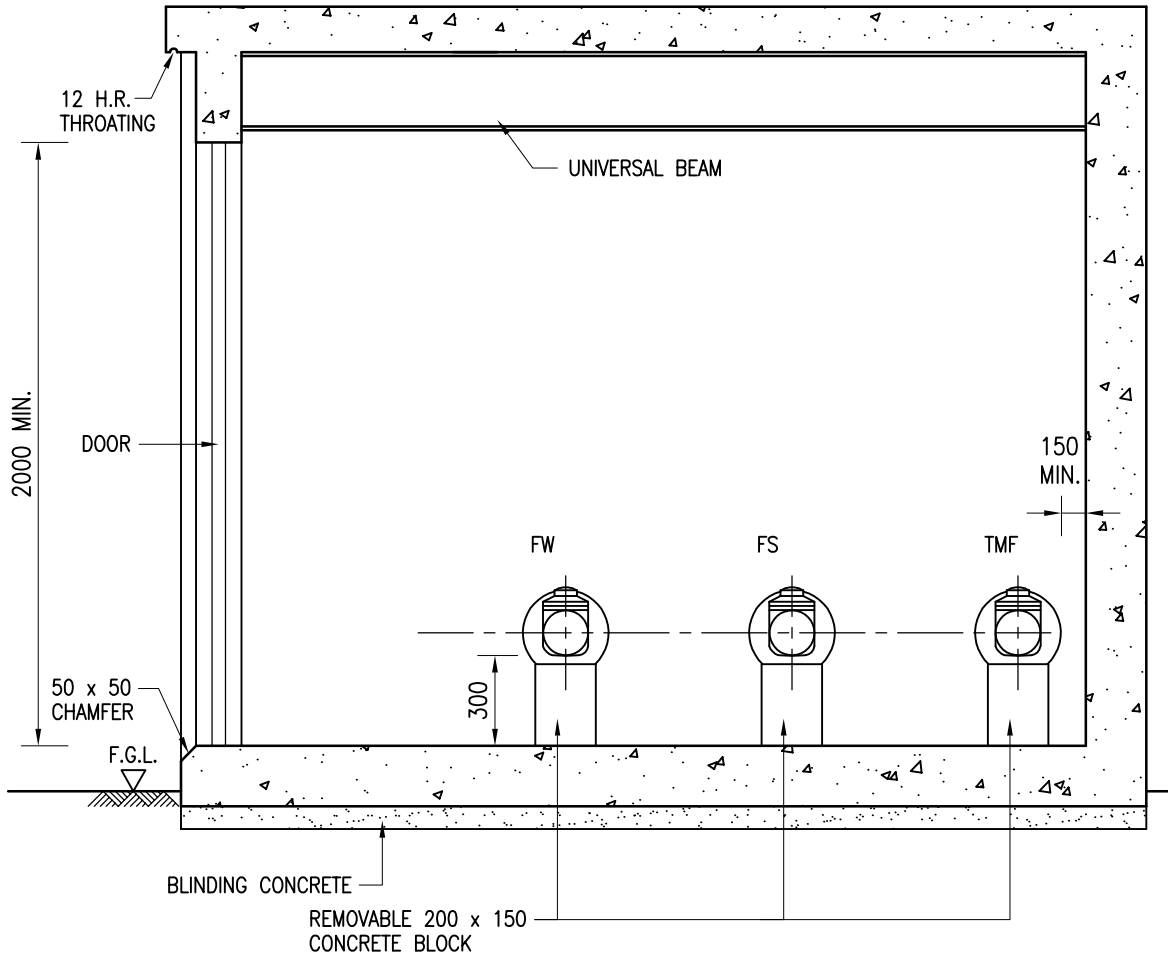

SECTION B - B OF MASTER METER ROOM

MASTER METER OF VARIOUS SIZES

METER TYPE	SIZE (mm)	DIMENSIONS (mm)		STRAIGHT PIPE LENGTH REQUIREMENT (mm)	
		A	B (Minimum)	UPSTREAM	DOWNSTREAM
SINGLE JET	50	300	450	5D	2D
	80	350	720		
	100	350	730		
TURBINE / WOLTMANN	50	310	450	5D	2D
	80	413	720		
	100	483	730		
	150	500	900		
	200	520	980		
	250	450	900		
	300	500	1000		
ULTRASONIC	50	200	450	3D	2D
ELECTROMAGNETIC	50	200	450	3D	2D
	80	200	720		
	100	250	730		
	150	300	1000		
	200	350	1000		
	250	400	1000		
	300	500	1000		

WEIGHT OF MASTER METER

SIZE IN mm (DN)	WEIGHT (kg)
50	12 - 40
80	15 - 50
100	20 - 60
150	40 - 100
200	60 - 140
250	70 - 180
300	90 - 260

NOTES :

1. ALL DIMENSIONS ARE IN MILLIMETERS.
2. THIS SET OF DRAWINGS SHALL BE READ IN CONJUNCTION WITH THE TECHNICAL REQUIREMENT FOR PLUMBING WORKS IN BUILDINGS IN PARTICULAR. THE REQUIREMENT RELATED TO INSTALLATION OF METER AS SPECIFIED IN CHAPTER 3 OF THIS TR.
3. UNIVERSAL BEAR(S) SHALL BE ABLE TO LIFT UP 2.5 TIMES THE WEIGHT OF THE METER AS ADVISED BY WATER AUTHORITY.
4. THE CENTRE-LINE OF THE PIPEWORK MUST BE HORIZONTAL.
5. ALL NEWLY LAID WATER MAINS MUST BE CLEANED AND STERILIZED BEFORE THE INSTALLATION OF SPECIFIED METER OR PRODUCT HAVING EQUIVALENT FUNCTIONS OF PERFORMANCE INSIDE THE ROOM.
6. DRAIN PIPE FOR METER ROOM SHALL BE PROVIDED.
7. THE TABLE SHALL BE READ IN CONJUNCTION WITH FIG. 27.
8. WHERE TMF SUPPLY IS GIVEN, A COMMUNAL TMF METER SHALL BE PROVIDED TO EACH INDIVIDUAL BLOCK OF BUILDING.
9. MASTER METERS FOR SIZE OF FRESH WATER SUPPLY MAIN NOT EXCEEDING 100mm IN DIAMETER COULD BE HOUSED IN A BOX OR CABINET INSTEAD OF IN A ROOM OR CHAMBER FIG. 31 SHALL BE REFERRED FOR DETAILS OF MASTER METER BOX AND CABINET.
10. THE WEIGH OF MASTER METER IS FOR REFERENCE ONLY AND THE WEIGH OF WATER IS NOT INCLUDED.

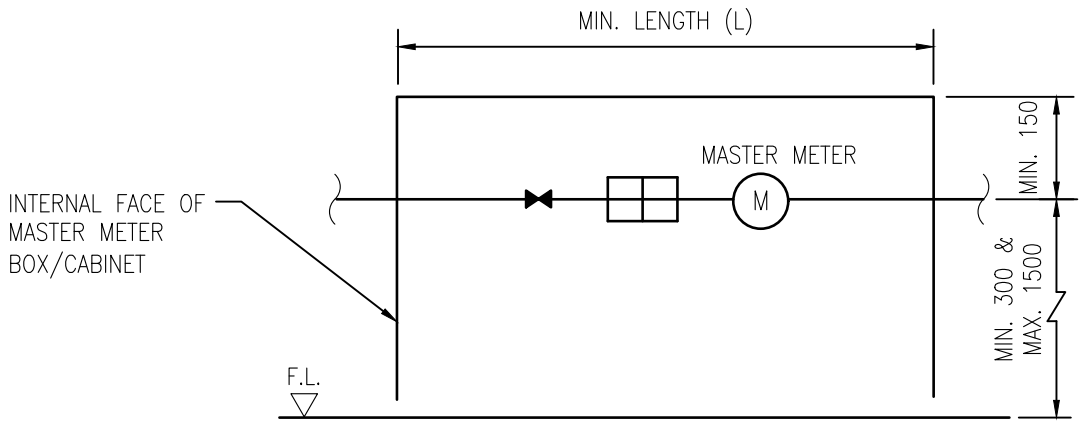

**ELEVATION FOR TYPICAL MASTER METER BOX/CABINET
FOR PIPE DIAMETER 40mm OR BELOW**



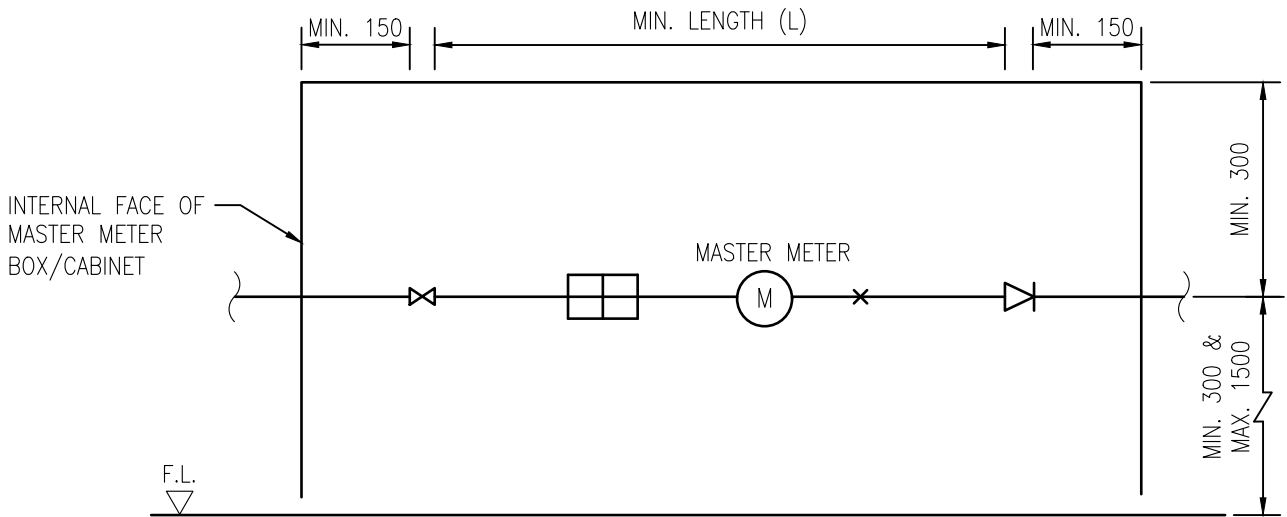

PIPE DIAMETER (mm)	MIN LENGTH (L) (mm)
15	700
25	800
40	900



**ELEVATION FOR TYPICAL MASTER METER BOX/CABINET
FOR PIPE DIAMETER 50mm TO 100mm**

PIPE DIAMETER (mm)	MIN LENGTH (L) BETWEEN GATE VALVE AND NON-RETURN VALVE (mm)
50	700
80	1120
100	1230

LEGENDS

-  LOOSE JUMPER TYPE STOPCOCK
-  GATE VALVE
-  NON-RETURN VALVE
-  STRAINER (A STRAINER SHALL BE INSTALLED UP STREAM OF ALL MASTER METER)
-  PRESSURE TAPPING POINT (SEE FIG. 43 FOR DETAILS)

NOTE

PROVISION OF ADEQUATE DRAINAGE INSIDE THE MASTER METER BOX/CABINET POSITIONED AT FLOOR LEVEL SHOULD BE MADE.

DETAILS OF MASTER METER BOX AND CABINET

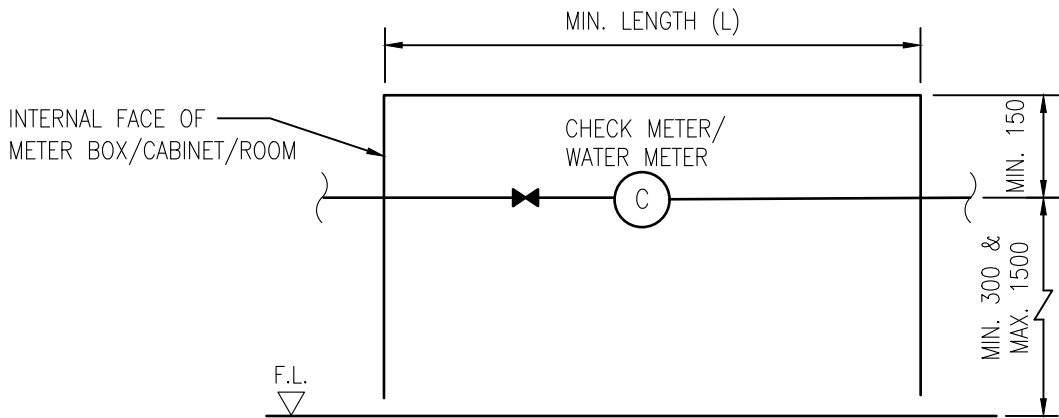

**ELEVATION FOR TYPICAL METER BOX/CABINET/ROOM
FOR PIPE DIAMETER 40mm OR BELOW**



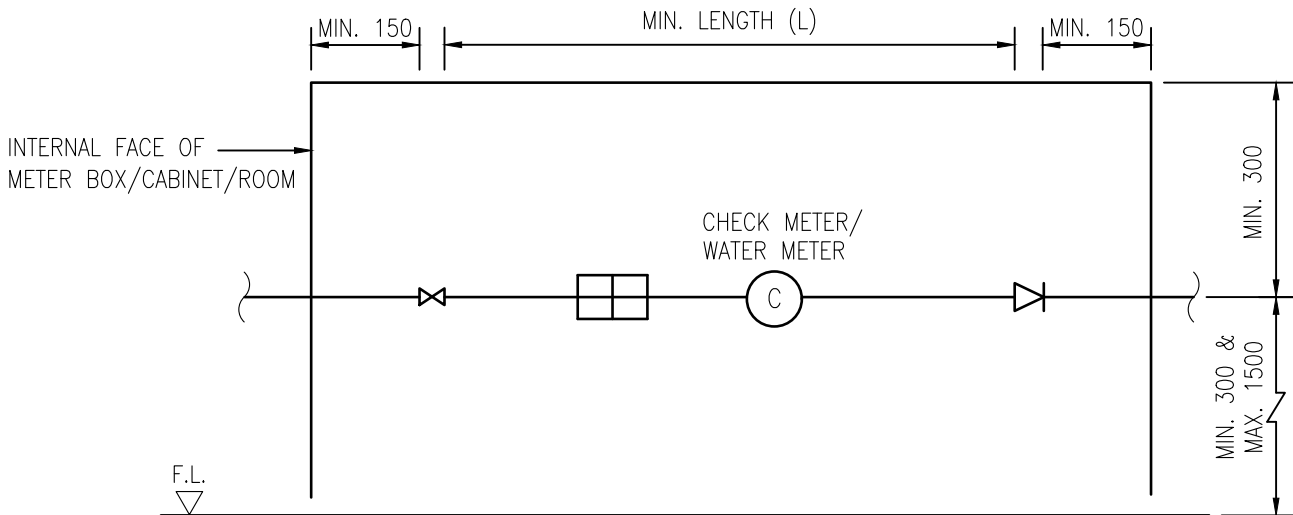

PIPE DIAMETER (mm)	MIN LENGTH (L) (mm)
15	700
25	800
40	900



**ELEVATION FOR TYPICAL METER BOX/CABINET/ROOM
FOR PIPE DIAMETER 50mm TO 150mm**

PIPE DIAMETER (mm)	MIN LENGTH (L) BETWEEN GATE VALVE AND NON-RETURN VALVE (mm)
50	700
80	1120
100	1230
150	1650

LEGENDS

-  LOOSE JUMPER TYPE STOPCOCK
-  GATE VALVE
-  NON-RETURN VALVE
-  STRAINER
(FOR SINGLE JET/TURBINE METER INSTALLED IN DIRECT SUPPLY SYSTEM, A STRAINER SHALL BE INSTALLED UPSTREAM OF METER)

NOTE

PROVISION OF ADEQUATE DRAINAGE INSIDE METER BOX/CABINET/ROOM POSITIONED AT FLOOR LEVEL SHOULD BE MADE.

**DETAILS OF METER BOX/CABINET/ROOM FOR
CHECK METER, WATER METER & SUB-METER**

Typical Schematic Plumbing Diagram for Kitchen Equipment for Non-domestic Use

~~Food Business (Restaurant) / Kitchen~~

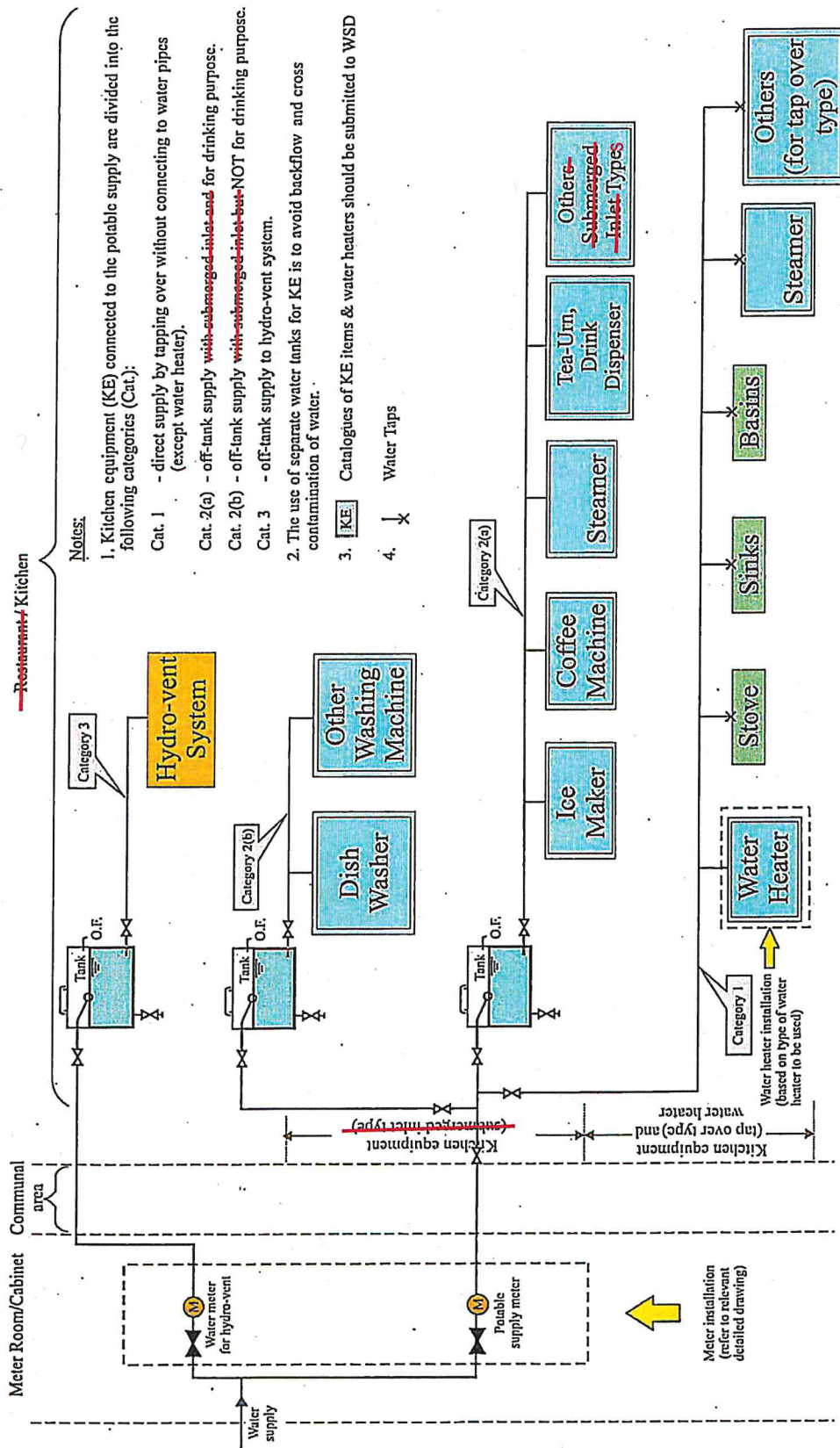

FIG. 34.

**更換水錶工程
暫停食水／臨時沖廁淡水*供應通告**

Meter Replacement Works

TEMPORARY SUSPENSION OF

FRESH WATER SUPPLY / TEMPORARY MAINS WATER FOR FLUSHING

受影響 地區 / 樓宇 AFFECTED AREAS / BUILDINGS :

日期 : DATE :	時間 : TIME :	至 To	日期 : DATE :	時間 : TIME :
-----------------------	-----------------------	----------------	-----------------------	-----------------------

水務署將於上述期間暫停供應食水／臨時沖廁淡水*予上述地區／樓宇，以便進行更換水錶工程。因暫停供水而引致不便之處，謹此致歉。

本署將可能提前恢復供水或因緊急情況而取消是次暫停供水，而恕不另行通告。如有任何查詢，請致電_____與本署職員_____或致電 **2824 5000** 與本署客戶電話諮詢中心聯絡。

In order to allow meter replacement work to be carried out, the fresh water supply/temporary mains water for flushing to the above areas/buildings will be temporarily suspended on the above-mentioned date and time. We apologize for any inconvenience caused.

Please note that without further notice the supply may be restored earlier than scheduled or the suspension of supply may have to be cancelled in case of unforeseen circumstances or emergencies.

Please call our staff _____ at Tel. No. _____ or our Customer Telephone Enquiry Centre at Tel. No. **2824 5000** if you require further information.

for Water Authority : (_____)

水務監督 : (_____ 代行)



水務署
香港灣仔告士打道七號入境事務大樓
Water Supplies Department
Immigration Tower, 7 Gloucester Road, Wanchai, Hong Kong.
Web Site 萬維網址 : <http://www.info.gov.hk/wsd/>
E-Mail 電子郵件 : wsdinfo@wsd.gov.hk

日期 : _____
Date : _____

把不適用 刪去 Delete as appropriate

NOTE: WHEN REPLACEMENT OF MASTER METER FOR FIRE SERVICE IS REQUIRED, A COPY OF ABOVE SUSPENSION NOTICE SHOULD BE SENT TO FIRE SERVICE COMMUNICATION CENTRE OF FIRE SERVICES DEPARTMENT (FAX NO.: 2311 0066).

SUSPENSION NOTICE OF FRESH WATER SUPPLY/
TEMPORARY MAINS WATER FOR FLUSHING

FIG. 35

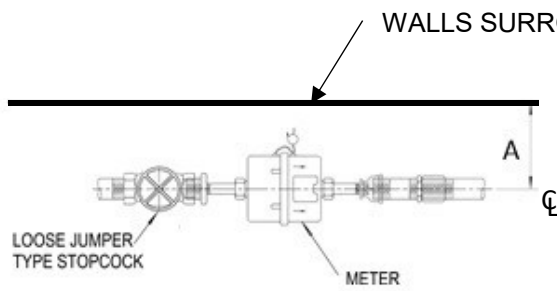

SMALL SIZED METERS (15MM – 40MM)
(Fig. 36-1)

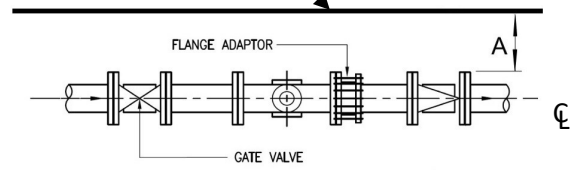

LARGE SIZED METERS (50 AND ABOVE)
(Fig. 36-2)

SECTIONAL PLANS SHOWING MINIMUM CLEARANCE FROM WALL FOR WATER METER AND CHECK METER POSITIONS

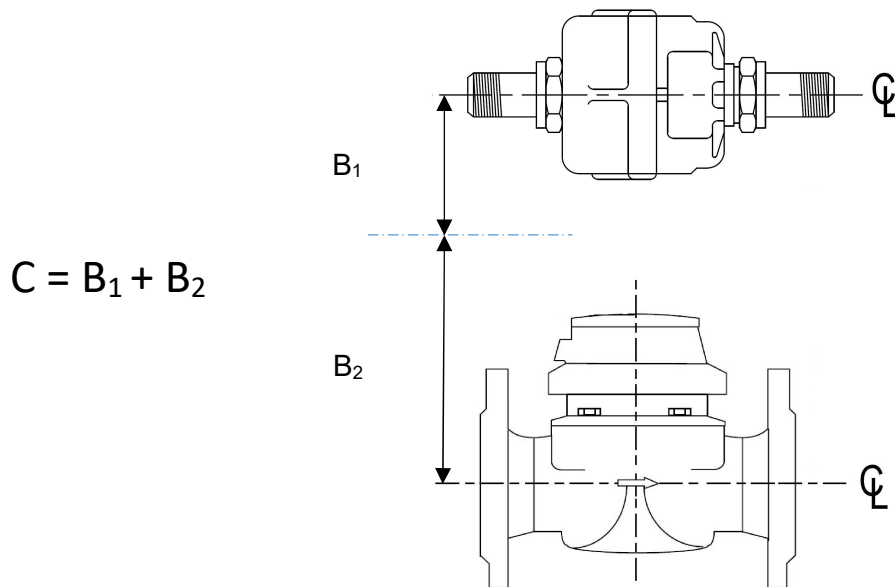

MINIMUM DISTANCE OF WATER METER FROM OTHER METERS
(Fig. 36-3)

Nominal Size of water meters (mm)	Min. Distance of water meter and the surrounding wall (mm) [A]	Min. Distance of a meter from other meters (mm) [C]	Corresponding Dimension [B1 or B2]
15	100	(Measure from center line of water meter to surrounding wall, see Fig. 36-1)	B ₁ +B ₂ (B ₁ & B ₂ represent the corresponding dimension of the meters, see Fig. 36-3)
25	100		100
40	125		125
50	150 (Measure from flange edge of water meter to surrounding wall, see Fig. 36-2)	(Measure from center line of water meter to surrounding wall, see Fig. 36-1)	B ₁ +B ₂ or 400mm whichever is less
80~100			250
150			300
200			B ₁ +B ₂ or 500mm whichever is less
250			320
300			B ₁ +B ₂ or 600mm whichever is less
			370
			400

MINIMUM CLEARANCE OF WATER METERS

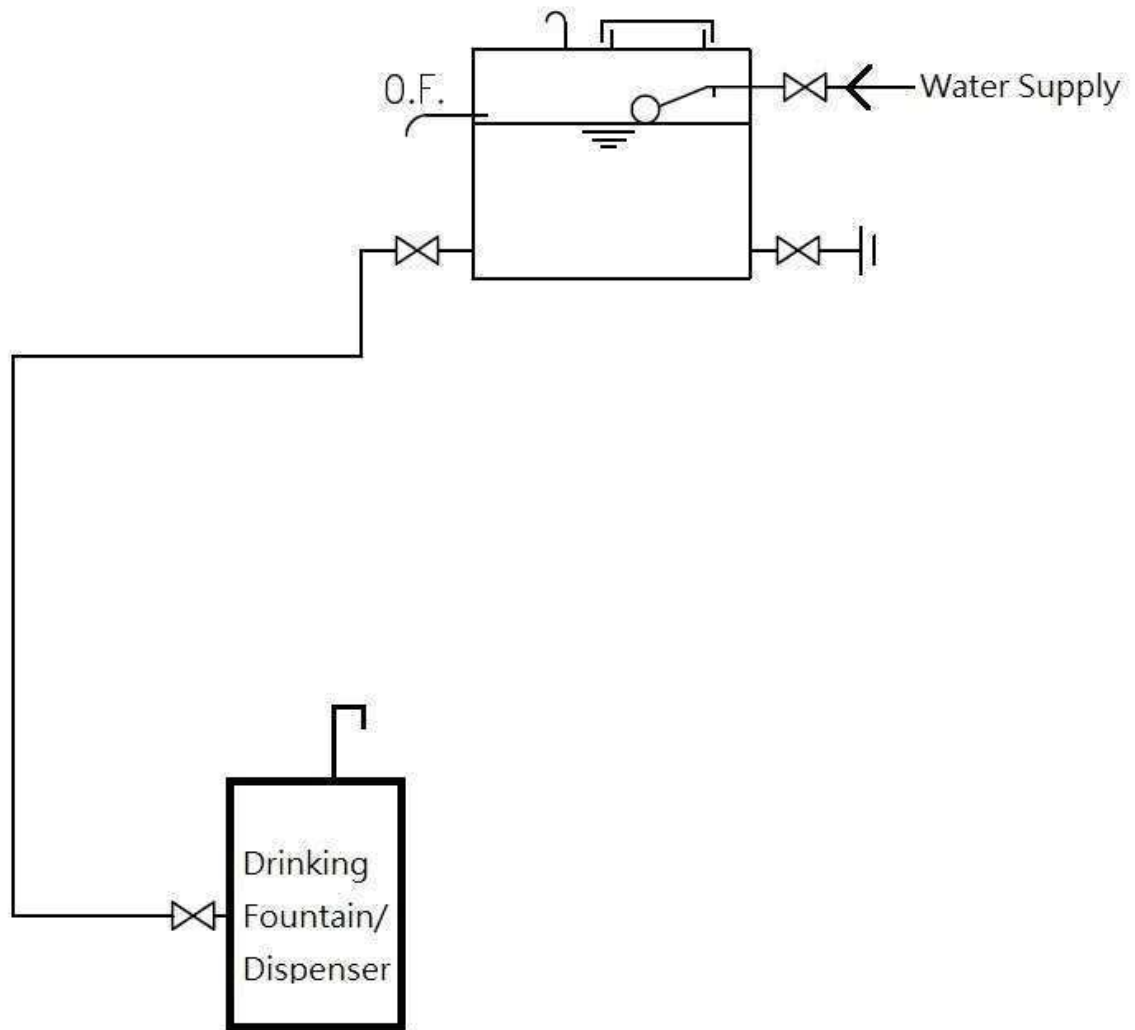

EXAMPLE OF WATER DISPENSER/DRINKING FOUNTAIN -
(NOT LOCATED AT STREET SIDE) -
SUPPLIED BY A WATER TANK WITHOUT OTHER DRAW-OFF POINT -

FIG. 37 -

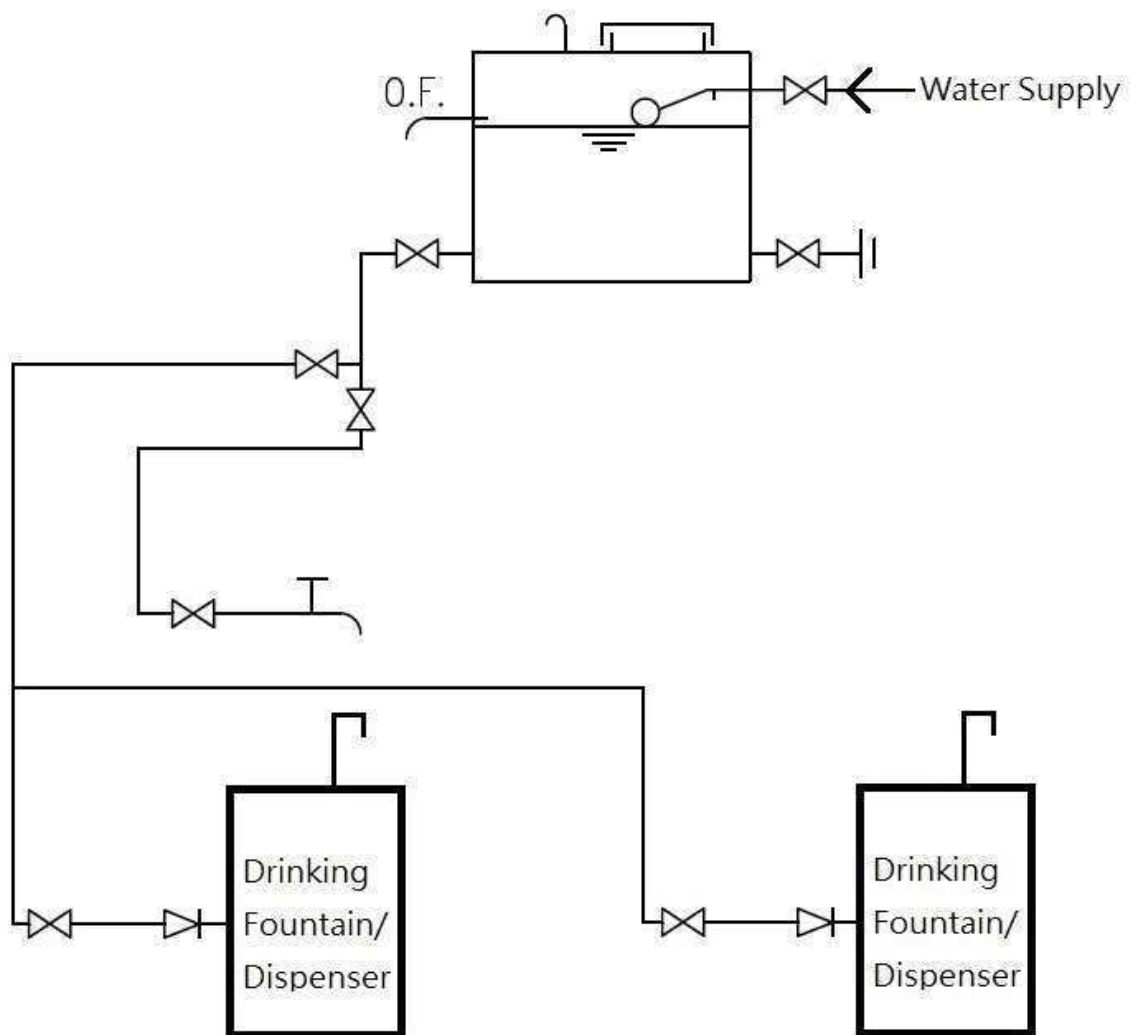

EXAMPLE OF WATER DISPENSER/DRINKING FOUNTAIN -
(NOT LOCATED AT STREET SIDE) -
SUPPLIED BY A WATER TANK WITH OTHER DRAW-OFF POINT -

FIG. 38 -

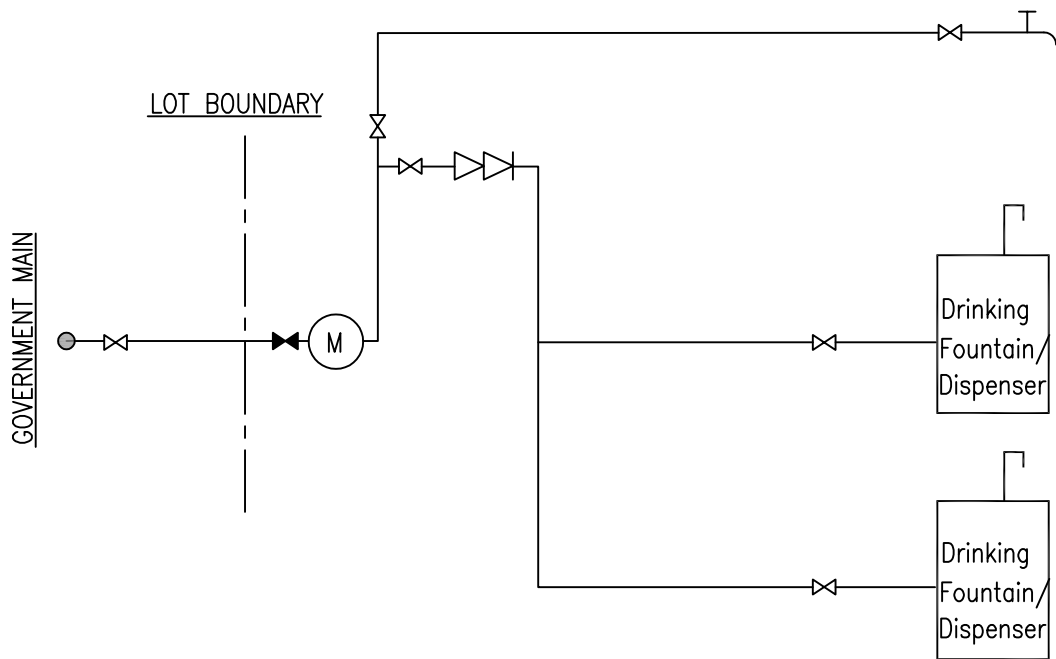

EXAMPLE OF WATER DISPENSER/ DRINKING FOUNTAIN
(NOT LOCATED AT STREET SIDE)
IN DIRECT SUPPLY SYSTEM (USE OF DOUBLE CHECK VALVE)

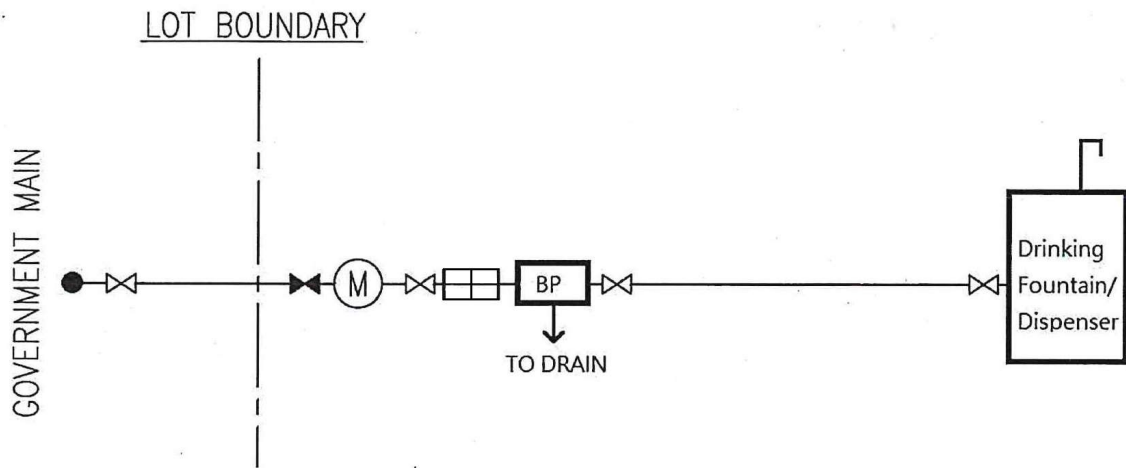

A) SINGLE DRINKING FOUNTAIN/DISPENSER -

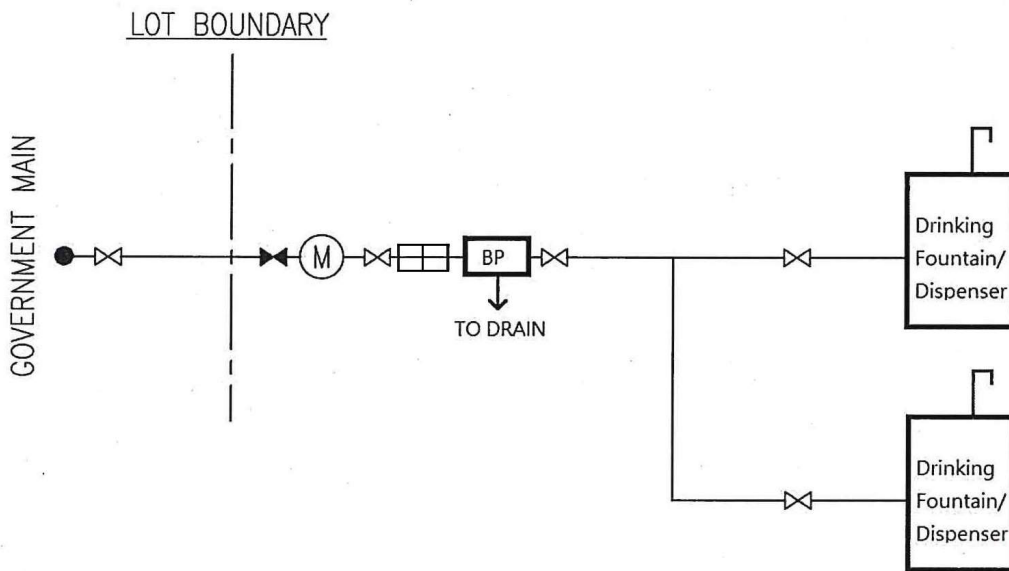

B) MORE THAN ONE DRINKING FOUNTAIN/DISPENSER

EXAMPLE OF WATER DISPENSER /DRINKING FOUNTAIN -
(LOCATED AT STREET SIDE) -
DIRECTLY CONNECTED TO THE MAINS -
(USE OF BACKFLOW PREVENTOR) -

FIG. 40 -

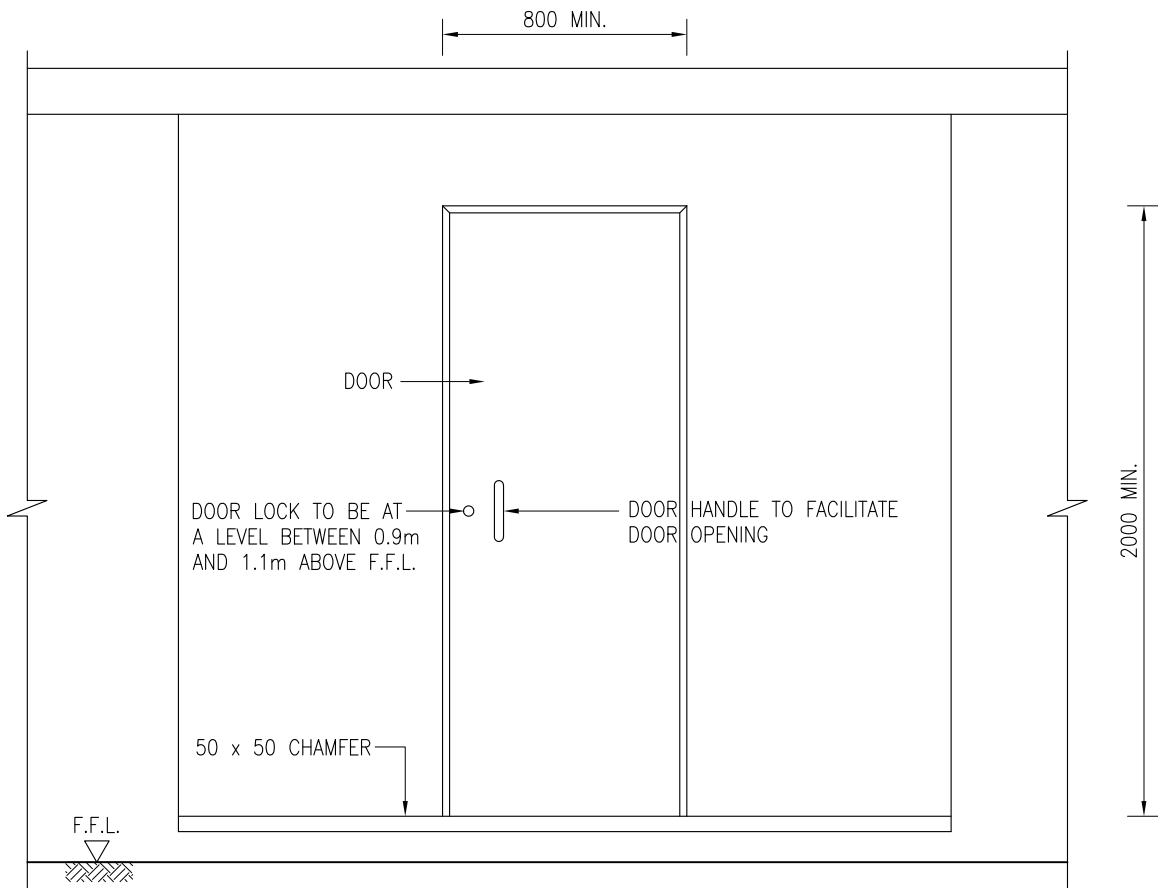

ELEVATION

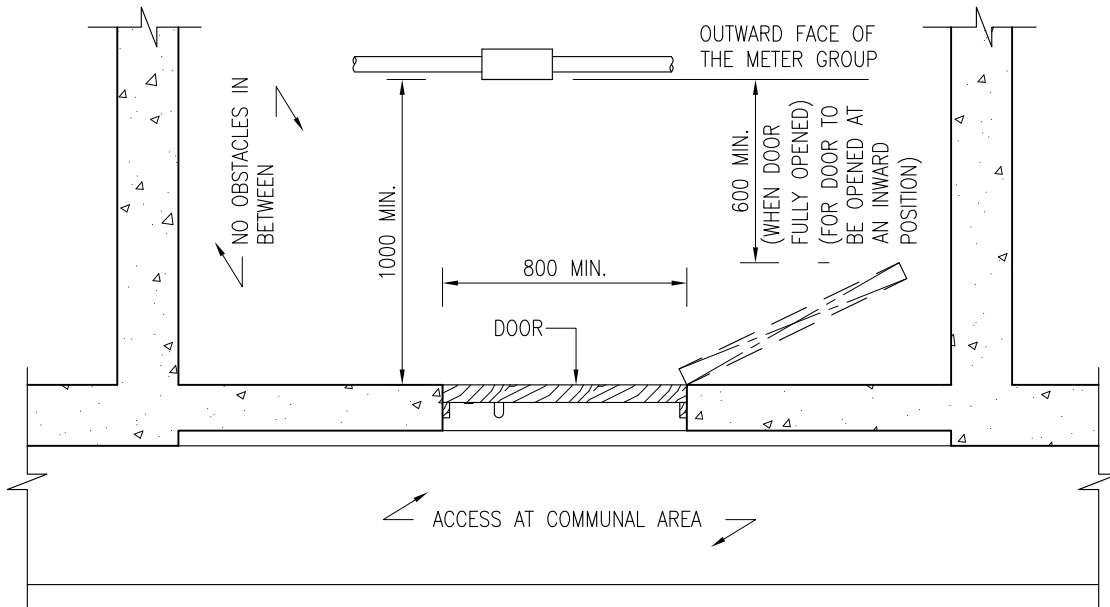

SECTIONAL PLAN

DOOR TO METER ROOM

NOTE : DOOR TO THE METER ROOM SHOULD NOT BE EQUIPPED WITH ANY SELF-CLOSING DEVICE

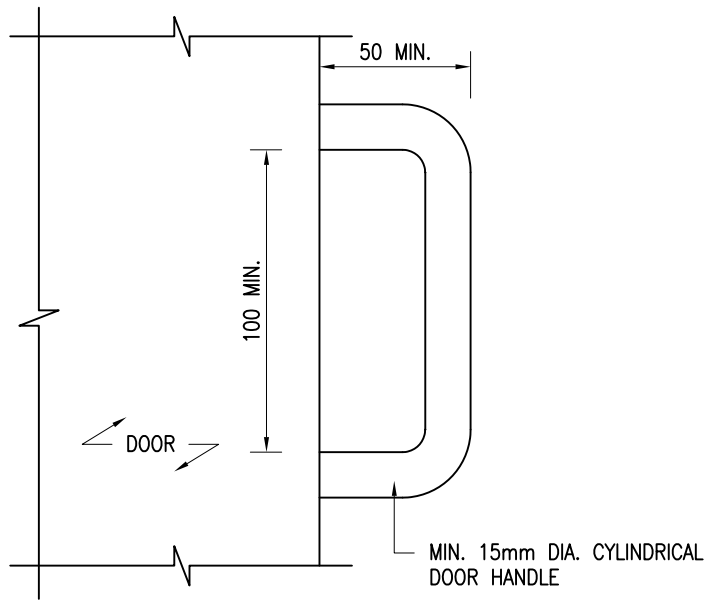

OPTION 1

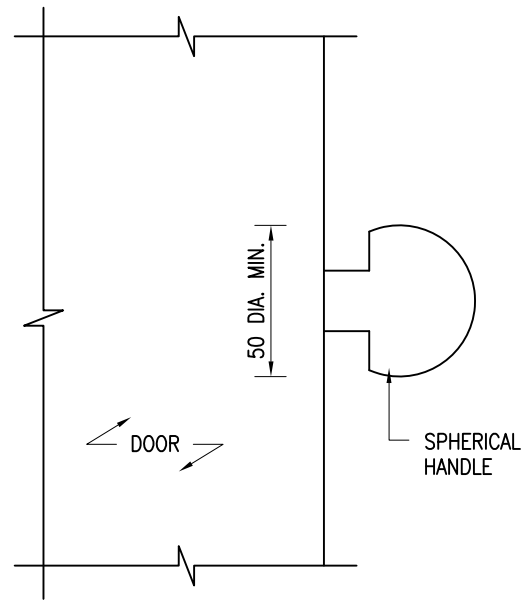

OPTION 2

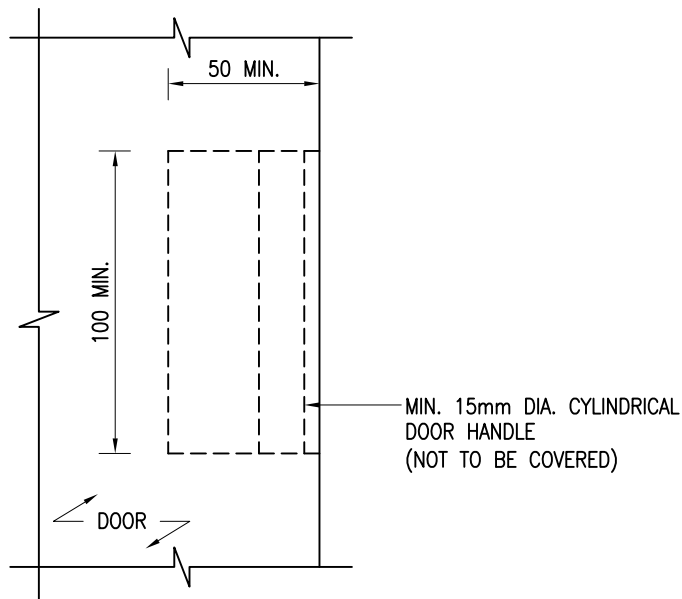

OPTION 3

TYPES OF DOOR HANDLE TO BE ADOPTED

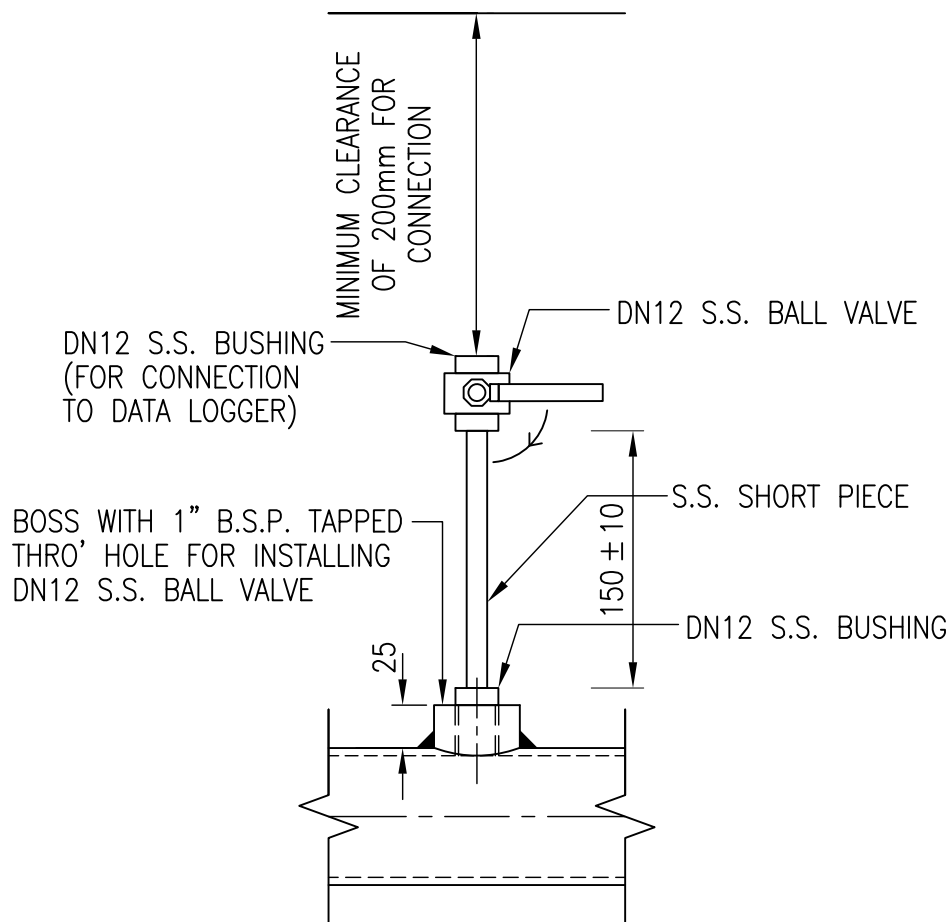

DETAILS OF PRESSURE TAPPING POINT

NOTES :

1. ALL DIMENSIONS ARE IN MILLIMETRES EXCEPT OTHERWISE STATED.
2. ALL WELDS ARE MARKED THUS  .

FIG. 43

Schematic Piping Diagram For Improved Hose Reel System (Direct-feed type)

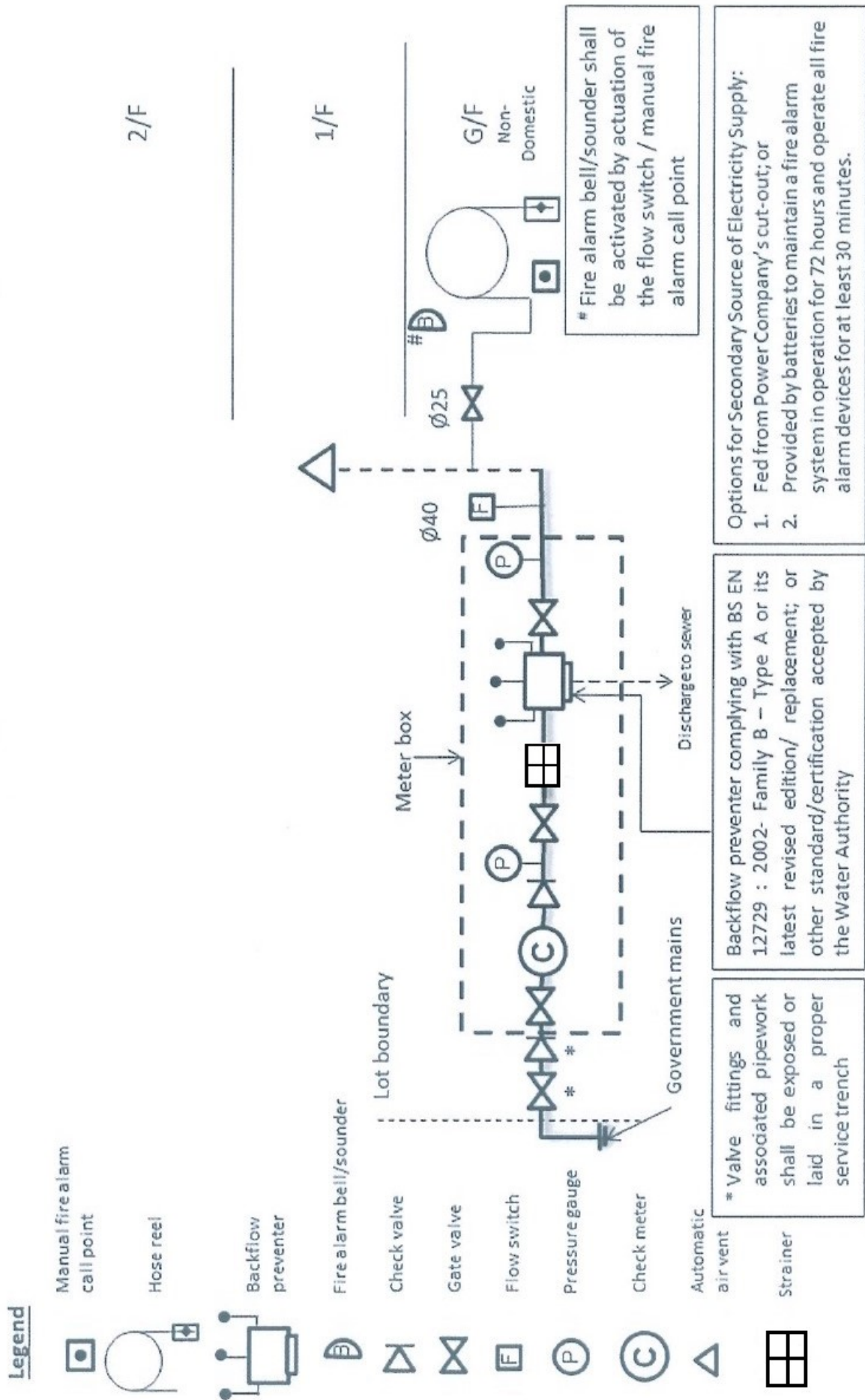

Fig. 44